International Standard



4696

INTERNATIONAL ORGANIZATION FOR STANDARDIZATION • МЕЖДУНАРОДНАЯ ОРГАНИЗАЦИЯ ПО СТАНДАРТИЗАЦИИ • ORGANISATION INTERNATIONALE DE NORMALISATION

Iron ores — Low-temperature disintegration test — Method using cold tumbling after static reduction

Minerais de fer — Essai de désagrégation à basse température — Méthode au tambour à froid après réduction statique

First edition — 1984-03-01

ITeH STANDARD PREVIEW
(standards.iteh.ai)

[ISO 4696:1984](https://standards.iteh.ai/catalog/standards/sist/debc5317-67c6-47b9-83db-2a2285f91253/iso-4696-1984)

<https://standards.iteh.ai/catalog/standards/sist/debc5317-67c6-47b9-83db-2a2285f91253/iso-4696-1984>

UDC 553.31 : 542.4

Ref. No. ISO 4696-1984 (E)

Descriptors : iron ores, tests, testing conditions, low temperature tests, reduction analysis, tumbling, disintegration tests.

Price based on 6 pages

Foreword

ISO (the International Organization for Standardization) is a worldwide federation of national standards bodies (ISO member bodies). The work of developing International Standards is carried out through ISO technical committees. Every member body interested in a subject for which a technical committee has been authorized has the right to be represented on that committee. International organizations, governmental and non-governmental, in liaison with ISO, also take part in the work.

Draft International Standards adopted by the technical committees are circulated to the member bodies for approval before their acceptance as International Standards by the ISO Council.

International Standard ISO 4696 was developed by Technical Committee ISO/TC 102, *Iron ores*, and was circulated to the member bodies in November 1982.

ITeH STANDARD PREVIEW
(standards.iteh.ai)

It has been approved by the member bodies of the following countries:

ISO 4696:1984

Australia	India	South Africa, Rep. of
Canada	Italy	Sweden
China	Japan	United Kingdom
Czechoslovakia	Korea, Dem. P. Rep. of	USA
Egypt, Arab Rep. of	Poland	USSR
France	Portugal	Venezuela
Germany, F.R.	Romania	

No member body expressed disapproval of the document.

Iron ores — Low-temperature disintegration test — Method using cold tumbling after static reduction

0 Introduction

This International Standard describes a test method for evaluating the disintegration behaviour of iron ores reduced in a fixed bed under specific conditions relevant to the low temperature zone in the blast furnace for iron making. This method is a measure of the breakdown of blast furnace burden materials under conditions resembling those in the upper part of the blast furnace shaft.

The results of this test should be considered in conjunction with the results of other reduction tests,¹⁾ particularly those conducted at high temperatures.

1 Scope and field of application

This International Standard specifies a method for testing the disintegration of iron ores by tumbling, at room temperature, a sample that has been reduced in a fixed bed at a temperature of 500 °C.

This method is applicable to natural coarse iron ores and to iron ore agglomerates such as pellets or sinters.

2 References

- ISO 3081, *Iron ores — Increment sampling — Manual method.*
ISO 3083, *Iron ores — Preparation of samples — Manual method.*

3 Principle

Static reduction of the test portion at a specified size range at a temperature of 500 °C using reducing gas consisting of CO, CO₂ and N₂.

Cooling of the test portion, after 1 h reduction time, to a temperature below 100 °C, and tumbling by using a small tumbler drum for 300 revolutions in total. Sieving with test sieves having square mesh apertures of 6,30 mm, 3,15 mm, and 500 μm.

Calculation of reduction-disintegration indices (RDI), as a quantitative measure of the degree of disintegration of iron ores that have been reduced and then tumbled: the percentage mass of material greater than 6,30 mm, greater than 3,15 mm, and less than 500 μm respectively are related to the total mass of test portion after reduction and before tumbling.

4 Test conditions

Gas volumes and flow rates used in this International Standard are as measured at a temperature of 0 °C and at atmospheric pressure (101,325 kPa).²⁾

4.1 Composition of reducing gas

The reducing gas shall consist of:

CO	20 ± 0,5 % (V/V);
CO ₂	20 ± 0,5 % (V/V);
N ₂	60 ± 0,5 % (V/V).

Impurities in the reducing gas shall not exceed

H ₂	0,02 % (V/V);
O ₂	0,1 % (V/V);
H ₂ O	0,2 % (V/V).

NOTE — If the above reducing gas cannot be achieved, the alternative gas composition given below may be used:

CO	20 ± 0,5 % (V/V);
CO ₂	20 ± 0,5 % (V/V);
H ₂	2,0 ± 0,5 % (V/V);
N ₂	58 ± 0,5 % (V/V).

Significantly different reduction disintegration indices, however, can be obtained when the reducing gas contains 2 % hydrogen rather than less than 0,02 % hydrogen.

4.2 Flow rate of reducing gas

The reducing gas flow rate shall, during the test period, be maintained at 20 ± 1 l/min.

1) International Standards dealing with the reducibility, the relative reducibility and the relative free-swelling index of iron ores are in preparation.

2) 1 mm Hg ≈ 0,133 3 kPa, 1 atm = 0,101 325 MPa.

4.3 Temperature of test

The reducing gas shall be preheated before entering the test portion to maintain the test portion at 500 ± 10 °C during the entire test period.

5 Apparatus

The apparatus shall consist of the following:

- a) a system to supply and regulate the gases;
- b) a reduction tube;
- c) an electrically heated furnace to heat the sample to the specified temperature;
- d) a tumbler drum;
- e) test sieves;
- f) a weighing device;

Figure 1 shows an example of the arrangement of the reduction tube and furnace.

5.1 Reduction tube, made of non-scaling, heat-resisting metal to withstand a temperature of greater than 600 °C. The diameter of the sample bed shall be 75 ± 1 mm.

The test portion may be placed on a perforated plate or, if desired, on alumina balls on the perforated plate, in order to ensure a uniform gas flow through the test portion.

Figure 2 shows an example of the reduction tube.

5.2 Furnace, having a heating capacity sufficient to maintain the entire test portion and the gas entering the bed at 500 °C, and being equipped with a heating element suitable for the specified temperature.

5.3 Tumbler drum, consisting of a vessel having an internal diameter of 130 mm and an inside length of 200 mm.

Two equally spaced steel lifters 200 mm long 20 mm wide and 2 mm thick shall be mounted longitudinally inside the drum. These may be mounted on a frame that can be inserted inside the vessel from one end.

One end of the vessel shall be closed and the other open. A close fitting lid shall be held in place on the opening to ensure a dust-tight seal.

Figure 3 shows an example of the tumbler drum.

5.4 Test sieves, having square mesh apertures of the following nominal sizes:

16,0 mm - 12,5 mm - 10,0 mm - 6,30 mm - 3,15 mm and 500 µm.

5.5 Weighing device, of adequate load capacity and accurate to 0,1 g.

6 Preparation of test sample

In the case of a commercial test, the test sample shall be prepared according to ISO 3083 from the sample for physical testing which has been taken in accordance with ISO 3081. The test sample shall be oven-dried at 105 ± 5 °C for at least 2 h and cooled to room temperature before testing.

The total mass of the test sample shall be approximately 2 kg on a dry basis, being prepared as follows:

- a) Pellets

The test sample in the size range of 10,0 mm to 12,5 mm, or other sizes as agreed between the parties concerned, shall be obtained by sieving and, after sieving, only pellets taken at random, for example by riffing, shall be used for the test.

- b) Ore or sinter

The test sample in the size range of 10,0 mm to 12,5 mm shall be prepared as follows:

Screen the sample on a 12,5 mm sieve and carefully crush the plus 12,5 mm material until it all passes the 16,0 mm sieve. Combine all fractions and remove by sieving the plus 12,5 mm and the minus 10,0 mm material from the sample.

7 Procedure

7.1 Number of determinations

Carry out the test generally in duplicate on one ore sample.

7.2 Test portion

Weigh, to the nearest 0,1 g, approximately 500 g (± 1 particle) of the test sample. The test portion should be obtained from the test sample either by means of riffle divider or by manual increment division method.

7.3 Reduction

Place the test portion (7.2) in the reduction tube (5.1) so that the surface is even. Close the top of the reduction tube. Then insert the reduction tube into the furnace (5.2) and, if desired, attach it to the weighing device of appropriate capacity and accuracy (5.5), ensuring that there is no contact with the furnace or heating elements.

NOTE — The use of a weighing device for continuous monitoring is optional.

Replace the air in the tube with inert gas. Heat the test portion and while heating pass a flow of inert gas through the test portion at a flow rate of approximately 20 l/min. Continue the heating, while passing inert gas until the test portion reaches the test temperature of 500 ± 10 °C.

NOTE — Unless the characteristics of the furnace and thermocouple are very well known a period of about 15 min should be allowed for temperature equilibration at 500 °C.

CAUTION – Carbon monoxide and the reducing gas which contains carbon monoxide are toxic and therefore hazardous. The reduction shall be carried out in a well ventilated area or under a hood. Precautions, according to the safety codes of each country, shall be taken for the safety of the operator.

Introduce the reducing gas (4.1) at a flow rate of 20 ± 1 l/min to replace the inert gas and to reduce the test portion. Continue the reduction with the reducing gas for 1 h.

After 1 h reduction time, stop the flow of the reducing gas and cool the test portion to a temperature below $100\text{ }^{\circ}\text{C}$ in the reduction tube under a flow of inert gas.

7.4 Tumbling

Remove the test portion carefully from the reduction tube, determine the mass (mass m_0) and place it in the tumbler drum (5.3). Fasten the lid tightly and rotate the drum for a total of 300 revolutions at a rate of 30 ± 1 rev/min.

Remove all material from the drum, determine the mass, hand sieve with care on 6,30 mm, 3,15 mm and 500 μm sieves. Determine and record the mass of each fraction retained on 6,30 mm (mass m_1), 3,15 mm (mass m_2) and 500 μm (mass m_3). Material lost during tumbling and sieving shall be considered to be minus 500 μm .

NOTE – Equivalent mechanical sieving may be used provided that preliminary test results give similar results to hand sieving within the permissible tolerance of 2 % absolute.

8 Expression of results

The reduction-disintegration index, RDI, as a percentage by mass, is calculated from the following formulae:

$$\text{RDI}_{+6,3} = \frac{m_1}{m_0} \times 100$$

$$\text{RDI}_{+3,15} = \frac{m_1 + m_2}{m_0} \times 100$$

$$\text{RDI}_{-0,5} = \frac{m_0 - (m_1 + m_2 + m_3)}{m_0} \times 100$$

where

m_0 is the mass, in grams, of test portion after reduction and before tumbling;

m_1 is the mass, in grams, of oversize fraction retained on the 6,30 mm sieve;

m_2 is the mass, in grams, of oversize fraction retained on the 3,15 mm sieve;

m_3 is the mass, in grams, of oversize fraction retained on the 500 μm sieve;

Repeatability and number of tests are as given in the annex.

9 Test report

The test report shall include the following information:

- a) reference to this International Standard;
- b) results of the test: reduction-disintegration indices expressed to one decimal place;
- c) identification of the sample;
- d) reducing gas composition used;
- e) sieving conditions, e.g. method of sieving, and sieving time;
- f) total mass of material inserted into the tumbler drum and taken from the tumbler drum;
- g) any operation and any test conditions not specified in this International Standard or regarded as optional which may have had an influence on the results.

ITeH STANDARD PREVIEW
(standards.iteh.ai)
ISO 4696:1984
<https://standards.iteh.ai/catalog/standards/sist/debc5317-67c6-47b9-83db-2a2285f91253/iso-4696-1984>

Dimensions in millimetres

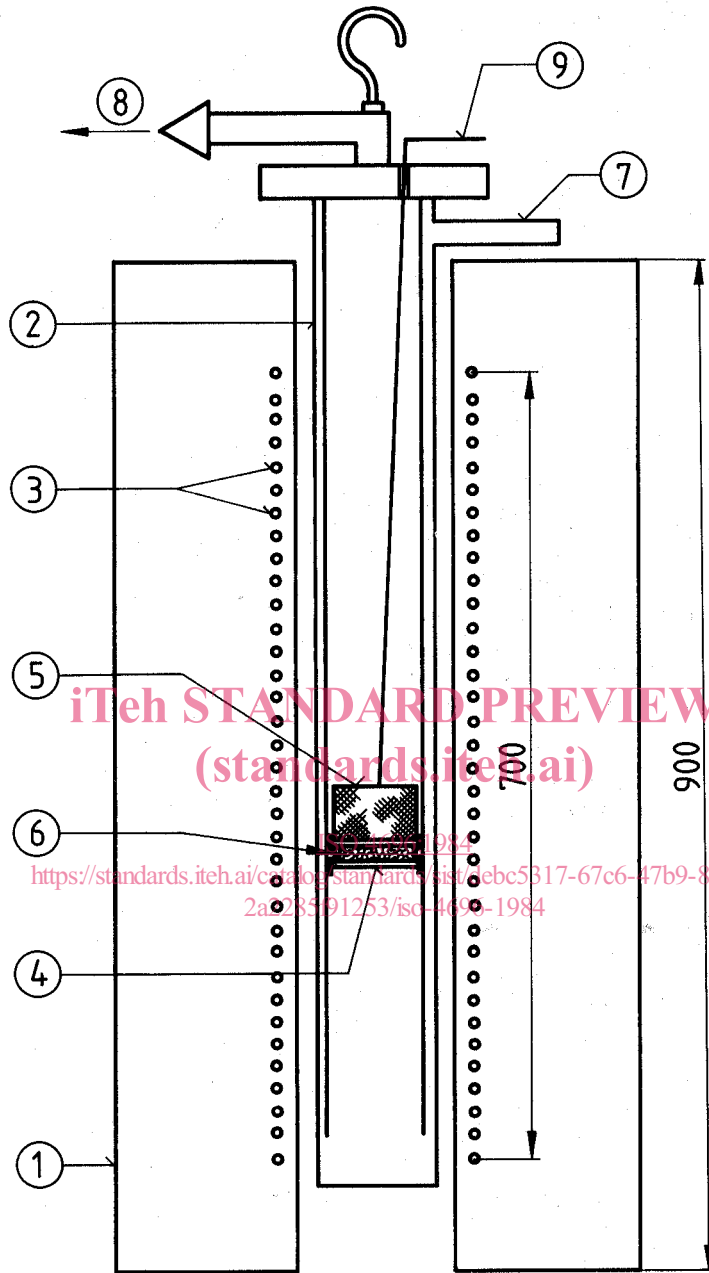

NOTE — Dimensions are shown for information only.

- | | | | |
|---|------------------|---|------------------------|
| ① | Furnace (10 kVA) | ⑥ | Layer of alumina balls |
| ② | Reduction tube | ⑦ | Gas inlet |
| ③ | Heating element | ⑧ | Gas outlet |
| ④ | Perforated plate | ⑨ | Thermocouple |
| ⑤ | Test portion | | |

Figure 1 — Example of test apparatus : arrangement of reduction tube (5.1) and furnace (5.2).

Dimensions in millimetres

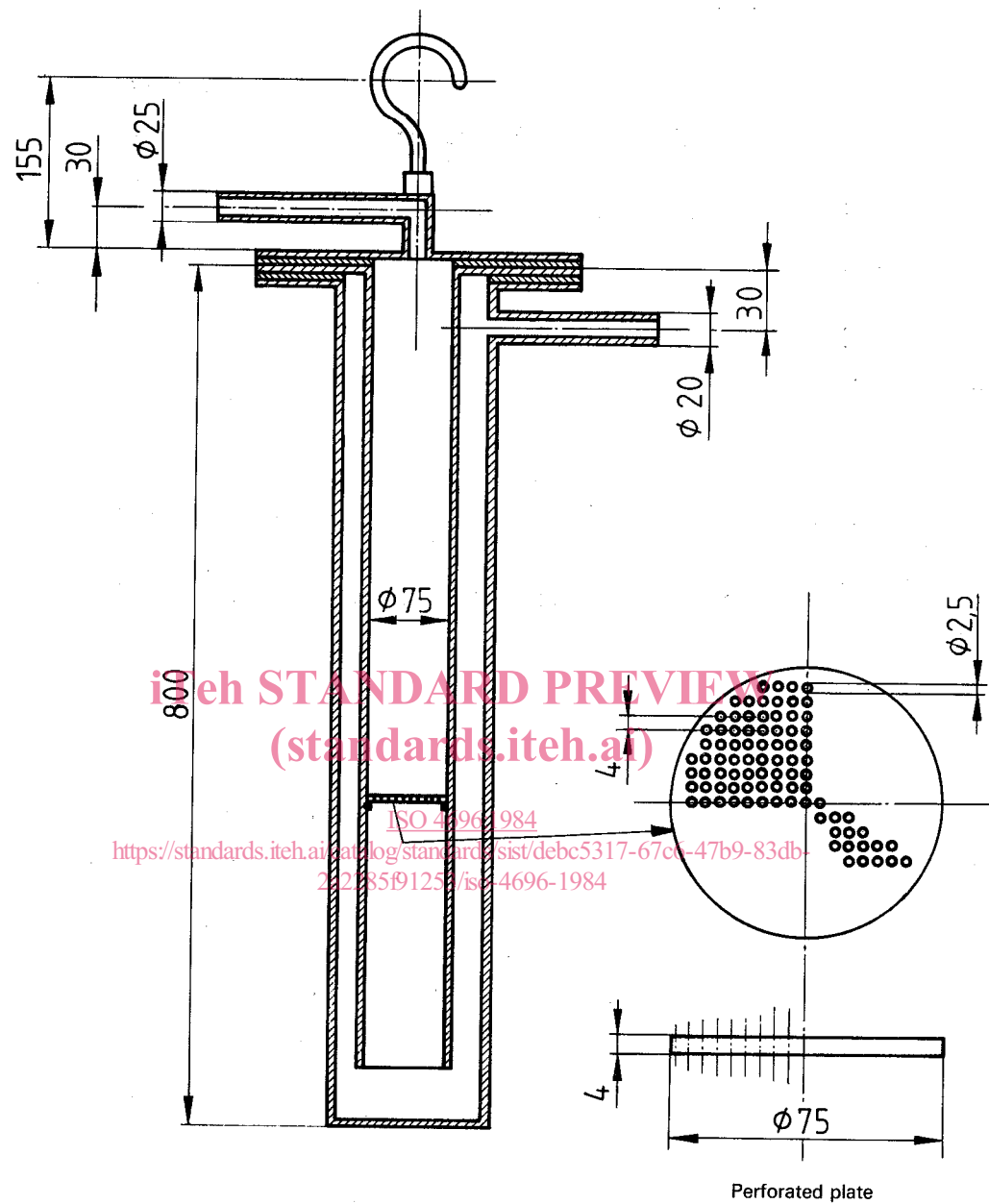

NOTE — Dimensions not specified in clause 5 are shown for information only.

- Hole diameter: 2,5 mm
- Pitch between holes: 4 mm
- Number of holes: 241
- Total hole area: 11,8 cm²
- Thickness of plate: 4 mm

Figure 2 — Example of reduction tube (5.1)

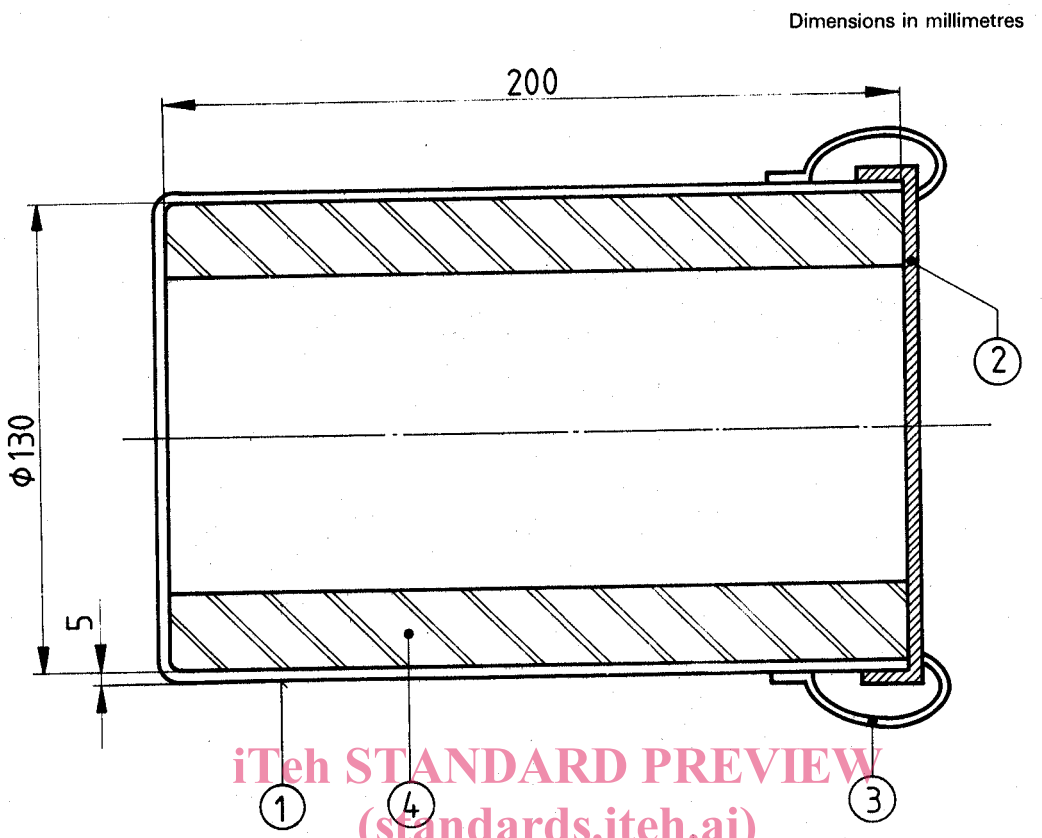

iTeh STANDARD PREVIEW
(standards.iteh.ai)

- | | | | | |
|---|--------|---|---|--|
| ① | Vessel | ISO 4696:1984 | ④ | Frame with lifters |
| ② | Lid | https://standards.iteh.ai/catalog/standards/sist/debc5317-67c6-47b9-83db-2a2285f91253/iso-4696-1984 | | Lifters: 20 mm wide
by 2 mm thick
Material: plain carbon steel |
| ③ | Clamps | | | |

Figure 3 – Example of tumbler drum (5.3)

Annex

Repeatability and number of tests

(Forms part of the Standard.)

For a paired result, the value of the range will decide if additional tests are required as indicated in the table below:

Mean value of index % (m/m)	Range ($X_1 - X_2$)		
	A	B	C
100	—	—	—
95	1,5	1,8	2,0
90	3,0	3,6	3,9
85	4,5	5,4	5,9
80	6,0	7,2	7,8
75	7,5	9,0	9,8
50	7,5	9,0	9,8
25	7,5	9,0	9,8
20	6,0	7,2	7,8
15	4,5	5,4	5,9
10	3,0	3,6	3,9
5	1,5	1,8	2,0
0	—	—	—

If range ($X_1 - X_2$) \leq A, average the two results.

If range ($X_1 - X_2$) $>$ A and \leq B, do a third test.

If $X_{(\max)} - X_{(\min)} \leq B$, average the three results.

If $X_{(\max)} - X_{(\min)} > B$, do a fourth test.

If $X_{(\max)} - X_{(\min)} \leq C$, average the four results.

If $X_{(\max)} - X_{(\min)} > C$, discard $X_{(\max)}$ and $X_{(\min)}$, and average the remaining two results.

If range ($X_1 - X_2$) $>$ B and \leq C, do two more tests.

If $X_{(\max)} - X_{(\min)} \leq C$, average the four results.

If $X_{(\max)} - X_{(\min)} > C$, discard $X_{(\max)}$ and $X_{(\min)}$ and average the remaining two results.

If range ($X_1 - X_2$) $>$ C, do two more tests. Discard $X_{(\max)}$ and $X_{(\min)}$ and average the remaining two results.

The mean index shall be rounded off to the first decimal place.

ISO 4696:1984

<https://standards.iteh.ai/catalog/standards/sist/debc5317-67c6-47b9-83db-2a2285f91253/iso-4696-1984>