



Designation: D5796 – 20

Standard Test Method for Measurement of Dry Film Thickness of Thin-Film Coil-Coated Systems by Destructive Means Using a Boring Device¹

This standard is issued under the fixed designation D5796; the number immediately following the designation indicates the year of original adoption or, in the case of revision, the year of last revision. A number in parentheses indicates the year of last reapproval. A superscript epsilon (ϵ) indicates an editorial change since the last revision or reapproval.

1. Scope

1.1 This test method covers the measurement of dry film thickness (DFT) of coating films by microscopic observation of a precision-cut, shallow-angle crater bored into the coating film. This crater reveals cross sectional layers appearing as rings, whose width is proportional to the depth of the coating layer(s) and allows for direct calculation of dry film thickness.

1.1.1 The Apparatus, Procedure, and Precision and Bias discussions include Method A and Method B. Method A involves the use of an optical measurement apparatus which is no longer commercially available, but remains a valid method of dry film measurement. Method B is a software driven measurement procedure that supersedes Method A.

1.2 The substrate may be any rigid, metallic material, such as cold-rolled steel, hot-dipped galvanized steel, aluminum, etc. The substrate must be planar with the exception of substrates exhibiting “coil set,” which may be held level by the use of the clamping tool on the drilling device.

NOTE 1—Variations in the surface profile of the substrate may result in misrepresentative organic coating thickness readings. This condition may exist over substrates such as hot-dipped, coated steel sheet. This is true of all “precision cut” methods that are used to determine dry film thickness of organic coatings. This is why several measurements across the strip may be useful if substrate surface profile is suspect.

1.3 The range of thickness measurement is 0 to 3.5 mils (0 to 89 μm).

NOTE 2—For DFT measurements of films greater than 3.5 mils (89 μm), but less than 63 mils (1600 μm), a 45° borer may be used in accordance with this test method, with the exception of 6.8, where the micrometer reading would provide a direct read-out, and division by ten would be unnecessary per 4.3.1 Method A.

¹ This test method is under the jurisdiction of ASTM Committee D01 on Paint and Related Coatings, Materials, and Applications and is the direct responsibility of Subcommittee D01.53 on Coil Coated Metal.

Current edition approved July 1, 2020. Published July 2020. Originally approved in 1995. Last previous edition approved in 2015 as D5796 – 10 (2015). DOI: 10.1520/D5796-20.

1.4 Measurements may be made on coil-coated sheet, certain formed products, or on test panels.

1.5 The values stated in SI units are to be regarded as the standard. The values given in parentheses are for information only.

1.6 *This standard does not purport to address all of the safety concerns, if any, associated with its use. It is the responsibility of the user of this standard to establish appropriate safety, health, and environmental practices and determine the applicability of regulatory limitations prior to use.*

1.7 *This international standard was developed in accordance with internationally recognized principles on standardization established in the Decision on Principles for the Development of International Standards, Guides and Recommendations issued by the World Trade Organization Technical Barriers to Trade (TBT) Committee.*

2. Referenced Documents

2.1 *ASTM Standards:*²
D3794 Guide for Testing Coil Coatings

3. Significance and Use

3.1 Measurement of dry film thickness of organic coatings by physically cutting through the film and optically observing and measuring the thickness offers the advantage of direct measurement as compared with nondestructive means.

3.2 Constituent coating layers of an overall thickness of a coating system can usually be measured individually by this test method, provide adhesion between each layer is sufficient. (However, this can be difficult in cases where the primer, topcoat, or multiple coating layers have the same, or very similar, appearance.)

² For referenced ASTM standards, visit the ASTM website, www.astm.org, or contact ASTM Customer Service at service@astm.org. For *Annual Book of ASTM Standards* volume information, refer to the standard's Document Summary page on the ASTM website.

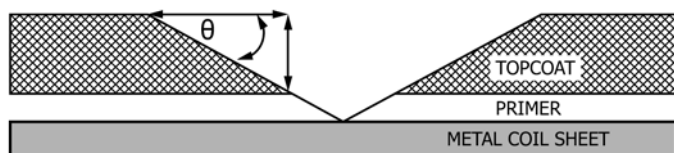

NOTE 1—The drawing is not to scale. It is for illustration purposes only.

NOTE 2— $\theta = 5.710593^\circ$

$\tan \theta = A/B = 0.1$

$A = 0.1B$

FIG. 1 Typical Crater Formed by Boring Device

4. Apparatus

4.1 *Dry Film Thickness Device*,³ It is an apparatus consisting of either a manual or automated carbide-tipped drill that raises and lowers the boring tip perpendicular to the surface to be tested, a cleaning brush, a marking device (optional), and a video imaging system, which is attached to a microscope that views the crater formed by the boring device.

4.2 *Carbide Borer Bit*, The configuration is designed to provide a very smooth circular incision in the paint film at a precise angle to the surface (see Fig. 1).⁴

4.3 *Optical Magnification*:

4.3.1 *Method A, Video Camera*—It is attached to an illuminated microscope and conveys the image onto a closed-circuit television (CCTV) monitor, so that it is an easy matter to line up the cross-hair on the enlarged image. This very effectively minimizes error or lack of consistency on the part of the operator in lining up the cross-hair.

4.3.2 *Method B, Computer Monitor*—It is attached to a microscope with external lighting and conveys the image via software onto a computer monitor. The monitor and software enlarge the image for viewing and measuring, while the computer retains the picture as an image file, if the user desires.

4.4 *Microscope*—The measurement is performed by first boring a shallow-angle crater of known configuration through the coating(s) film into the substrate. The microscope facilitates viewing and measuring the crater.

4.5 The instrument is calibrated by taking measurements on a standard, which is traceable to a national standards institution.⁵ Calibration is a procedure that is done during setup and will require recalibration if changes are made to the microscope, boring device, or the camera system. Calibration

³ The sole source of supply of the dry film thickness device known to the committee at this time is DJH Designs, 2366 Wyecroft Rd., Unit D4, Oakville, Ont., Canada L6L 6M1. If you are aware of alternative suppliers, please provide this information to ASTM International Headquarters. Your comments will receive careful consideration at a meeting of the responsible technical committee,¹ which you may attend.

⁴ The manufactured angle formed between the surface of the coating and the substrate is $5^\circ 42' 38''$ and the resulting crater is circular.

⁵ The supplier of the standard used to generate the precision statement and used for calibration (silver-plated, copper substrate) is DJH Designs. The DJH Designs standard is traceable to the NRC, Montreal Road Building M-36, Ottawa, Canada, K1A 0R6. An additional acceptable standard for calibration (copper and chromium coating on steel, SRM 1357) may be obtained from NIST, Standard Reference Materials Program, Building 202, Room 204, Gaithersburg, Maryland 20899. All standards must be traceable to the National Research Council or the National Institute of Science and Technology.

verification should be done at intervals agreed upon between the user and the consumer, but no less often than indicated by the manufacturer of the measuring device.

5. Test Specimens

5.1 If multiple coats of paint are to be measured, successive contiguous coats should be of contrasting colors to aid sharp discrimination of interfaces (see 3.2).

5.2 Generally, test specimens shall be prepared (as test panels) or chosen (as sites on a coil-coated sheet) to be representative of localized coating thickness and variability.

5.3 If test panels are to be laboratory prepared, this should be done using accepted industry practices, in accordance with Guide D3794.

6. Procedure

6.1 Select a test panel or choose a site for thickness measurement.

6.2 Using an appropriate surface marker⁶ of contrasting color, mark a line on the surface about 25-mm long and 12-mm wide. In most cases, the use of a marker is not necessary, but for certain colors, usually whites, its use may be desirable. Depending upon the coating and the type of marker used, it is possible for the marker to be absorbed into the coating, up to 0.2-mils (5- μm) deep. This effect can make it difficult to determine the position of the top edge of the crater. External fluorescent lighting may be positioned to enhance the image and eliminate the need for a marker. The use of a marker, lighting, or marker and lighting shall be agreed upon between the user and customer.

6.3 Select the appropriate borer bit. A typical bit used for coil coatings has a depth range of 0 to 2 mils, but others are available. The bit type and depth range shall be agreed upon between the user and customer.

6.4 Place the test panel on the borer stage (align the marked line, if required) so that it is positioned under the bit. Clamp the panel into place.

6.5 With a small brush, clean debris from the borer bit, the “depth stop surface,” and the surface of the test panel. Debris in these areas will result in a shallower and smaller crater, with consequently inaccurate results.

6.6 Adjust the depth control wheel so that the carbide borer bit just penetrates the metallic substrate, to avoid undue wear on the borer tip. This can only be done by trial and error due to substrate thickness variation.

6.7 If the boring device is automated, follow the instructions in 6.7.1; if the boring device is manually operated, follow the instructions in 6.7.2.

6.7.1 *Automated Boring Device*—Push the button to activate boring device. Do not make a second stroke into the same crater; do not allow the borer head to penetrate a previously tested crater.

⁶ The marker Sanford Sharpie, a registered trademark of Sanford, used by the committee at this time for this test method is Sanford Corp., Bellwood, IL 60104.

6.7.2 *Manual Boring Device*—Move the borer head down in a smooth, slow action to its full travel position, then immediately return it to its full rest position. Do not allow the borer head to rest in the “down” position; ragged edges or smeared coating may result, rendering accurate film measurement more difficult. Do not make a second stroke into the same crater; do not allow the borer head to penetrate a previously tested crater.

6.8 Place the test panel on the measure stage, and locate the crater on the monitor by moving the panel either with your hands, or with the two micrometers that control the movement of the stage.

6.9 If the viewing method is optical, follow the instructions in 6.9.1; if the viewing method is software generated, follow the instructions in 6.9.2.

6.9.1 *Method A, Optical Measurement*—Adjust the zoom lens to the maximum allowable zoom to fill the screen with the image of the crater. Re-center the crater, and focus. Adjust the lighting to give maximum visual contrast between coatings and coating/substrate. Align the cross-hair in the center of the crater, and using the micrometer adjustments that control the vertical and horizontal movement of the stage, move the cross-hair to the inner edge of the crater in the paint film for which the film thickness needs to be measured. Carefully align the outer edge of the cross-hair with the edge of the coating. Zero the micrometer. Then move the microscope stage with the micrometer adjustments so that the outer edge of the cross-hairs are aligned at the rim of the crater in the paint film. Determine the amount of travel from the micrometer and divide this reading by ten (10) to obtain the film thickness of the paint film (see Fig. 2 and Fig. 3).

6.9.1.1 The reading on the micrometer divided by ten will be the total mils dry film thickness (DFT). Repeat this procedure on the other side of the crater, and average the two readings.

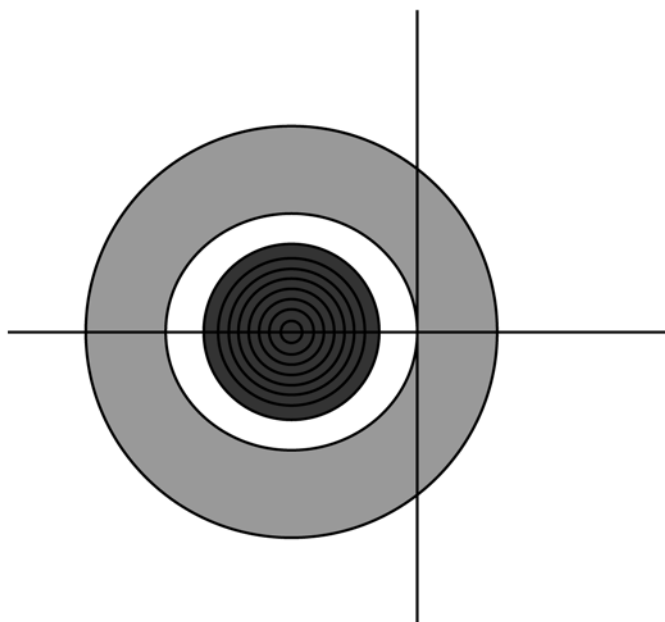

FIG. 3 Cross-Hair at Top Edge (Rim) of Crater

6.9.1.2 It may be possible to read both the primer and the topcoat film thicknesses (or any of the constituent layers of a multicoat system) separately. To acquire multicoat film measurements, each coating layer must exhibit good adhesion, which appears as a smooth circular cut without ragged edges or debris so a definite, visible delineation of the film layers is possible.

6.9.2 *Method B, Software Measurement*—Acquire the image by selecting the proper icon on the software menu. Turn the microscope lens so it zooms out and center the image of the crater on the screen by turning the micrometers attached to the stage. Zoom in again to fill the screen with the crater while adjusting the micrometers to maintain a fix on the image. Unlike Method A, you are not required to set the zoom at a set level for accurate film thickness measurement. Focus the microscope and adjust the lighting or other video options provided to make the picture more refined. Capture the image.

6.9.2.1 Choose the cross-hair icon and center it in the middle of the crater. Mark the points of delineation where the cross-hair and substrate (and other constituent layers) converge (see Fig. 4).

6.9.2.2 The average readings with respect to the placement of the identified points on the cross-hairs will appear on the screen along with the total average film build. The number of points chosen to measure determines the number average. If the user desires, the software will show each reading separately on the screen.

7. Report

7.1 Report the following information:

7.1.1 *Results of a Thickness Determination*—If more than one measurement is made and specific results for each location are not needed, report the average thickness of all readings and the number of readings taken. It is not necessary to drill more

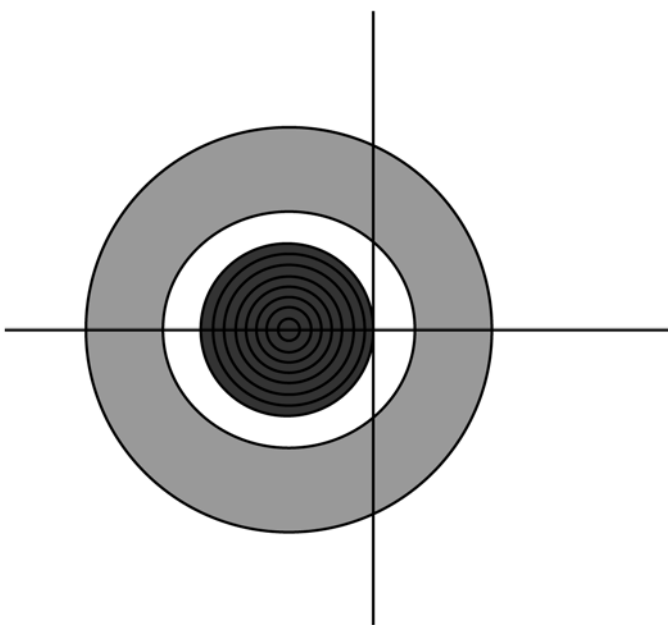

FIG. 2 Cross-Hair at Bottom (Inner Edge) of Crater