



Designation: F2824 – 10 (Reapproved 2020)

Standard Test Method for Mechanical Seal Strength Testing for Round Cups and Bowl Containers with Flexible Peelable Lids¹

This standard is issued under the fixed designation F2824; the number immediately following the designation indicates the year of original adoption or, in the case of revision, the year of last revision. A number in parentheses indicates the year of last reapproval. A superscript epsilon (ϵ) indicates an editorial change since the last revision or reapproval.

1. Scope

1.1 This test method describes a method for the measurement of mechanical seal strength while separating the entire lid (cover/membrane) from a rigid or semi-rigid round container.

1.2 This test method differs from Test Method F88. Test Method F88 tests a portion of the seal where as this test method tests the force required to separate the entire lid (cover/membrane) from the container.

1.3 This test method is used to determine the continuous and maximum forces required to separate the lid (cover/membrane) from the container.

1.4 This test method uses an angle of pull of 45°, however other angles of pull may be used provided results are documented noting the used angle of pull and said procedure is validated.

1.5 Typical examples of container shapes that could be tested using this or a similar method include oval, rectangular, and circular with single or multiple cavities having a sealed lid (cover/membrane). Examples of products packaged in these types of containers are: ready meals, creamers, coffee, yogurts, household fresheners, chemical and pharmaceutical products, and numerous others not mentioned. However, this test method, described within, is specifically for round containers.

1.6 The values stated in inch-pound units are to be regarded as standard. The values given in parentheses are mathematical conversions to SI units that are provided for information only and are not considered standard.

1.7 *This standard does not purport to address all of the safety concerns, if any, associated with its use. It is the responsibility of the user of this standard to establish appropriate safety, health, and environmental practices and determine the applicability of regulatory limitations prior to use.*

1.8 *This international standard was developed in accordance with internationally recognized principles on standard-*

ization established in the Decision on Principles for the Development of International Standards, Guides and Recommendations issued by the World Trade Organization Technical Barriers to Trade (TBT) Committee.

2. Referenced Documents

2.1 ASTM Standards:²

D4332 Practice for Conditioning Containers, Packages, or Packaging Components for Testing

E177 Practice for Use of the Terms Precision and Bias in ASTM Test Methods

E691 Practice for Conducting an Interlaboratory Study to Determine the Precision of a Test Method

F17 Terminology Relating to Primary Barrier Packaging

F88 Test Method for Seal Strength of Flexible Barrier Materials

2.2 Other Standard:

ANSI/AAMI/ISO 11607-1 Packaging for Terminally Sterilized Medical Devices—Part 1: Requirements for Materials, Sterile Barrier Systems, and Packaging Systems³

3. Terminology

3.1 Definitions of Terms Specific to This Standard:

3.1.1 *average seal strength*—the sum of the individual forces recorded divided by the total number of those measurements. The calculation can be expressed as the average between the peaks or within the peaks (see Fig. 1).

3.1.2 *flexible*—See Terminology F17.

3.1.3 *grip separation rate*—a function of the test equipment design and angle of peel to achieve the correct peel rate. It is the actual peel rate of separating the lid (cover/membrane) from the container. For this test method, the actual separation rate is 12 in./min (300 mm/min).

¹ This test method is under the jurisdiction of ASTM Committee F02 on Primary Barrier Packaging and is the direct responsibility of Subcommittee F02.20 on Physical Properties.

Current edition approved May 1, 2020. Published July 2020. Originally approved in 2010. Last previous edition approved in 2015 as F2824 – 10 (2015). DOI: 10.1520/F2824-10R20.

² For referenced ASTM standards, visit the ASTM website, www.astm.org, or contact ASTM Customer Service at service@astm.org. For *Annual Book of ASTM Standards* volume information, refer to the standard's Document Summary page on the ASTM website.

³ Available from American National Standards Institute (ANSI), 25 W. 43rd St., 4th Floor, New York, NY 10036, http://www.ansi.org.

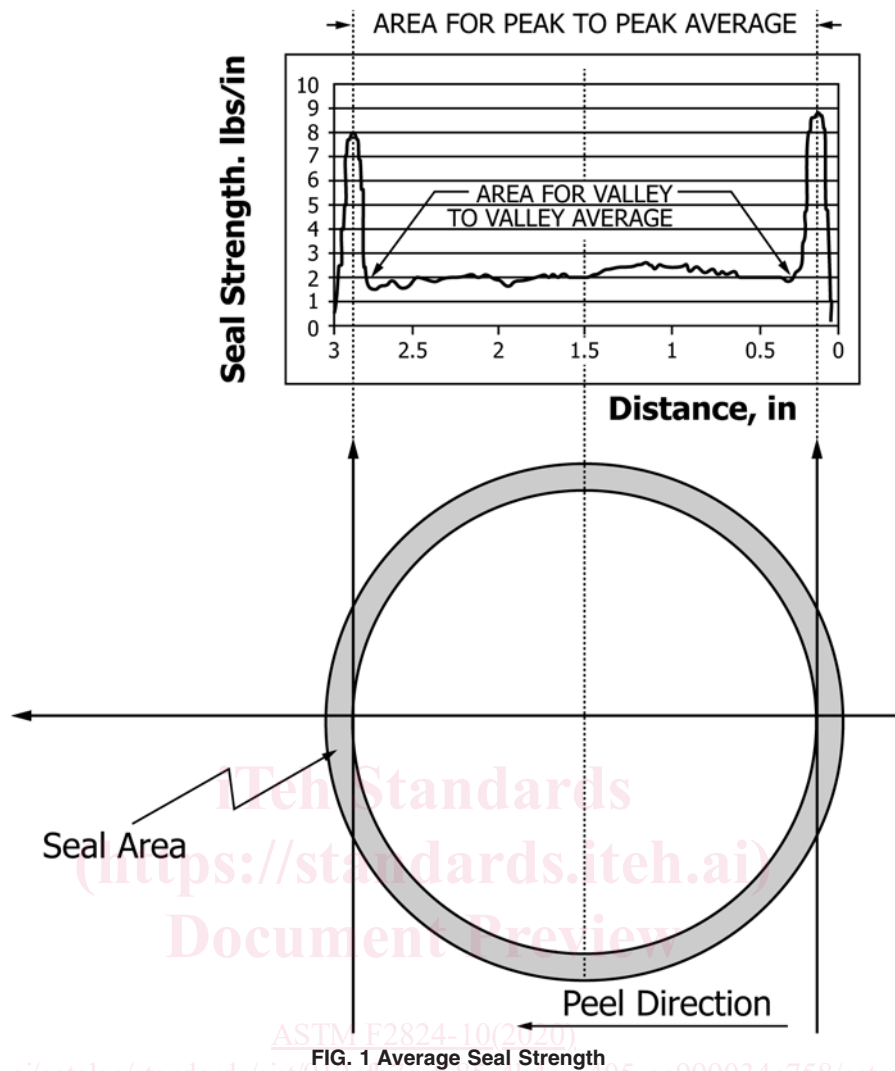

FIG. 1 Average Seal Strength

3.1.4 *maximum seal strength*—the maximum force measured when separating progressively, under the conditions of the test.

3.1.5 *peel angle*—the angle of the lid (cover/membrane) relative to the container seal surface at all points of removal of the lid (cover/membrane) from the container seal surface. The preferred angle for this test method is 45° (Fig. 2) but other angles can be used.

3.1.6 *peel line*—the line of direction of peel, normally 90° to the line beginning at the starting peel point and bisects the container area evenly (see Fig. 2).

3.1.7 *seal area*—the total area of the container which is sealed to the lid (cover/membrane) and requires a force to separate them.

3.1.8 *starting peel point*—the extended tab provided by the design of the lid (cover/membrane).

3.1.9 *work*—the energy required to separate the lid (cover/membrane) from the test container. Typically, this calculation is made by the computer software or can be calculated as the area under the force-displacement curve.

4. Summary of Test Method

4.1 The test sample (container) is fastened securely to the test fixture with the starting peel point (extended tab if provided) of the lid (cover/membrane) attached to the grip of the force measuring device (load cell). The lid (cover/membrane) is peeled from the container at a constant rate of speed along the peel line of the container and at a 45° angle (other angles are permitted but must be noted and reported with test results) measured from the sealed surface of the container and lid (cover/membrane). Forces measured during the test are recorded and plotted for analysis and reporting.

5. Significance and Use

5.1 Test Method F88 has been the standard for the mechanical peel strength testing of peelable seals since the 1960s. Normally the testing is run on a portion of the seal. The result is an actual seal strength picture of that portion of the seal. This test method is different in that the entire package seal is peeled open and data collected for the entire sealed area.

5.2 This test method is a tool for quality assurance use as well as performance evaluation of a seal during separation.

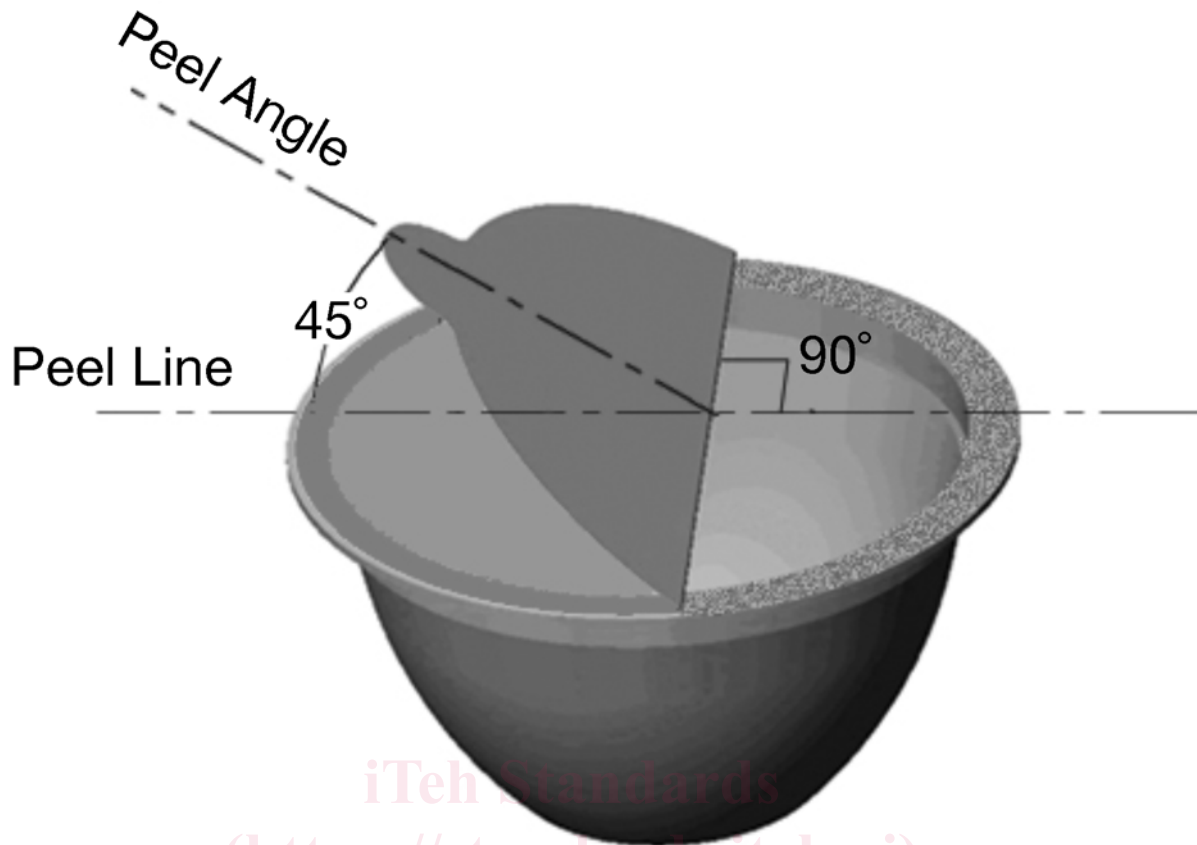

FIG. 2 Peel Line and Peel Angle

5.3 With appropriate software, data is collected depicting the seal strength of the entire length of the seal. As a result, it is possible to see seal strength variations, as the seal is peeled apart, thereby evaluating the consistency and uniformity of the seal (see Fig. 1).

6. Apparatus

6.1 Testing machine of the constant-rate-of-peel type shall be used.

6.2 The constant rate of peel between the clamp (grip) and the sample container shall be maintained at a constant rate of 12 ± 0.5 in./min (300 ± 12.7 mm/min).

6.3 There shall be an electronic measuring device (force gage) capable of taking a sufficient number of readings per second and compatible with the computer program such that a continuous graph of force versus displacement is achieved. It is also possible to use an analog instrument which inputs to an X-Y plotter to obtain the force versus displacement curve. A clamp or grip is fastened to the electronic measuring device and suitable for holding the lid (cover/membrane) shall be used (see Fig. 1).

6.4 There shall be a fixture suitable for securing the sample container in such a position as to cause the lid (cover/membrane) to be peeled at a constant 45° angle during the entire test. Since any movement of the container in the fixture can affect the value obtained by the electronic measuring device, the container must be held fast.

7. Sampling and Test Specs and Units

7.1 Sample size is determined by using an approved statistically validated sampling plan.

7.2 Sample identification should be made prior to specific test samples, if necessary. Record the information such that test results and anomalies are identifiable back to the individual specimens.

8. Preparation of Apparatus

8.1 Apparatus shall be positioned according to manufacturer's instructions and in a suitable environment for testing conditions.

9. Calibration and Standardization

9.1 Calibration of the force gage shall be verified prior to testing and accurate to $\pm 1\%$ of the full scale of the electronic measuring device.

9.2 Follow the gage manufacturer's procedure for calibration.

10. Conditioning

10.1 Conditioning of the samples will depend on the material under evaluation. If conditioning before testing is appropriate, normal, and desirable, then condition the test specimens at $23 \pm 2^\circ\text{C}$ ($73.4 \pm 3.6^\circ\text{F}$) and $50 \pm 5\%$ RH until material has reached stabilization. See Practice D4332 for guidance on conditioning practices.

11. Procedure

11.1 Verify calibration of the force-measuring device prior to proceeding with the test. See 9.2.

11.2 Determine the peel line of the sample container to be tested and secure the container in the test equipment fixture with the starting peel point and peel line oriented so that the direction of the peel travels along the peel line.

11.3 Secure the lid peeling tab in the grip of the force measuring device.

11.4 Set the rate of peel to 12 ± 0.5 in./min (300 ± 12.7 mm/min) and start the test.

11.5 Upon completion of the test cycle record the measured results, remove the sample, and repeat the process for additional samples.

12. Report

12.1 Report the following information:

12.2 Statement of the angle of peel that was used and any indication of any deviation from the test method as written.

12.3 Identification of the source, size, and shape of the sample tested along with any other necessary information to uniquely identify the sample.

12.4 Description of any anomalous behavior during the testing (such as tearing of the lid (cover/membrane)).

12.5 Measured values for: average seal strength, work, and maximum seal strength.

12.6 Sample conditioning if different than the test method.

13. Precision and Bias

13.1 The precision of this test method is based on an interlaboratory study (ILS) of ASTM WK18963 conducted in 2008. Four laboratories analyzed two different specimen types, reporting data for five peel strength parameters. Every “test result” represents an individual determination. The laboratories were instructed to report twenty replicate results for each parameter in order to estimate the repeatability and reproducibility limits of the standard. Except for the use of only four laboratories, Practice E691 was followed for the design and analysis of the data; the details are given in ASTM Research Report RR:F02-1028.⁴

⁴ Supporting data have been filed at ASTM International Headquarters and may be obtained by requesting Research Report RR:F02-1028. Contact ASTM Customer Service at service@astm.org.

13.1.1 *Repeatability Limit (r)*—Two test results obtained within one laboratory shall be judged not equivalent if they differ by more than the “*r*” value for that material; “*r*” is the interval representing the critical difference between two test results for the same material, obtained by the same operator using the same equipment on the same day in the same laboratory.

13.1.1.1 Repeatability limits are listed in Table 1 and Table 2 below.

13.1.2 *Reproducibility Limit (R)*—Two test results shall be judged not equivalent if they differ by more than the “*R*” value for that material; “*R*” is the interval representing the critical difference between two test results for the same material, obtained by different operators using different equipment in different laboratories.

13.1.2.1 Reproducibility limits are listed in Table 1 and Table 2 below.

13.1.3 The above terms (repeatability limit and reproducibility limit) are used as specified in Practice E177.

13.1.4 Any judgment in accordance with statements 13.1.1 and 13.1.2 would normally have an approximate 95 % probability of being correct, however the precision statistics obtained in this ILS must not be treated as exact mathematical quantities which are applicable to all circumstances and uses. The limited number of materials tested and laboratories reporting results guarantees that there will be times when differences greater than predicted by the ILS results will arise, sometimes with considerably greater or smaller frequency than the 95 % probability limit would imply. The repeatability limit and the reproducibility limit should be considered as general guides, and the associated probability of 95 % as only a rough indicator of what can be expected.

13.2 *Bias*—At the time of the study, the test specimens chosen for analysis were not accepted reference materials suitable for determining the bias for this test method, therefore no statement on bias is being made.

13.3 The precision statement was determined through statistical examination of 760 data points, from four laboratories, on a total of two unique material sets. These two different material types were described as the following:

- Material A: Gelatin cups
Cup: Thermoformed polypropylene
Lid: Foil lamination with peel layer
- Material B: Stuffing mix cups
Cup: Thermoformed multilayer plastic laminate
Lid: Plastic film with peel layer

TABLE 1 Gelatin Cups

Material	Average ^A	Standard Deviation of Laboratory Averages	Repeatability Standard Deviation	Reproducibility Standard Deviation	Repeatability Limit	Reproducibility Limit
	\bar{x}	$s_{\bar{x}}$	s_r	s_R	r	R
First Peak, lbf (N)	3.186 (14.172)	0.207 (0.921)	0.297 (1.321)	0.356 (1.584)	0.833 (3.705)	0.997 (4.435)
Second Peak, lbf (N)	4.408 (19.608)	0.148 (0.658)	0.396 (1.761)	0.414 (1.842)	1.110 (4.938)	1.158 (5.151)
Average Seal Strength, lbf (N)	1.525 (6.784)	0.142 (0.632)	0.076 (0.338)	0.161 (0.716)	0.213 (0.947)	0.450 (2.002)
Maximum Seal Strength, lbf (N)	4.391 (19.532)	0.146 (0.649)	0.417 (1.855)	0.432 (1.922)	1.169 (5.200)	1.210 (5.382)
Work, in.-lbf (N-m)	8.353 (0.9438)	0.527 (0.0595)	0.410 (0.0463)	0.661 (0.0747)	1.149 (0.1298)	1.852 (0.2092)

^A The average of the laboratories' calculated averages.