



Standard Test Method for Evaluating the Ability of Exterior Vents to Resist the Entry of Embers and Direct Flame Impingement¹

This standard is issued under the fixed designation E2886/E2886M; the number immediately following the designation indicates the year of original adoption or, in the case of revision, the year of last revision. A number in parentheses indicates the year of last reapproval. A superscript epsilon (ϵ) indicates an editorial change since the last revision or reapproval.

1. Scope*

1.1 This fire-test-response standard prescribes two individual methods to evaluate the ability of a gable end, crawl space (foundation) and other vents that mount on a vertical wall or in the under-eave area to resist the entry through the vent opening of embers and flame. The ability of such vents to completely exclude entry of flames or embers is not evaluated. Roof ridge and off-ridge (field) vents are excluded from this standard. Acceptance criteria are not provided in this standard.

NOTE 1—Test Method E2912 records information relevant to evaluate completely excluding the entry of flames through the venting device.

1.2 Ember entry and flame penetration are evaluated separately using different test procedures. A commentary and summary of the development of the ember test apparatus are given in Appendix X1.

1.3 These laboratory tests are used to evaluate the response of vents when subjected to ember and flame exposures under controlled conditions.

1.4 The values stated in either SI units or inch-pound units are to be regarded separately as standard. The values stated in each system are not necessarily exact equivalents; therefore, to ensure conformance with the standard, each system shall be used independently of the other, and values from the two systems shall not be combined.

1.5 Unless otherwise specified, the tolerance for dimensions in figures and text in this document shall be $\pm 5\%$.

1.6 This test method does not address interior fire spread.

1.7 *The standard is used to measure and describe the response of materials, products or assemblies to heat and flame under controlled conditions, but does not by itself incorporate all factors required for fire hazard or fire risk assessments of the materials, products or assemblies and other cladding materials under actual fire conditions.*

1.8 *This standard does not purport to address all of the safety concerns, if any, associated with its use. It is the*

responsibility of the user of this standard to establish appropriate safety, health, and environmental practices and determine the applicability of regulatory limitations prior to use.

1.9 *Fire testing is inherently hazardous. Adequate safeguards for personnel and property shall be employed in conducting these tests.*

1.10 *This international standard was developed in accordance with internationally recognized principles on standardization established in the Decision on Principles for the Development of International Standards, Guides and Recommendations issued by the World Trade Organization Technical Barriers to Trade (TBT) Committee.*

2. Referenced Documents

2.1 ASTM Standards:²

D1929 Test Method for Determining Ignition Temperature of Plastics

E108 Test Methods for Fire Tests of Roof Coverings

E176 Terminology of Fire Standards

E2257 Test Method for Room Fire Test of Wall and Ceiling Materials and Assemblies

E2707 Test Method for Determining Fire Penetration of Exterior Wall Assemblies Using a Direct Flame Impingement Exposure

E2912 Test Method for Fire Test of Non-Mechanical Fire Dampers Used in Vented Construction

2.2 California Standards Code:³

SFM 12-7A-1, Exterior Wall Siding and Sheathing, California Office of the State Fire Marshal, Sacramento, CA

SFM 12-7A-3, Under Eave, California Office of the State Fire Marshal, Sacramento, CA

3. Terminology

3.1 *Definitions*—For definitions of terms used in this test method refer to Terminology E176, Test Method E108, and Test Method E2912.

3.2 *Definitions of Terms Specific to This Standard:*

² For referenced ASTM standards, visit the ASTM website, www.astm.org, or contact ASTM Customer Service at service@astm.org. For *Annual Book of ASTM Standards* volume information, refer to the standard's Document Summary page on the ASTM website.

³ <https://up.codes/viewer/california/ca-referenced-standards-code-2016>

¹ This test method is under the jurisdiction of ASTM Committee E05 on Fire Standards and is the direct responsibility of Subcommittee E05.14 on External Fire Exposures.

Current edition approved July 1, 2020. Published August 2020. Originally approved in 2014. Last previous edition approved in 2014 as E2886/E2886M-14. DOI: 10.1520/E2886_E2886M-20.

*A Summary of Changes section appears at the end of this standard

3.2.1 *ember, n*—small burning or glowing pieces of vegetation or other cellulosic-based material.

3.2.2 *flaming combustion, n*—ignition of combustible material that results in flaming combustion.

3.2.3 *smoldering combustion, n*—ignition of combustible material where a transition to flaming combustion does not occur but a charred area indicating locations where embers landed can be observed.

3.2.4 *sustained flaming, n*—existence of flame on or over the surface of the vent for continuous periods of at least 4 s.

3.2.5 *unexposed side, n*—the face of the vent not directly exposed to the fire in the Flame Intrusion Test.

3.2.6 *vent, n*—a device or assembly placed in an exterior opening of a building (located in an eave, gable, wall, or foundation) that allows for aeration (free exchange of air).

4. Summary of Test Method

4.1 This test method contains two procedures to assess the ability of the vent to limit the entry of embers and flame penetration.

4.2 *Ember Intrusion Test*—This test method provides for a direct ember exposure to vents. The apparatus allows for embers to fall vertically and impinge on the vent mounted horizontally on ledges within the test chamber. An induction fan located at the bottom of the apparatus pulls the air stream through the vent, allowing any embers that pass through the vent to impinge on a combustible target material.

4.2.1 Observations are made for the occurrence of flaming combustion of the combustible target material during the time that embers are being generated and passing through the vent.

4.2.2 This test method utilizes a vertical air flow apparatus for the ember test.

4.3 *Flame Intrusion Test*—This test method provides for the evaluation of direct flame impingement on a vent mounted in a test assembly described in Test Method E2912.

4.3.1 The flame source is directed into the test assembly and directly impinges the vent that is mounted in either a vertical or horizontal position as described in Test Method E2912.

4.3.2 This test method employs a gas burner described in Test Method E2912 to produce flames that contact the vent.

4.3.3 The fuel flow rate from the burner shall produce a heat release rate of 300 ± 10 kW as described in Test Method E2912.

4.3.4 This test method includes an Integrity Test as described in Test Method E2912 to ascertain the presence of sustained flaming. The Integrity Test includes the following:

NOTE 2—Integrity is defined in Test Method E2912.

4.3.4.1 Visual observations are made for the presence and duration of any flame penetration through the vent.

4.3.4.2 An Ignition Test Procedure as described in Test Method E2912 is used to ascertain flaming combustion.

4.3.5 This test method includes an Insulation Test as described in Test Method E2912. The Insulation Test includes surface thermocouples to measure the temperature on the unexposed side of the vent.

5. Significance and Use

5.1 This test method evaluates the ability of exterior vents that mount vertically or horizontally to resist the entry of embers and flame penetration through the vent.

NOTE 3—A comparison study between the vertical air flow apparatus and a horizontal air flow apparatus, developed at the National Institute of Standards and Technology (NIST), has been conducted. A summary of the results of that comparison study are presented in Section X1.3 of the Appendix.

5.2 *Flame Intrusion Test*—Refer to the Significant and Use Section in Test Method E2912 for information related to the direct flame impingement on the vent.

6. Apparatus

6.1 *Apparatus for the Ember Intrusion Test:*

6.1.1 Diagrams of the ember intrusion apparatus are shown in Figs. 1-5. The apparatus consists of an ember generation chamber, a gas burner, a drive unit with controls, a flame chamber, a test cabinet and an exhaust fan.

6.1.2 *Ember Generation Chamber (Circular Tumbler):*

6.1.2.1 The circular tumbler shall be fabricated from 13 mm [0.5 in.] by 1.5 mm [0.059 in.] flattened expanded metal wrapped around four 6 mm [0.25 in.] diameter bracing rods that are equally spaced around the perimeter and connected on each end to 203 mm [8 in.] diameter, 8 mm [0.3125 in.] thick steel end disc plates. The end disc plates shall be 457 mm [18 in.] apart, forming a cylinder that is 203 mm [8 in.] in diameter and 457 mm [18 in.] in length.

6.1.2.2 The circular tumbler shall have a hinged door also made of the 13 mm [0.5 in.] by 1.5 mm [0.059 in.] flattened expanded steel, approximately 140 mm by 89 mm [5.5 in. by 3.5 in.] arched to match the curve of the tumbler and located in the center of the tumbler between one end plate and the other. The orientation of the access door shall be such that the 89 mm [3.5 in.] dimension is measured along the circumference of the cylinder. The hinges of the access door shall be located along the 140 mm [5.5 in.] dimension of the door.

6.1.2.3 A 25.4 mm (+0 mm / -0.1 mm) [1 in. (+0 in. / -0.004 in.)] diameter cold rolled steel bar shall be connected to the center of each of the 203 mm [8 in.] round plates of the tumbler. These bars shall act as an axle. Each bar shall be 76 mm [3 in.] in length and shall be welded on one end to the outside centers of each plate. The centerline of the bars shall match the centerline of the tumbler. Both bars shall pass through their respective 25.4 mm (+0.1 mm / -0 mm) [1 in. (+0.004 in. / -0 in.)] (inside diameter) bearing pillow block which shall be mounted to the frame with two 6 mm, 10 threads per cm [M6×1] by 32 mm length [0.25 in. - 20 by 1.25 in.] machine bolts each. The bearings shall be located 13 mm [0.5 in.] from the 203 mm [8 in.] round end plates. A 20-tooth ISO 08B roller chain sprocket with 25.4 mm [+0.1 mm / -0 mm] inside bore diameter [20-tooth by ANSI #40 roller chain sprocket with 1-in. inside diameter] shall be affixed on the axle shaft on the side of the drive assembly.

6.1.2.4 While in operation, the tumbler shall be shielded with a hinged hood. The hood shall be a two piece clam shell style that overlaps at the top by 25 mm [1 in.]. The hood shall be formed using 0.8 mm [0.031 in.] sheet metal with 19 mm [0.75 in.] wide flat bar reinforcing at the perimeter. The flat bar

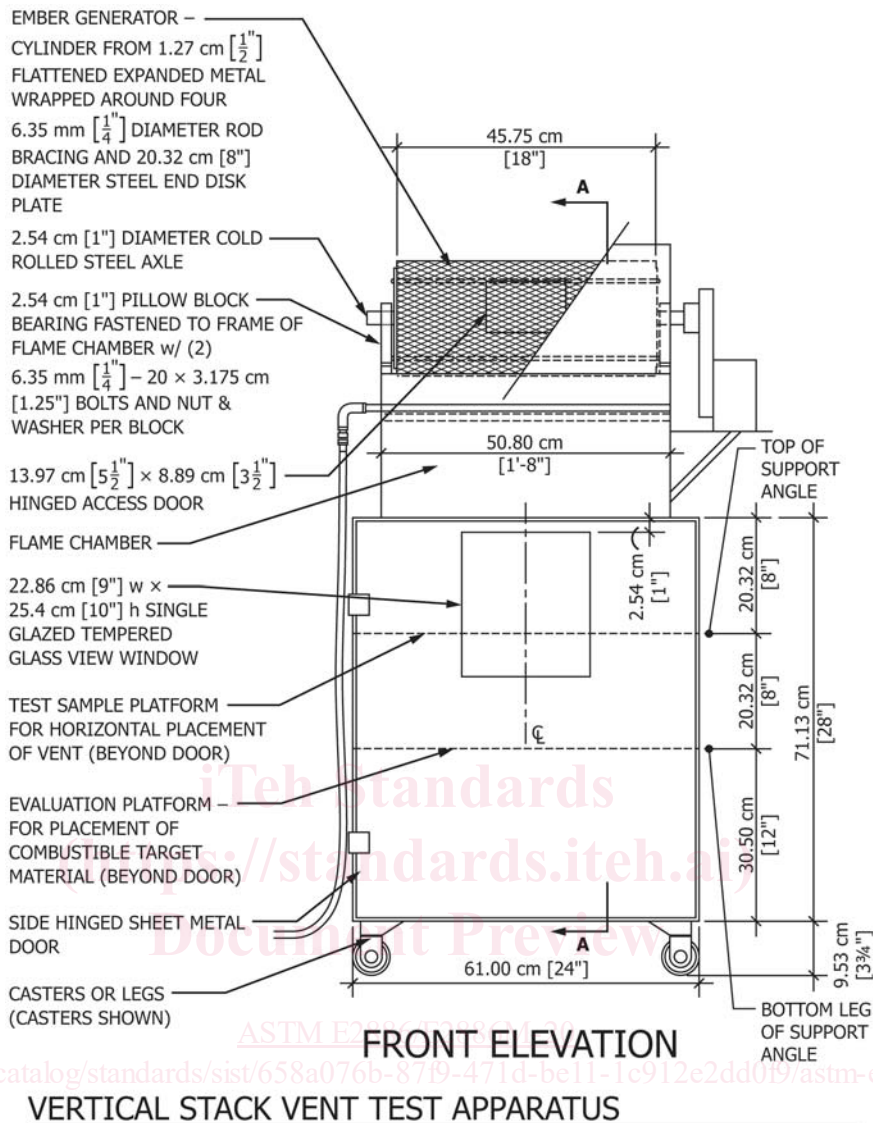

FIG. 1 Ember Apparatus, Front View

stock shall be attached to the sheet metal hood with pop rivets. When closed the hood shall be arched to have a diameter of 254 mm [10 in.]. Each of the two pieces that make up the hood shall be 495 mm [19.5 in.] wide.

6.1.3 The drive unit shall consist of a motor, gear box, chain and sprockets and controls.

6.1.3.1 The motor shall be a ¼ HP National Electrical Manufacturers Association (NEMA) 56C C-face mount single phase AC motor, 1725 rpm, and shall be mounted to a metal cantilevered shelf. The metal shelf shall be made from a 5 mm [0.1875 in.] plate, 305 mm [12 in.] wide and 184 mm [7.25 in.] deep with metal knee braces tack welded to the left side of the flame chamber.

6.1.3.2 The gear box shall be a 0.35 HP maximum, NEMA 56C C-face input, left hand output by 22.2 mm [0.875 in.] round shaft, 60:1 ratio and shall be mounted to the same shelf as the motor.

6.1.3.3 The drive chain and sprockets shall be International Organization for Standardization (ISO) 08B (#40) roller chain,

ISO 08B (4020) BS 22.2 mm [0.875 in.] gear box sprocket and ISO 08B (4020) BS 25 mm [1 in.] sprocket. The drive chain shall be guarded with sheet metal or expanded steel for operational safety.

6.1.3.4 When activated, the circular tumbler shall rotate at 30 rev/min.

6.1.4 The controls shall have three switches: one for the fan, one for the drive motor, and one for the fan and drive motor together.

6.1.5 The flame chamber shall be centered directly below the tumbler. The flame chamber shall be constructed with a framework of 19 by 19 mm [0.75 by 0.75 in.] steel angle and skinned with 2 mm [0.078 in.] sheet metal panels on four sides. The top and bottom of the box shall be open to allow the embers to flow through. The chamber shall be 228 mm [9 in.] deep, 508 mm [20 in.] wide and 254 mm [10 in.] tall.

6.1.5.1 The burner shall consist of a 13 mm [0.5 in.] round black iron gas pipe with fifteen 2.4 mm [0.09375 in.] round holes equally spaced at 19 mm [0.75 in.] in a straight pipe. The

EXHAUST FAN REQUIREMENTS:
 EXHAUST DUCT TO CONNECT TO FAN THAT IS UL LISTED – 30LS, 115v 60 Hz
 81 watts 0.7 amps, THERMALLY PROTECTED – MAX. TEMP 60°C [140°F], AMCA
 CERTIFIED FOR SOUND AND AIR PERFORMANCE, FAN TECH MODEL FX6 OR
 EQUIVALENT

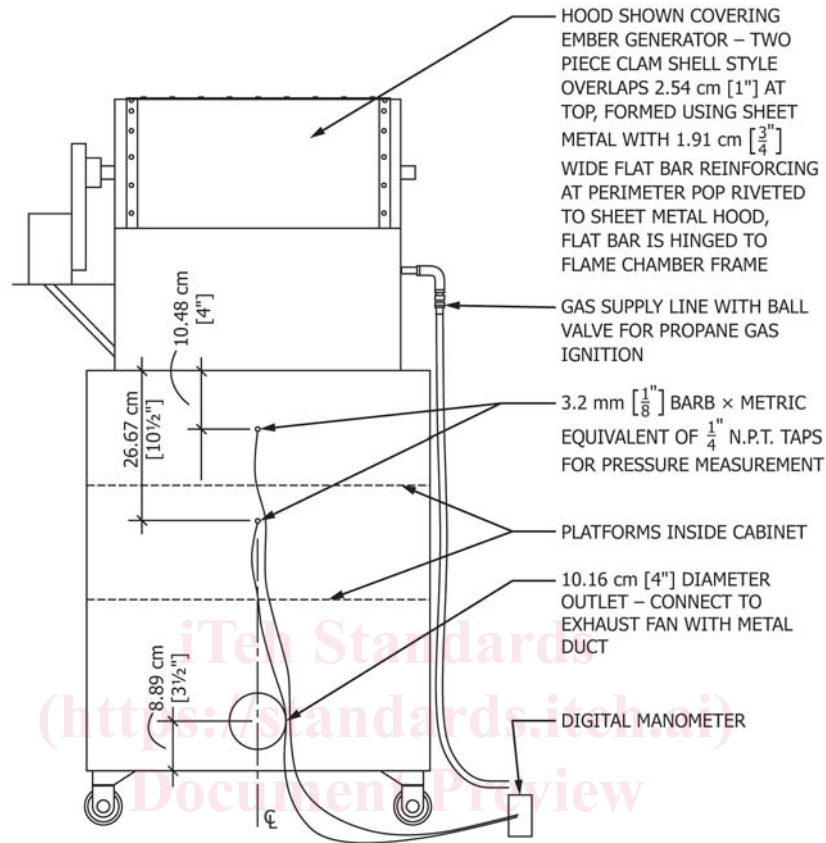

REAR ELEVATION
 VERTICAL STACK VENT TEST APPARATUS

FIG. 2 Ember Apparatus, Rear View

pipe shall run horizontally, parallel with the tumbler. The distance between the bottom of the tumbler and the center of the gas pipe shall be 57 mm [2.25 in.]. The first hole in the pipe shall be located 95 mm [3.75 in.] from the left wall of the flame chamber. The last hole shall be located 362 mm [14.25 in.] from the left wall of the flame chamber.

6.1.5.2 The burner pipe shall be connected to the left and right side of the flame chamber, exiting on the left where it shall be attached to a gas supply line with ball valve.

6.1.6 Test Cabinet:

6.1.6.1 The test cabinet shall be a rectangular steel box, 381 mm [15 in.] deep, 610 mm [24 in.] wide and 711 mm [28 in.] tall. It shall be centered below the flame chamber and shall rest on four casters or legs that are 95 mm [3.75 in.] tall. The test cabinet shall have an opening in the top, through to the flame chamber, which is 190 mm [7.5 in.] deep and 457 mm [18 in.] wide positioned so that it is centered from left-to-right and from front-to-back in the top of the test cabinet. The test cabinet shall have an interior framework of welded 32 by 32

mm [1.25 by 1.25 in.] angle iron and skinned with 2 mm [0.078 in.] sheet metal panels.

6.1.6.2 The front side of the test cabinet shall consist of a left-hinged 2 mm [0.078 in.] door with a glazed tempered-glass view window, and two latches on the right side to hold the door securely closed during testing. The door shall be framed out with 32 by 32 mm [1.25 by 1.25 in.] by 3 mm [0.125 in.] thick angle iron or equivalent material.

6.1.6.3 The view window shall be 229 mm [9 in.] wide and 254 mm [10 in.] high. The window shall be centered left-to-right and the top of the window shall be 25 mm [1 in.] from the top of the door it is mounted in.

6.1.7 Two shelves shall be mounted inside the test chamber.

6.1.7.1 Upper Shelf:

(1) The upper shelf shall serve as a platform for the vent and shall be located 203 mm [8 in.] from the top of the chamber.

6.1.7.2 The upper shelf shall have a ledge on four sides made of 25 mm by 25 mm [1 in. by 1 in.] by 3 mm [0.125 in.]

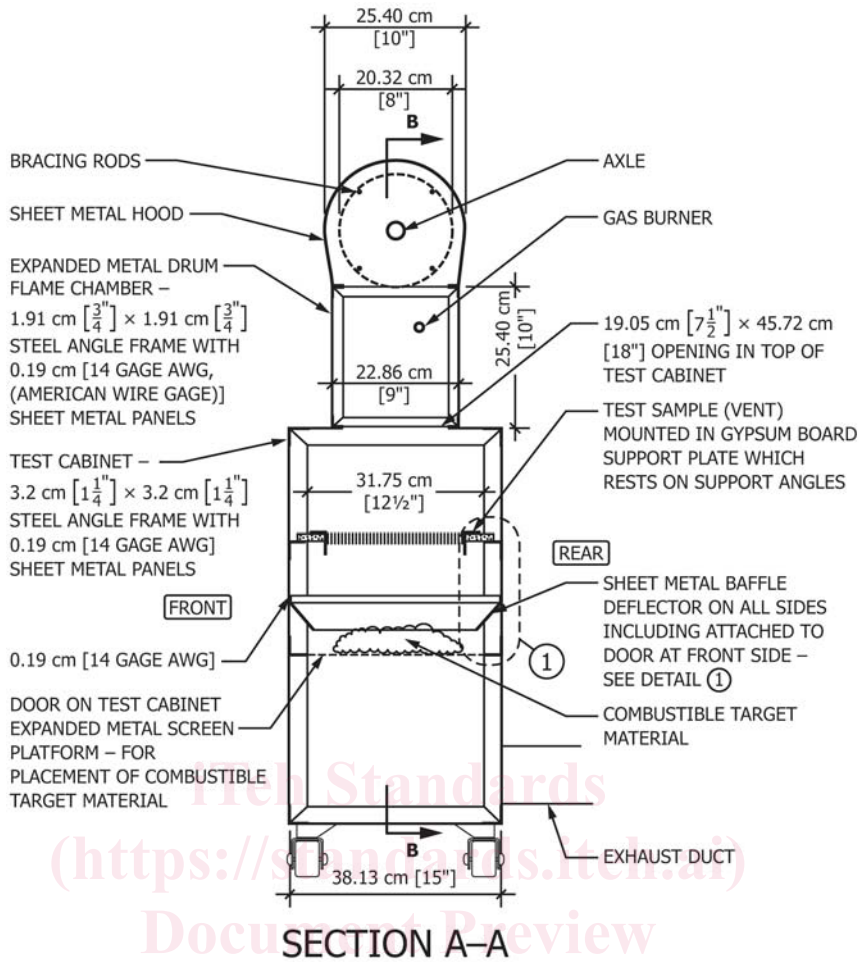

VERTICAL STACK VENT TEST APPARATUS

FIG. 3 Ember Apparatus, Section A-A, Side View

steel angle welded to the interior cabinet walls. A piece of gypsum board, nominal 13 mm [0.5 in.] thick, shall be cut to size to fit on top of the angle iron frame. The gypsum board shall be cut appropriately to center the vent under the tumbler. The edges between the vent and gypsum board shall be sealed.

6.1.7.3 The gypsum board section shall be scored in the 305 mm [12 in.] depth direction, approximately 13 mm [0.5 in.] from the edge, to allow for folding of the section, and facilitate insertion and removal of the vent in the apparatus.

6.1.8 Lower Shelf:

6.1.8.1 The lower shelf shall be located 406 mm [16 in.] from the top of the chamber. The shelf shall have a ledge on four sides made of 25 by 25 mm [1 by 1 in.] by 3 mm [0.125 in.] thick steel angle welded to the interior cabinet walls. A piece of 13 mm [0.5 in.] by 1.5 mm [0.059 in.] flattened expanded metal screen shall rest on the ledge of the angle iron and be tack welded to it.

6.1.8.2 The lower shelf shall be used to support the combustibile test media that will be used to evaluate vent performance.

6.1.9 The test cabinet shall have sheet metal baffle deflectors attached on all four interior cabinet walls, including the back

side of the door. These baffles shall be located between the upper and lower shelf.

6.1.9.1 The baffles are designed to funnel test embers away from the edge of the combustibile target media without resulting in an accumulation of embers along the outside edge.

6.1.9.2 The baffles shall be fabricated from 76 mm [3 in.] strips of 1 mm [0.051 in.] sheet metal that is tack welded or bolted to the interior cabinet walls and door.

6.1.9.3 The baffles shall have a 19 mm [0.75 in.] tab as an attachment point and bent to angle inward at 45 degrees from another 57 mm [2.25 in.].

6.1.10 There shall be a 102 mm [4 in.] round hole in the back wall of the cabinet, centered from side-to-side and located 89 mm [3.5 in.] from the bottom of the cabinet. The steel edge around the hole shall be used to attach a metal collar.

6.1.10.1 A 915 mm [3 ft] section of sheet metal ducting shall be attached to the outlet collar at one end and to the exhaust fan at the other end.

6.1.10.2 The exhaust fan shall be a 30LS, 115 VAC, 60 Hz, 81 W, 0.7 A thermally-protected [maximum temperature 140°F] fan. The fan shall be used to draw air through the apparatus.

ROTATING EMBER GENERATOR DRIVE REQUIREMENTS:

MOTOR – $\frac{1}{4}$ hp NEMA 56C C-FACE MOUNT SINGLE PHASE AC MOTOR 1725 rpm

GEAR BOX – .35 HP MAX. INPUT NEMA 56C INPUT LEFT HAND OUTPUT
 × 2.22 cm (.875") DIAMETER SHAFT, 60:1 RATIO

DRIVE CHAIN/SPROCKETS – CHAIN IS ISO 08B (ANSI #40);

GEAR BOX SPROCKET IS ISO 08B/20 TOOTH (ANSI 4020) BORED TO 2.22 cm (.875");

CAGE SPROCKET IS ISO 08B/20 TOOTH (ANSI 4020) BORED TO 2.54 cm (1")

CONTROLS:

(3) MAINTAINED SWITCHES – FAN, DRUM, AND FAN/DRUM, EA. WITH ON-OFF SELECTIONS

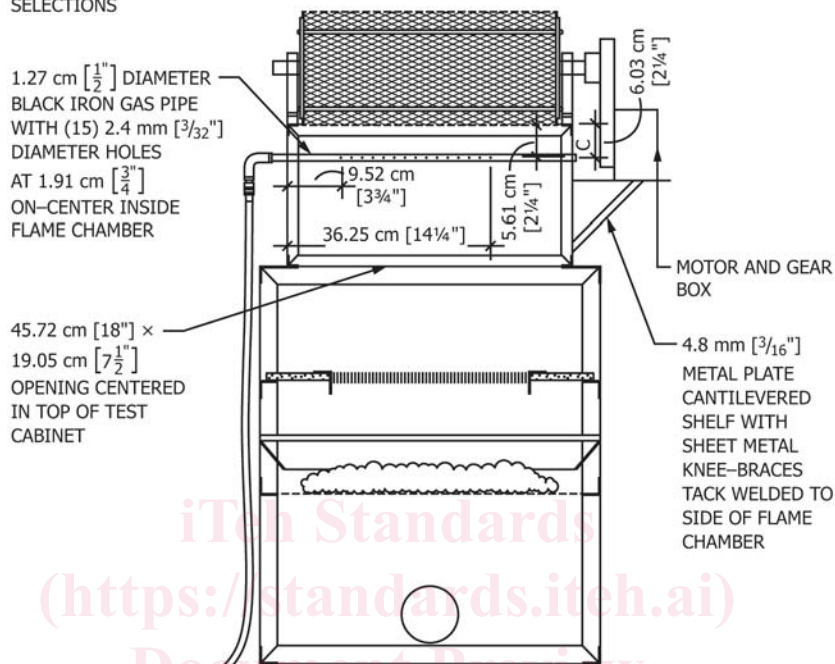

FIG. 4 Ember Apparatus, Internal Baffle Deflector Detail

6.1.10.3 The fan shall have variable speed control adjustment and the control shall be adjusted such that with a 6 mm [0.25 in.] screen mesh with 0.64 mm [0.025 in.] wire, covering the entire upper shelf, and the prescribed expanded steel covering the lower shelf, the wind velocity shall have an average speed of 0.9 m/s [2.0 mph].

(1) Velocity shall be measured 38 mm [1.5 in.] above the upper shelf.

6.1.11 Three thermocouples (Type K, 18 B&S gauge (1 mm [0.04 in.])) shall be positioned at a height of 25 mm [1 in.] directly over and along the center line of the width of the vent. One thermocouple shall be placed above the center of the vent. The remaining two thermocouples shall be placed on each side of the center thermocouple at distance halfway between the center thermocouple and the outer edge of the vent. Temperature readings shall be taken at 1-s intervals over the entire length of the test.

6.2 Apparatus for the Flame Intrusion Test:

6.2.1 Fire Source—Refer to the Apparatus Section and “Fig. 1 Gas Burner Exposure Fire Source” in Test Method E2912 for the burner and fuel source needed to produce the fire source and conduct the Flame Intrusion Test on the vent.

NOTE 4—The burner and its output were selected to produce a sudden direct flame impingement on the test specimen that is constant. The burner configuration and its output were based upon those prescribed in Test

Method E2257. The distance between the test specimen and the fire source (gas burner) was set to address variables typically seen in building occupation that contribute to sudden direct flaming. Two of many possible examples are: (1) Exterior vents located near storage areas where combustibles are stacked such as wood piles, (2) Exterior vents in contact with landscaping (vegetation or forestation, or both). In many cases, these combustibles are just inches from the vent, which is open to allow airflow, and are subject to a sudden direct flame impingement.

6.2.2 Test Assembly—Refer to the Apparatus Section in Test Method E2912 for the test bench (as shown in Figs. 2-9, inclusive, in Test Method E2912).

6.2.3 Cotton Pads and Applicator Frame—Refer to the Apparatus Section and the Annex in Test Method E2912 for the type of cotton pads and applicator frame (as shown in Figs. A1.1 and A1.2 in Test Method E2912).

6.2.4 Unexposed Surface Thermocouples—Refer to the Apparatus Section in Test Method E2912 for the type of unexposed surface thermocouples.

6.2.5 Thermocouple Pads—Refer to the Apparatus Section in Test Method E2912 for the type of thermocouples pads.

6.2.6 Other Detection and Observation Devices—A video camera is permitted to document the presence and duration of any flame penetration through the vent. When desired, refer to the Apparatus Section in Test Method E2912 for other thermal detection devices that are permitted.

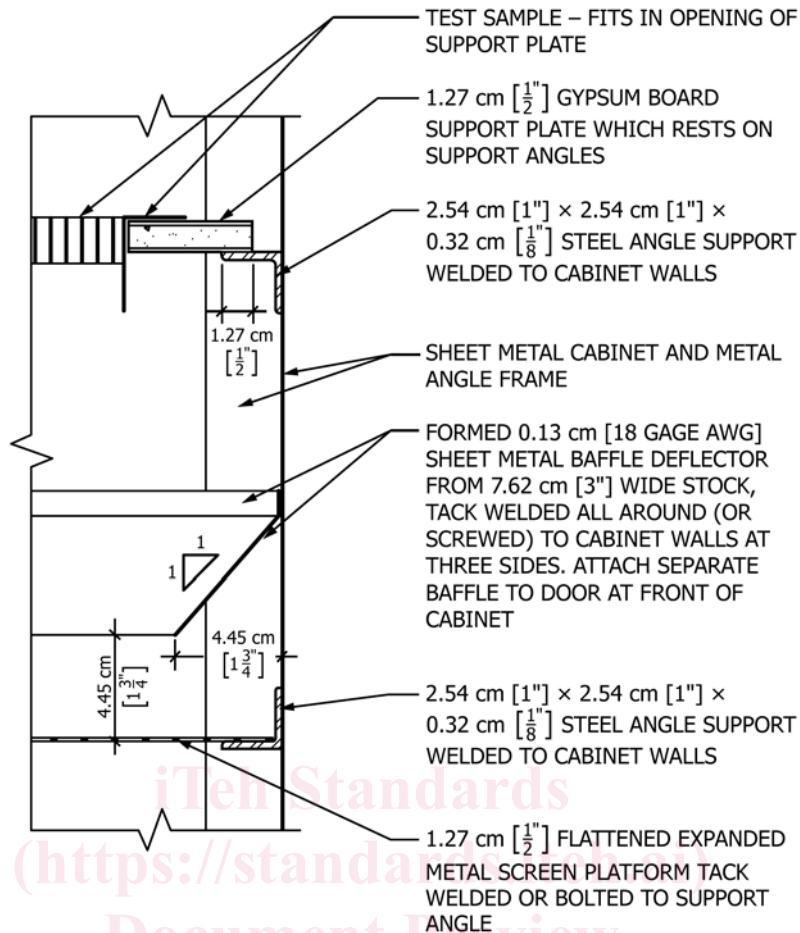

1 BAFFLE DEFLECTOR DETAIL

VERTICAL STACK VENT TEST APPARATUS

FIG. 5 Baffle Deflector Detail, Section 1

6.2.7 *Time Measurement*—Refer to the Apparatus Section in Test Method E2912 for the type of time measurement devices.

7. Test Specimen

7.1 The test specimen is the vent. The test specimen shall be representative of the vent as used in practice. Document a detailed description of the vent with respect to materials, components, workmanship, and details. The same model number (type) of vent shall be used in both the Ember Intrusion Test and Flame Intrusion Test.

7.2 *Ember Intrusion Test:*

7.2.1 *Test Specimen Size*—Some vents are larger than what the test apparatus will accommodate. When necessary, the vent shall be reduced in length or width while maintaining the same design features in order to fit into the ember test apparatus. Document the dimensions of the test specimen tested. Photograph the vent used in the Ember Intrusion Test.

NOTE 5—The maximum sized vent that the test chamber will accommodate is 330 by 533 mm [13 by 21 in.].

7.2.2 *Test Specimen Installation*—Document the installation of the vent and all materials used.

7.3 *Flame Intrusion Test:*

7.3.1 *Test Specimen Splices*—Refer to and follow the Test Specimen and Test Assembly Section requirements in Test Method E2912 related to splices.

7.3.2 *Test Specimen Size*—Refer to and follow the Test Specimen and Test Assembly Section requirements in Test Method E2912 related to size.

7.3.3 *Test Specimen Installation*—Refer to and follow the Test Specimen and Test Assembly Section requirements in Test Method E2912 related to installation.

7.3.4 *Horizontal Test Specimens*—Refer to and follow the Test Specimen and Test Assembly Section requirements in Test