



Designation: **F3347–20 F3347 – 20a**

Standard Specification for Metal Press Insert Fittings with Factory Assembled Stainless Steel Press Sleeve for SDR9 Cross-linked Polyethylene (PEX) Tubing and SDR9 Polyethylene of Raised Temperature (PE-RT) Tubing¹

This standard is issued under the fixed designation F3347; the number immediately following the designation indicates the year of original adoption or, in the case of revision, the year of last revision. A number in parentheses indicates the year of last reappraisal. A superscript epsilon (ϵ) indicates an editorial change since the last revision or reappraisal.

1. Scope*

1.1 This specification covers copper alloy metal press insert fittings with factory assembled stainless steel press sleeves incorporating 3 view holes and tool locator ring. These fittings are for use with cross-linked polyethylene (PEX) tubing in nominal sizes $\frac{5}{16}$, $\frac{3}{8}$, $\frac{1}{2}$, $\frac{5}{8}$, $\frac{3}{4}$, 1, $1\frac{1}{4}$, $1\frac{1}{2}$, and 2 that meet the requirements for Specification **F876** or **F3253** and for use with polyethylene of raised temperature (PE-RT) tubing in nominal sizes $\frac{3}{8}$, $\frac{1}{2}$, $\frac{3}{4}$, 1, $1\frac{1}{4}$, $1\frac{1}{2}$, and 2 that meet the requirements of Specification **F2769**. These fittings are intended for use in 100 psi (689.5 kPa) systems operating at temperatures up to, and including, 180 °F (82 °C). The requirements for materials, workmanship, dimensions, and markings to be used on the fittings and sleeves are also included. The components covered by this specification are intended for use in residential and commercial, hot and cold, potable water distribution systems as well as sealed central heating, including under-floor heating/cooling systems, and residential fire sprinkler systems.

1.2 *Units*—The values stated in inch-pound units are to be regarded as standard. The values given in parentheses are mathematical conversions to SI units that are provided for information only and are not considered standard.

1.3 *This standard does not purport to address all of the safety concerns, if any, associated with its use. It is the responsibility of the user of this standard to establish appropriate safety, health, and environmental practices and determine the applicability of regulatory limitations prior to use.*

1.4 *This international standard was developed in accordance with internationally recognized principles on standardization established in the Decision on Principles for the Development of International Standards, Guides and Recommendations issued by the World Trade Organization Technical Barriers to Trade (TBT) Committee.*

2. Referenced Documents

2.1 ASTM Standards:²

[A269/A269M Specification for Seamless and Welded Austenitic Stainless Steel Tubing for General Service](#)

[B124/B124M Specification for Copper and Copper Alloy Forging Rod, Bar, and Shapes](#)

[B16/B16M Specification for Free-Cutting Brass Rod, Bar and Shapes for Use in Screw Machines](#)

[B283/B283M Specification for Copper and Copper-Alloy Die Forgings \(Hot-Pressed\)](#)

[B371/B371M Specification for Copper-Zinc-Silicon Alloy Rod](#)

[B584 Specification for Copper Alloy Sand Castings for General Applications](#)

[D1600 Terminology for Abbreviated Terms Relating to Plastics](#)

[D2122 Test Method for Determining Dimensions of Thermoplastic Pipe and Fittings](#)

[E92 Test Methods for Vickers Hardness and Knoop Hardness of Metallic Materials](#)

[F412 Terminology Relating to Plastic Piping Systems](#)

[F876 Specification for Crosslinked Polyethylene \(PEX\) Tubing](#)

[F877 Specification for Crosslinked Polyethylene \(PEX\) Hot- and Cold-Water Distribution Systems](#)

¹ This test method is under the jurisdiction of ASTM Committee **F17** on Plastic Piping Systems and is the direct responsibility of Subcommittee **F17.10** on Fittings. Current edition approved Feb. 1, 2020/July 1, 2020. Published February 2020/July 2020. Originally approved in 2018. Last previous edition approved in 2019/2020 as F3347–19a–20. DOI: 10.1520/F3347–2010.1520/F3347–20A

² For referenced ASTM standards, visit the ASTM website, www.astm.org, or contact ASTM Customer Service at service@astm.org. For *Annual Book of ASTM Standards* volume information, refer to the standard's Document Summary page on the ASTM website.

*A Summary of Changes section appears at the end of this standard

~~[F2769 Specification for Polyethylene of Raised Temperature \(PE-RT\) Plastic Hot and Cold-Water Tubing and Distribution Systems](#)~~

~~[F3253 Specification for Crosslinked Polyethylene \(PEX\) Tubing with Oxygen Barrier for Hot- and Cold-Water Hydronic Distribution Systems](#)~~

~~2.2 ASME Standards:³~~

~~[B584 Specification for Copper Alloy Sand Castings for General Applications](#)~~

~~[D1600 Terminology for Abbreviated Terms Relating to Plastics](#)~~

~~[D2122 Test Method for Determining Dimensions of Thermoplastic Pipe and Fittings](#)~~

~~[E92 Test Methods for Vickers Hardness and Knoop Hardness of Metallic Materials](#)~~

~~[F412 Terminology Relating to Plastic Piping Systems](#)~~

~~[F876 Specification for Crosslinked Polyethylene \(PEX\) Tubing](#)~~

~~[F877 Specification for Crosslinked Polyethylene \(PEX\) Hot- and Cold-Water Distribution Systems](#)~~

~~[F3253 Specification for Crosslinked Polyethylene \(PEX\) Tubing with Oxygen Barrier for Hot- and Cold-Water Hydronic Distribution Systems](#)~~

~~2.2 ASME Standards:³~~

~~[B1.20.1 Pipe Threads General Purpose \(Inch\)](#)~~

~~[B16.18 Cast Copper Alloy Solder Joint Pressure Fittings](#)~~

~~[B16.22 Wrought Copper and Copper Alloy Solder Joint Pressure Fittings](#)~~

~~2.3 Manufacturer's Standardization Society Standard:⁴~~

~~[MSS SP-104 Wrought Copper Solder Joint Pressure Fittings](#)~~

~~2.4 NSF/ANSI Standards:⁵~~

~~[Standard 14 Plastic Piping Components and Related Materials](#)~~

~~[Standard 61 Drinking Water System Components-Health Effects](#)~~

~~[Standard 372 Drinking Water System Components-Lead Content](#)~~

~~2.5 EN Standard:⁶~~

~~[EN 1982 Copper and Copper Alloys, Ingots and Castings](#)~~

3. Terminology

3.1 Unless otherwise specified, definitions, abbreviations and initialisms are in accordance with Terminology [F412](#) and Terminology [D1600](#).

3.2 Definitions:

3.2.1 *metal press insert fitting, n*—A type of piping component that is pushed into the open end of the plastic tubing and attaches by mechanically pressing and deforming an outer stainless steel sleeve over the outside diameter of the plastic tubing. The seal is realized between the outer diameter of the insert fitting and the inner diameter of the plastic tubing. Mechanical pressing is achieved by the use of a press tool.

3.2.2 *press sleeve, n*—Cylindrical shaped stainless steel ring which is compressed with a pressing tool while located over the PEX tubing securing it permanently to the underlying insert fitting.

3.2.3 *press tool, n*—A device by which the stainless sleeve is compressed by a forming die that is radially closed down on the press sleeve by either hand powered or electro-mechanical pressing action.

4. Classification

4.1 This specification covers one class of fittings and stainless steel press sleeve suitable for use with PEX tubing that meet either the requirements of Specification [F876](#) or [F3253](#), or with PE-RT tubing that meets the requirements of Specification [F2769](#).

5. Materials and Manufacture

5.1 *Fittings*—The fittings shall be made from one of the following metals:

5.1.1 *Cast Copper Alloys*—Cast copper alloy fittings shall be made from material meeting the requirements of Specification [B584](#), copper alloy UNS Nos. C87710 or C87850 or Standard EN 1982, copper alloy EN Symbol CuSn4Zn6Pb3-C.

5.1.2 *Machined Copper Alloy*—Machined Copper Alloy fittings shall be made from material meeting the requirements one of the following:

³ Available from American Society of Mechanical Engineers (ASME), ASME International Headquarters, Two Park Ave., New York, NY 10016-5990, <http://www.asme.org>.

⁴ Available from American Society of Mechanical Engineers (ASME), ASME International Headquarters, Two Park Ave., New York, NY 10016-5990, <http://www.asme.org>.

⁴ Available from Manufacturers Standardization Society of the Valve and Fittings Industry (MSS), 127 Park St., NE, Vienna, VA 22180-4602, <http://www.mss-hq.org>.

⁵ Available from NSF International, P.O. Box 130140, 789 N. Dixboro Rd., Ann Arbor, MI 48105, <http://www.nsf.org>.

⁶ Available from European Committee for Standardization (CEN), Avenue Marnix 17, B-1000, Brussels, Belgium, <http://www.cen.eu>.

Specification
 B16/B16M
 B124/B124M
 B371/B371M

Aloy Designation
 UNS C36000
 UNS C65680, C87700
 UNS C69300, UNS 69850

5.1.3 *Forged Copper Alloy*—Forged Copper Alloy fittings shall be made from material meeting the requirements of Specification B283/B283M, Copper Alloy UNS Nos. C37700, C65680, C69300, C69850, or C87700.

5.2 *Press Sleeves*—Press sleeves shall be made from Specification A269/A269M UNS S30400 or S31600 and have an allowable hardness of 130 ± 20 HV5 according to Test Method E92.

5.3 *Potable Water Requirements*—Products intended for the transport of potable water shall be evaluated, tested and certified for conformance with NSF/ANSI Standard 61 or the health effects portion of NSF/ANSI Standard 14 by an acceptable certifying organization when required by the regulatory authority having jurisdiction.

5.3.1 NSF/ANSI Standard 372, limiting lead content of a water contacting component to ≤ 0.25 %, is a mandatory requirement within the current version of NSF/ANSI Standard 61.

NOTE 1—Not all alloys listed in 5.1 are NSF/ANSI 61 or NSF 372 compliant.

5.3.2 *Corrosion Resistance*—Fittings intended for potable water applications shall comply with dezincification resistance and stress corrosion cracking resistance requirements of NSF/ANSI Standard 14.

6. Requirements

6.1 *General*—All performance tests shall be performed on assemblies of fittings, press sleeves, and PEX or PE-RT tubing. Fittings and press sleeves shall meet the material and dimensional requirements of this specification. PEX tubing shall meet the requirements of Specification F876 or F3253 and PE-RT tubing shall meet the requirements of Specification F2769. Use separate sets of assemblies for each performance test requirement.

6.1.1 Fittings manufactured according to this specification for use with PEX tubing shall comply with Specification F877 Requirements, Test Methods, and Retest and Rejection. Fittings manufactured according to this specification for use with PE-RT tubing shall comply with Specification F2769; Requirements, Test Methods, and Retest and Rejection.

6.2 *Dimensions*—The dimensions and tolerances of fittings and press sleeves shall be in accordance with Table 1 as shown in Fig. 1, and Table 2 as shown in Fig. 2 when measured in accordance with 6.2.1.

6.2.1 *Measurements*—Any randomly selected fitting or fittings, and press sleeve or press sleeves, shall be used to determine dimensions. Measurements shall be made in accordance with Test Method D2122, except when measuring diameters of the after pressed sleeves, which shall be measured perpendicular to the jaw closure plane as shown in Fig. 4 and shall be in accordance with Table 3.

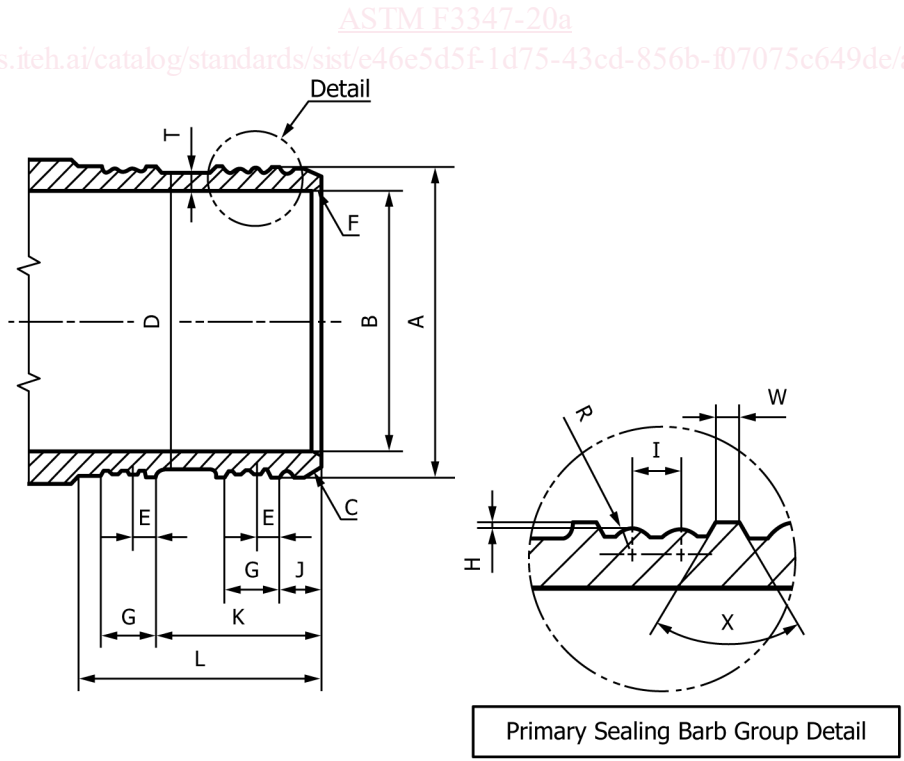

FIG. 1 Metal Insert Dimensions

TABLE 1 Metal Insert Dimensions and Tolerances

NST	A ^A	±	B ^B	±	C ^D	D	±	F	J	±	E	±	G	±
	in.	in.	in.	in.	Deg.	in.	in.	Deg.	in.	in.	in.	in.	in.	in.
5/16	0.281	0.002	0.169	0.004	20° – 30°	0.256	0.002	20° – 30°	0.091	0.004	0.049	0.004	0.118	0.004
3/8	0.344	0.002	0.236	0.004	20° – 30°	0.319	0.002	20° – 30°	0.091	0.004	0.049	0.004	0.118	0.004
1/2	0.473	0.002	0.362	0.004	20° – 30°	0.448	0.002	20° – 30°	0.091	0.004	0.049	0.004	0.118	0.004
5/8	0.571	0.002	0.457	0.004	20° – 30°	0.545	0.002	20° – 30°	0.091	0.004	0.049	0.004	0.118	0.004
3/4	0.667	0.003	0.559	0.004	20° – 30°	0.642	0.003	20° – 30°	0.091	0.004	0.049	0.004	0.118	0.004
1	0.858	0.003	0.728	0.006	20° – 30°	0.831	0.003	20° – 30°	0.091	0.004	0.049	0.004	0.118	0.004
1 1/4	1.047	0.004	0.906	0.008	20° – 30°	1.020	0.004	20° – 30°	0.110	0.004	0.059	0.004	0.138	0.004
1 1/2	1.220	0.004	1.083	0.008	20° – 30°	1.193	0.004	20° – 30°	0.110	0.004	0.059	0.004	0.138	0.004
2	1.608	0.004	1.417	0.012	20° – 30°	1.581	0.004	20° – 30°	0.189	0.004	0.059	0.004	0.138	0.004

NST	K	±	L ^C	±	W	±	I	±	T ^B	H	±	R	±	X
	in.	in.	in.	in.	in.	in.	in.	in.	min in.	in.	in.	in.	in.	Deg.
5/16	0.358	0.008	0.50	±0.01	0.020	0.004	0.039	0.004	0.040	0.005	0.001	0.020	0.004	55° – 65°
3/8	0.358	0.008	0.50	±0.01	0.020	0.004	0.039	0.004	0.038	0.005	0.001	0.020	0.004	55° – 65°
1/2	0.358	0.008	0.50	±0.01	0.020	0.004	0.039	0.004	0.040	0.005	0.001	0.020	0.004	55° – 65°
5/8	0.358	0.008	0.50	±0.01	0.020	0.004	0.039	0.004	0.041	0.005	0.001	0.020	0.004	55° – 65°
3/4	0.358	0.008	0.50	±0.01	0.020	0.004	0.039	0.004	0.038	0.005	0.001	0.020	0.004	55° – 65°
1	0.480	0.008	0.62	±0.01	0.020	0.004	0.039	0.004	0.047	0.006	0.001	0.020	0.004	55° – 65°
1 1/4	0.689	0.008	0.87	±0.01	0.020	0.004	0.039	0.004	0.065	0.006	0.001	0.020	0.004	55° – 65°
1 1/2	0.689	0.008	0.87	±0.01	0.020	0.004	0.039	0.004	0.049	0.006	0.001	0.020	0.004	55° – 65°
2	0.768	0.008	1.04	±0.01	0.020	0.004	0.039	0.004	0.074	0.006	0.001	0.020	0.004	55° – 65°

^A Rib outside diameter shall be measured individually.

^B ID "B" shall be maintained through the insert length "L".

^C Directional fittings shall be designed with sufficient overall dimensions to allow for proper alignment of press tool without interfering with the adjacent press sleeve assembly.

^D Lead chamfer area is not considered a rib.

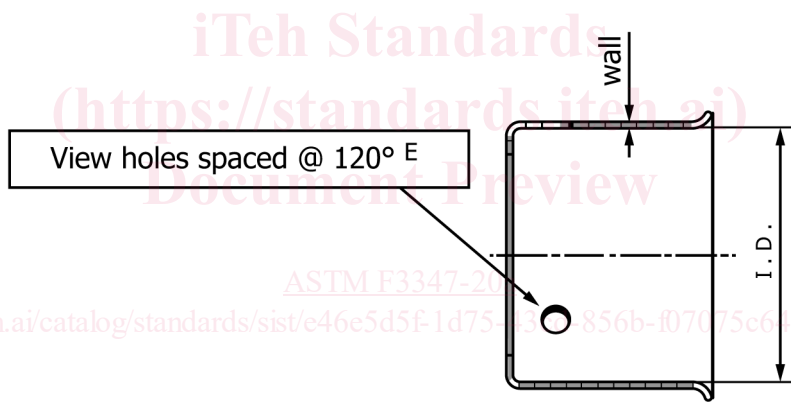

^E The three view holes' diameter and location per the fitting manufacturer's specifications.

FIG. 2 Un-Pressed Stainless Steel Sleeve Dimensions

6.2.2 *Directional Fitting Outlet(s) Angular Alignment*—The maximum angular variation of any outlet shall not exceed 1° off the true centerline axis of any adjacent outlet.

6.2.3 *Press Fittings with Solder Joint Ends*—Solder joint ends shall be in accordance with ASME B16.18 ASME B16.22, or MSS SP-104.

6.2.4 *Press Fittings with Tapered Threaded Ends*—Fitting threads shall be right-hand conforming to ASME B1.20.1. They shall be taper threads (NPT).

6.3 *Factory Assembled Press Sleeves*—Stainless steel press sleeves shall be assembled by the fitting manufacturer. Fitting design shall allow for either permanently attached (non-removable) press sleeves or snap-in-place (removable) press sleeves.

6.4 *Pressing Tool Locating Feature*—The fitting design shall provide a lateral positioning feature for the pressing tool in order to accurately locate the tool's pressing profile over the press sleeve to align the press bands directly over the centerline of their respective primary sealing barb groups. After pressing, the resulting pressing bands shall be centered over each of their respective primary sealing barb groups within the allowed offset dimension "M" given in Table 3. See Fig. 3.

6.4.1 *Pressing Profile Location and Alignment*—Compliance with 6.4 will require either machining a cross-section of a completed press assembly and taking direct measurements or by taking depth measurements from the front face of the press sleeve to the end of the insert barb and to the middle of each pressing band width (PBW). See Fig. 3.