



Designation: **F1249 – 13 F1249 – 20**

Standard Test Method for Water Vapor Transmission Rate Through Plastic Film and Sheeting Using a Modulated Infrared Sensor¹

This standard is issued under the fixed designation F1249; the number immediately following the designation indicates the year of original adoption or, in the case of revision, the year of last revision. A number in parentheses indicates the year of last reapproval. A superscript epsilon (ϵ) indicates an editorial change since the last revision or reapproval.

1. Scope

1.1 This test method covers a procedure for determining the rate of water vapor transmission through flexible barrier materials. The method is applicable to sheets and films up to 3 mm (0.1 in.) in thickness, consisting of single or multilayer synthetic or natural polymers and foils, including coated materials. It provides for the determination of (1) water vapor transmission rate (WVTR), (2) the permeance of the film to water vapor, and (3) for homogeneous materials, water vapor permeability coefficient.

NOTE 1—Values for water vapor permeance and water vapor permeability must be used with caution. The inverse relationship of WVTR to thickness and the direct relationship of WVTR to the partial pressure differential of water vapor may not always apply.

1.2 *This standard does not purport to address all of the safety concerns, if any, associated with its use. It is the responsibility of the user of this standard to establish appropriate safety, health, and environmental practices and determine the applicability of regulatory limitations prior to use.*

1.3 *This international standard was developed in accordance with internationally recognized principles on standardization established in the Decision on Principles for the Development of International Standards, Guides and Recommendations issued by the World Trade Organization Technical Barriers to Trade (TBT) Committee.*

2. Referenced Documents

2.1 ASTM Standards:²

~~D374 Test Methods for Thickness of Solid Electrical Insulation (Metric) D0374_D0374M~~

~~D1898 Practice for Sampling of Plastics (Withdrawn 1998)~~³

E96/E96M Test Methods for Water Vapor Transmission of Materials

E104 Practice for Maintaining Constant Relative Humidity by Means of Aqueous Solutions

E177 Practice for Use of the Terms Precision and Bias in ASTM Test Methods

E178 Practice for Dealing With Outlying Observations

E691 Practice for Conducting an Interlaboratory Study to Determine the Precision of a Test Method

3. Terminology

3.1 Definitions:

3.1.1 *water vapor permeability coefficient*—the product of the permeance and the thickness of the film. The permeability is meaningful only for homogeneous materials, in which case it is a property characteristic of bulk material.

¹ This test method is under the jurisdiction of ASTM Committee F02 on Flexible Primary Barrier Packaging and is the direct responsibility of Subcommittee F02.10 on Permeation.

Current edition approved Oct. 1, 2013; June 1, 2020. Published November 2013; July 2020. Originally approved in 1989. Last previous edition approved in 2013 as F1249 – 06 (2011); F1249 – 13. DOI: 10.1520/F1249-13; 10.1520/F1249-20.

² For referenced ASTM standards, visit the ASTM website, www.astm.org, or contact ASTM Customer Service at service@astm.org. For *Annual Book of ASTM Standards* volume information, refer to the standard's Document Summary page on the ASTM website.

3.1.1.1 *Discussion*—

This quantity should not be used unless the relationship between thickness and permeance has been verified in tests using several thicknesses of the material. An accepted unit of permeability is the metric perm centimeter, or $1 \text{ g}/\text{m}(\text{g}\cdot\text{cm})/(\text{m}^2 \text{ per day per mm Hg}\cdot\text{cm of thickness}\cdot\text{day}\cdot\text{mmHg})$. The SI unit is the $\text{mol}/\text{m}(\text{mol}\cdot\text{mm})/(\text{m}^2 \cdot \text{s}\cdot\text{Pa}\cdot\text{mm}\cdot\text{s}\cdot\text{Pa})$. The test conditions (see 3.1) must be stated.

3.1.2 *water vapor permeance*—the ratio of a barrier's WVTR to the vapor pressure difference between the two surfaces.

3.1.2.1 Discussion—

An accepted unit of permeance is the metric perm, or $1 \text{ g/mg}/(\text{m}^2 \text{ per day per mm Hg} \cdot \text{day} \cdot \text{mmHg})$. The SI unit is the $\text{mol/mmol}/(\text{m}^2 \cdot \text{s} \cdot \text{Pa} \cdot \text{s} \cdot \text{Pa})$. Since the permeance of a specimen is generally a function of relative humidity and temperature, the test conditions must be stated.

3.1.3 water vapor transmission rate (WVTR)—the time rate of water vapor flow normal to the surfaces, under steady-state conditions, per unit area.

3.1.3.1 Discussion—

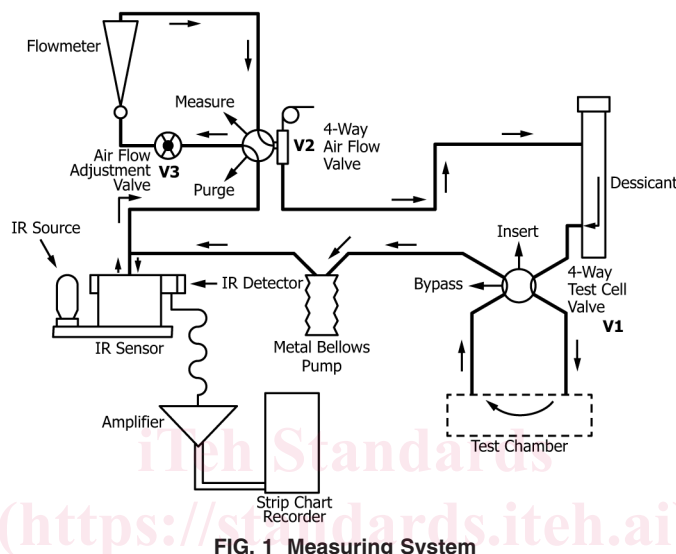

FIG. 1 Measuring System

An accepted unit of WVTR is $\text{g/mg}/(\text{m}^2 \text{ per day} \cdot \text{day})$. The test conditions of relative humidity and temperature where the humidity is the difference in relative humidity across the specimens, must be stated.

4. Summary of Test Method

4.1 A dry chamber is separated from a wet chamber of known temperature and humidity by the barrier material to be tested. The dry chamber and the wet chamber make up a diffusion cell in which the test film is sealed. Water vapor diffusing through the film mixes with the gas in the dry chamber and is carried to a pressure-modulated infrared sensor. This sensor measures the fraction of infrared energy absorbed by the water vapor and produces an electrical signal, the amplitude of which is proportional to water vapor concentration. The amplitude of the electrical signal produced by the test film is then compared to the signal produced by measurement of a calibration film of known water vapor transmission rate. This information is then used to calculate the rate at which moisture is transmitted through the material being tested.

5. Significance and Use

5.1 The purpose of this test method is to obtain reliable values for the WVTR of plastic film and sheeting.

5.2 WVTR is an important property of packaging materials and can often be directly related to shelf life and packaged product stability.

5.3 Data from this test method is suitable as a referee method of testing, provided that the purchaser and seller have agreed on sampling procedures, standardization procedures, test conditions, and acceptance criteria.

6. Apparatus

6.1 This method utilizes water vapor transmission apparatus (Fig. 1) comprised of the following:

6.1.1 Diffusion Cell—An assembly consisting of two metal halves which, when closed upon the test specimen, will accurately define a circular area. A typical acceptable diffusion cell area is 50 cm^2 . The volume enclosed by each cell half, when clamped, is not critical; it should be small enough to allow for rapid gas exchange, but not so small that an unsupported film that happens to sag or buckle will contact the top or bottom of the cell. A depth of approximately 6 mm (0.250 in.) has been found to be satisfactory for 50-cm^2 cells.

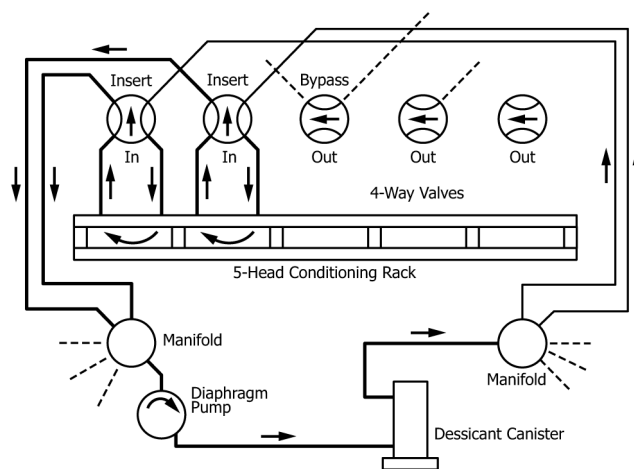

FIG. 2 Conditioning System

6.1.1.1 *Diffusion Cell O-Ring—O-Ring*—An appropriately sized groove machined into the humid chamber side of the diffusion cell retains a neoprene O-ring. The test area is considered to be the area established by the inside contact diameter of the compressed O-ring when the diffusion cell is clamped shut against the test specimen.

6.1.1.2 *Diffusion Cell Sealing Surface*—A flat rim around the dry side of the diffusion cell. This is a critical sealing surface against which the test specimen is pressed; it shall be smooth and without radial scratches.

6.1.1.3 *Diffusion Cell Air Passages*—Two holes in the dry half of the diffusion cell. This is necessary only in the earlier model WVTR instruments that have a separate conditioning rack and testing chamber. These shall incorporate O-rings suitable for sealing the diffusion cell to the test chamber pneumatic fittings for the introduction and exhaust of air without significant loss or leakage.

NOTE 2—*Use of Multiple Diffusion Cells*—Experience has shown that arrangements using multiple diffusion cells are a practical way to increase the number of measurements that can be obtained in a given time. A separate conditioning rack (Fig. 2) may be used that to start the permeation process, prior to analyzing on an instrument. A conditioning rack contains a manifold which connects the dry-chamber side of each individual diffusion cell to a dry-air source. Dry air is continually purging the dry chamber of those cells that are connected to the conditioning rack while the humid chamber side is held at a specific relative humidity by distilled water or a saturated-salt solution. It is desirable to thermostatically control the temperature of the conditioning rack as described in 6.1.3.

6.1.2 *Test Chamber*—A cavity into which the diffusion cell is inserted. Again, this is necessary only in the earlier model WVTR instruments that have a separate conditioning rack and testing chamber. The test chamber shall incorporate means for clamping the diffusion cell in accurate registration with pneumatic system openings to the dry-air source and the infrared detector. The chamber shall also provide a thermometer well for the measurement of temperature.

6.1.3 *Diffusion Cell Temperature Control*—It is desirable to thermostatically control the temperature of the diffusion cell to within $\pm 1^{\circ}\text{F}; \pm 0.6^{\circ}\text{C}$. A simple resistive heater attached to the station in such a manner as to ensure good thermal contact is adequate for this purpose. A thermistor sensor and an appropriate control circuit will serve to regulate the temperature unless measurements are being made close to ambient temperature. In that case it may be necessary to provide cooling coils to remove some of the heat.

6.1.4 *Flowmeter*—A means for regulating the flow of dry air within an operating range of 5 to 100 cc/min is required.

6.1.5 *Flow-Switching Valves*, for the switching of dry-gas flow streams of the water vapor transmission apparatus.

6.1.6 *Infrared Sensor*—A water vapor detector capable of sensing 1 $\mu\text{g/L}$ of water, or, in other terms, 1 ppm by volume, or 0.002 % relative humidity at 37.8°C.

6.1.7 *Recording Device*—A multirange strip chart recorder or other appropriate instrument for measuring the voltage developed by the signal amplifier.

6.1.8 *Desiccant Drying System*, shall be capable of reducing the concentration of water vapor in the gas source down to less than 0.5 ppm by volume or 0.001 % relative humidity at 37.8°C. In earlier model WVTR equipment, a separate desiccant drying system is needed for the conditioning rack and test chamber.

6.1.9 *Flow-Metering Valve*—A fine-metering valve capable of controlling the dry-gas flow rate to the test cell when the apparatus is in the “measure” mode of operation.

7. Reagents and Materials

7.1 *Desiccant*, for drying gas stream.

7.2 *Absorbent Pads* (not critical), such as filter pads of 30 to 75 mm in diameter. Necessary only in earlier model WVTR equipment that utilizes distilled water or saturated salt solutions to generate the desired relative humidity.

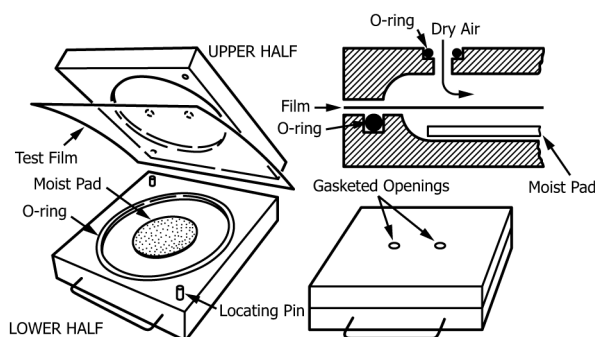

FIG. 3 Film Diffusion Cell

7.3 *Distilled Water*, for producing 100 % relative humidity, or various saturated salt solutions to produce other relative humidities as described in Practice E104. Newer WVTR equipment does not require saturated salt solutions. Refer to the manufacturer's instructions for generating relative humidity.

7.4 *Reference Film*, known WVTR material for system calibration.

7.5 *Sealing Grease*, a high-viscosity, silicone stopcock grease or other suitable high-vacuum grease is required for lubrication of O-rings and to seal the specimen film in the diffusion cell.

7.6 *Nitrogen Gas*, shall be dry and contain not less than 99.5 % nitrogen. Needed only with certain WVTR instruments.

8. Sampling

8.1 Select material and quantity for testing in accordance with standard methods of sampling applicable to the material under test. ~~Sampling may be done in accordance with Practice D1898.~~ Select samples considered representative of the material to be tested. If the material is of nonsymmetrical construction, the orientation should be noted.

9. System Calibration With Reference Film

9.1 Follow the manufacturer's instructions for calibrating the WVTR instrument with a reference film.

10. Test Procedure

10.1 *Preparation of Apparatus* (Fig. 1)—If preceding tests have exposed the apparatus to high moisture levels, outgas the system to desorb residual moisture.

10.2 *Number of Specimens Tested*—~~Test enough specimens to characterize package permeation rates but never less than three per sample.~~ specimens per agreed upon sample plan.

10.3 *Preparation of Test Samples:*

10.3.1 Cut the test specimen to approximately 10 cm by 10 cm (4 in. by 4 in.).

10.3.2 ~~Measure~~ If required, measure specimen thickness at four equally spaced points within the test area and at the center in accordance with guidelines described in Test Method center. Note: if a sample is fragile (such as ~~D374~~ a thin coating or unprotected metallization) the act of measuring the material might compromise or scratch the barrier layer. For such samples, analyzing the material thickness AFTER transmission rate testing may be preferable.

10.3.3 Lightly grease the cell sealing surface and the cell O-ring.

10.3.4 For earlier model WVTR systems that require the use of distilled water or saturated salt solutions, insert one to three absorbent pads into the lower half-cell and dampen with distilled water or a desired salt solution. Otherwise, for newer WVTR instruments, follow the manufacturer's instructions for generating the desired relative humidity.

10.3.5 Affix the test film to the diffusion cell following the manufacturer's instructions. Fig. 3 shows the type of diffusion cell used in earlier model WVTR equipment that consisted of a separate conditioning rack and testing chamber. Diffusion cells in newer WVTR equipment are similar to the lower half of the cell displayed in Fig. 3.

10.3.6 If using a separate conditioning rack, clamp the assembled cell in the conditioning rack. Allow the film to condition in the diffusion cell until steady state has been attained. If unfamiliar with the material being tested, the operator should investigate the effect of conditioning time to be certain that sufficient time has been allowed for the material to equilibrate under the test conditions (see Note 3).

10.4 Measure the WVTR of the film specimen following the manufacturer's instructions.

NOTE 3—When testing materials for which the operator has no previous history, additional time must be allowed to assure that true equilibrium has been reached. When in doubt, retest after an additional conditioning interval of several hours.

10.5 Record temperature of each test with reference to a thermometer or thermocouple installed in the test chamber thermometer well. Temperature is a critical parameter affecting the measurement of WVTR. During testing, monitor the temperature, periodically, to the nearest 0.5°C. Report the average temperature and the range of temperatures observed during the test.

10.6 *Standby and Shutoff Procedures:*

10.6.1 Follow the manufacturer's instructions for putting the instrument in standby when not being used.

10.6.2 When the system is not to be used for an extended period and there are no films that require conditioning, the electrical power may be turned off.

11. Calculation

11.1 *WVTR*—If using a recorder, calculate water vapor transmission rate using the formula:

$$WVTR = C (ES - EO)$$

where:

C = a calibration factor expressing rate as a function of voltage (or mV). The value of *C* is derived from tests of a known reference film (Section 9),

EO = permeation system zero level voltage, and

ES = equilibrium voltage obtained with the test specimen.

Newer computer-controlled systems will automatically calculate the WVTR.

11.2 *Permeance*—Calculate sample permeance (if required) using the following relationship:

$$\text{Metric Perms} = \frac{WVTR}{P_w} = \frac{\text{g/m}^2 \cdot \text{day} \cdot \text{mm Hg}}{\text{mmHg}}$$

$$\text{Metric Perms} = \frac{WVTR}{P_w} = \text{g}/(\text{m}^2 \cdot \text{day} \cdot \text{mmHg})$$

where:

WVTR = Specimen water vapor transmission rate, g/m²·d, and

WVTR = Specimen water vapor transmission rate, g/(m²·day), and

P_w = Water vapor partial pressure gradient across the test specimen, mmHg.

11.3 *Permeability Coefficient*—Calculate the water vapor permeability coefficient (if required) using the following relationship:

$$\text{Permeability} = \text{metric perms} \cdot t$$

where:

t = the average thickness of the specimen, mm. Note: Permeability calculations are meaningful only in cases where materials have been determined to be homogeneous.

12. Report

12.1 Report the following information:

12.1.1 A description of the test specimen. If the material is nonsymmetrical (two sides different), include a statement as to which side was facing the high humidity,

12.1.2 The humidity environment on each side of the test film and means by which it was obtained,

12.1.3 The test temperature (to nearest 0.5°C),

12.1.4 The values of WVTR and, if desired, required, values of thickness, permeance and permeability. These entries should be rounded off to three significant figures or less, as may be consistent with the operator's estimate of precision or bias,

12.1.5 A statement of the means used to obtain the calibration factor,

12.1.6 The effective area exposed to permeation and a description of how it was defined,

12.1.7 The time to reach steady-state after introduction of the diffusion cell into the test chamber, and

12.1.8 A description of the conditioning procedure.

13. Precision and Bias

13.1 The precision of this test method is based on an interlaboratory study of F1249, Standard Test Method for Water Vapor Transmission Rate Through Plastic Film and Sheeting Using a Modulated Infrared Sensor, conducted in 2012. Each of twelve laboratories tested seven different materials. Every "test result" represents an individual determination, and all participants reported duplicate WVTR test results. Practice E691 was followed for the design and analysis of the data; the details are given in ASTM Research Report RR: F02-1000.³

³ Supporting data have been filed at ASTM International Headquarters and may be obtained by requesting Research Report RR:F02-1000. Contact ASTM Customer Service at service@astm.org.