



Designation: **D6330 – 98 (Reapproved 2014) D6330 – 20**

## Standard Practice for Determination of Volatile Organic Compounds (Excluding Formaldehyde) Emissions from Wood-Based Panels Using Small Environmental Chambers Under Defined Test Conditions<sup>1</sup>

This standard is issued under the fixed designation D6330; the number immediately following the designation indicates the year of original adoption or, in the case of revision, the year of last revision. A number in parentheses indicates the year of last reapproval. A superscript epsilon ( $\epsilon$ ) indicates an editorial change since the last revision or reapproval.

### 1. Scope

1.1 The practice measures the volatile organic compounds (VOC), excluding formaldehyde, emitted from manufactured wood-based panels. A pre-screening analysis is used to identify the VOCs emitted from the panel. Emission factors (that is, emission rates per unit surface area) for the VOCs of interest are then determined by measuring the concentrations in a small environmental test chamber containing a specimen. The test chamber is ventilated at a constant air change rate under the standard environmental conditions. For formaldehyde determination, see Test Method [D6007](#).

1.2 This practice describes a test method that is specific to the measurement of VOC emissions from newly manufactured individual wood-based panels, such as particleboard, plywood, and oriented strand board (OSB), for the purpose of comparing the emission characteristics of different products under the standard test condition. For general guidance on conducting small environmental chamber tests, see Guide [D5116](#).

1.3 VOC concentrations in the environmental test chamber are determined by adsorption on an appropriate single adsorbent tube or multi-adsorbent tube, followed by thermal desorption and combined gas chromatograph/mass spectrometry (GC/MS)(GC-MS) or gas chromatograph/ flame ionization detection (GC/FID)(GC-FID). The air sampling procedure and the analytical method recommended in this practice are generally valid for the identification and quantification of VOCs with saturation vapor pressure between 500 and 0.01 kPa at 25°C, depending on the selection of adsorbent(s).

NOTE 1—VOCs being captured by an adsorbent tube depend on the adsorbent(s) and sampling procedure selected (see Practice [D6196](#)). The user should have a thorough understanding of the limitations of each adsorbent used. Although canisters can be used to sample VOCs, this standard is limited to sampling VOCs from the chamber air using adsorbent tubes.

1.4 The emission factors determined using the above procedure describe the emission characteristics of the specimen under the standard test condition. These data can be used directly to compare the emission characteristics of different products and to estimate the emission rates up to one month after the production. They shall not be used to predict the emission rates over longer periods of time (that is, more than one month) or under different environmental conditions.

1.5 Emission data from chamber tests can be used for predicting the impact of wood-based panels on the VOC concentrations in buildings by using an appropriate indoor air quality model, which is beyond the scope of this practice.

1.6 The values stated in SI units shall be regarded as the standard (see [IEEE/ASTM SI-10](#)).

1.7 *This standard does not purport to address all of the safety concerns, if any, associated with its use. It is the responsibility of the user of this standard to establish appropriate safety, health, and environmental practices and determine the applicability of regulatory limitations prior to use.* For specified hazard statements see Section 6.

1.8 *This international standard was developed in accordance with internationally recognized principles on standardization established in the Decision on Principles for the Development of International Standards, Guides and Recommendations issued by the World Trade Organization Technical Barriers to Trade (TBT) Committee.*

<sup>1</sup> This practice is under the jurisdiction of ASTM Committee [D22](#) on Air Quality and is the direct responsibility of Subcommittee [D22.05](#) on Indoor Air. Current edition approved Nov. 1, 2014/March 1, 2020. Published November 2014/May 2020. Originally approved in 1998. Last previous edition approved in 2008/2014 as [D6330 – 98 \(2008\)](#); (2014). DOI: [10.1520/D6330-98R14](#); [10.1520/D6330-20](#).

## 2. Referenced Documents

### 2.1 ASTM Standards:<sup>2</sup>

[D1356 Terminology Relating to Sampling and Analysis of Atmospheres](#)

[D1914 Practice for Conversion Units and Factors Relating to Sampling and Analysis of Atmospheres](#)

[D5116 Guide for Small-Scale Environmental Chamber Determinations of Organic Emissions from Indoor Materials/Products](#)

[D6007 Test Method for Determining Formaldehyde Concentrations in Air from Wood Products Using a Small-Scale Chamber](#)

[D6196 Practice for Choosing Sorbents, Sampling Parameters and Thermal Desorption Analytical Conditions for Monitoring](#)

[Volatile Organic Chemicals in Air](#)

[E355 Practice for Gas Chromatography Terms and Relationships](#)

[E741 Test Method for Determining Air Change in a Single Zone by Means of a Tracer Gas Dilution](#)

[IEEE/ASTM SI-10 Standard for Use of the International System of Units \(SI\): The Modern Metric System](#)

### 2.2 Other Standard:

[EPA TO-17 Determination of Volatile Organic Compounds in Ambient Air Using Active Sampling Onto Sorbent Tubes, Compendium of Methods for the Determination of Toxic Organic Compounds in Ambient Air](#)

[ISO 17025:2017 General Requirements for the Competence of Testing and Calibration Laboratories](#)

## 3. Terminology

3.1 *Definitions*—For definitions and terms that are commonly used, refer to Terminology [D1356](#) and Practice [E355](#). For definitions and terms related to test methods using small-scale environmental chamber, refer to Guide [D5116](#). For an explanation of units, symbols, and conversion factors, refer to Practice [D1914](#).

### 3.2 Definitions of Terms Specific to This Standard:

3.2.1 *environmental enclosure*—*enclosure, n*—a container or space in which the environmental test chamber(s) is placed. The enclosure has controlled temperature and relative humidity.

3.2.2 *loading ratio (m<sup>2</sup>/m<sup>3</sup>)*—*n*—the total exposed surface area of each test specimen divided by the net air volume of the environmental test chamber.

3.2.3 *nominal time constant (t<sub>n</sub>)*—*n*—the time required to obtain one air change in the environmental test chamber, which is equal to the inverse of the air change rate.

3.2.4 *pre-screening analysis*—*analysis, n*—a procedure for identifying the VOCs emitted from a test specimen. The results are used to determine the appropriate [GC/MSGC-MS](#) or [GC/FIDGC-FID](#) analytical method for subsequent dynamic chamber tests.

3.2.5 *standard environmental test chamber condition*—*condition, n*—a test condition of temperature at 23 ± 0.5°C, relative humidity (RH) at 50 ± 5 %, air change rate per hour in the chamber at 1 ± 0.03 ACH, and chamber loading ratio at 0.40 ± 0.01 m<sup>2</sup>/m<sup>3</sup>.

[ASTM D6330-20](#)

<https://standards.iteh.ai/catalog/standards/sist/023ed9d-5799-4161-8cff-cf042bc570a8/astm-d6330-20>

#### 3.2.5.1 Discussion—

The VOC emission rates for wood-based panel products are generally controlled by VOC diffusions within the material. The airflow condition (air velocity and turbulence) over the test specimen has minimal effect on the emission rates; therefore, it is not specified in the standard test condition.

3.2.6 *tracer gas*—*gas, n*—a gaseous compound that is neither emitted by the wood-based panel nor present in the supply air to the chamber. It can be used to determine the mixing characteristics of the environmental test chamber, and it provides a cross-check of the air change rate measurements.

3.2.7 *TVOC*—total concentration of all the individual volatile organic compounds (VOC) captured from air by a given sorbent, or a given combination of several sorbents, thermally desorbed into and eluted from a given gas chromatographic system and measured by a given detector. For VOC definition, see Terminology [D1356](#).

#### 3.2.7.1 Discussion—

The measured value of TVOC will depend on the collection and desorption efficiency of the sorbent trap, the efficiency of transfer to the GC column, the type and size of the GC column, the GC temperature program and other chromatographic parameters, and the type of GC detector. One way to report TVOC values is recommended in [8.2.7.6](#).

3.2.7 *wood-based panel test specimen*—*specimen, n*—a specimen of a panel cut from an original wood-based panel sample, such as particleboard, oriented strand board (OSB), or plywood.

<sup>2</sup> For referenced ASTM standards, visit the ASTM website, [www.astm.org](http://www.astm.org), or contact ASTM Customer Service at [service@astm.org](mailto:service@astm.org). For *Annual Book of ASTM Standards* volume information, refer to the standard's Document Summary page on the ASTM website.

#### 4. Significance and Use

4.1 The effects of VOC sources on the indoor air quality in buildings have not been well established. One basic requirement that has emerged from indoor air quality studies is the need for well-characterized test data on the emission factors of VOCs from building materials. Standard test method and procedure are a requirement for the comparison of emission factor data from different products.

4.2 This practice describes a procedure for using a small environmental test chamber to determine the emission factors of VOCs from wood-based panels over a specified period of time. A pre-screening analysis procedure is also provided to identify the VOCs emitted from the products, to determine the appropriate GC/MSGC-MS or GC/FIDGC-FID analytical procedure, and to estimate required sampling volume for the subsequent environmental chamber testing.

4.3 Test results obtained using this practice provide a basis for comparing the VOC emission characteristics of different wood-based panel products. The emission data can be used to inform manufacturers of the VOC emissions from their products. The data can also be used to identify building materials with reduced VOC emissions over the time interval of the test.

4.4 While emission factors determined by using this practice can be used to compare different products, the concentrations measured in the chamber shall not be considered as the resultant concentrations in an actual indoor environment.

#### 5. Apparatus

5.1 This practice requires the use of an environmental chamber test system, an air sample collection system, and a chemical analysis system. A general guide for conducting small environmental chamber tests is provided in Guide **D5116**. The following paragraphs describe the requirements that are specific to this practice:

5.2 *Environmental Chamber Testing System*—The system shall include an environmental test chamber, an environmental enclosure, equipment for supplying clean and conditioned air to the chamber, and outlet fittings for sampling the air exhausted from the chamber. **Fig. 1** illustrates an example of such systems. All materials and components in contact with panel specimen or air stream from the chamber inlet to sample collection point shall be chemically inert and accessible for cleaning. Suitable materials include stainless steel and glass. All gaskets and flexible components shall be made from chemically inert materials.

5.2.1 *Environmental Test Chamber*—The chamber should have a volume of 0.05 m<sup>3</sup> with the interior dimensions of 0.5 m by 0.4 m by 0.25 m to 0.25 m high. A chamber with a different size and shape may also be used if the same standard environmental test chamber conditions (see 3.2.5) can be maintained. The chamber shall include a supply air system having an inlet port with distributed openings to assist mixing between the supply air and chamber air and an outlet port with distributed exhaust openings to ensure that concentration measured at the chamber exhaust is the average concentration in the chamber. The chamber criteria are as follows:

5.2.1.1 *Air-Tightness of the Chamber*—The nominal air leakage rate of the chamber shall be less than 1 % of the air change rate used for the emission test at 10 Pa. Air-tightness is measured as follows: (1) seal the outlet of the chamber; (2) supply air to the chamber through the inlet and adjust the airflow rate so that the pressure difference between the inside and outside of the chamber is maintained at 10 ± 1 Pa, which is measured by a pressure transducer with a minimum specified accuracy of ±1 Pa; and (3) measure the airflow rate. The rate is the nominal leakage rate of the chamber.

5.2.1.2 *Air Mixing in the Chamber*—Adequate air mixing in the chamber shall be achieved to ensure that concentrations measured at the chamber exhaust are representative of those in the chamber. This may be determined by using the following tracer gas decay method: (1) place a small mixing fan (for example, a personal computer cooling fan) in the chamber; (2) operate the chamber under the standard test condition and turn on the mixing fan; (3) inject a small amount (a pulse) of an inert tracer gas into the chamber directly or by means of the supply air; (4) allow 5 min for the gas to mix with the chamber air; (5) turn off the mixing fan and record the time as  $t = 0$ ; and (6) measure the concentrations of the tracer gas at the exhaust of the chamber at the following time points:  $t = 0, 0.25 t_n, 0.5 t_n, 1.0 t_n, 1.5 t_n,$  and  $2.0 t_n$ , where  $t_n$  is the nominal time constant and is equal to 1.0 h for the standard test condition. The measured concentrations are compared to the values given by the following theoretical equation under the perfect mixing condition (in which the concentrations measured at the exhaust are the same as those in the chamber):

$$C_{(t)} = C_0 e^{-Nt} \quad (1)$$

$$C(t) = C_0 e^{-Nt} \quad (1)$$

where:

$C_0$  = initial concentration at  $t=0$ ,  $\mu\text{g}/\text{m}^3$ ,

$C_0$  = initial concentration at  $t = 0$ ,  $\mu\text{g}/\text{m}^3$ ,

$C_{(t)}$  = concentration at time  $t$ ,  $\mu\text{g}/\text{m}^3$ ,

$C(t)$  = concentration at time  $t$ ,  $\mu\text{g}/\text{m}^3$ ,

$N$  = air change rate,  $\text{h}^{-1}$ , and

$N$  = air change rate, 1/h, and

$t$  = time from the start of the air purging, h.

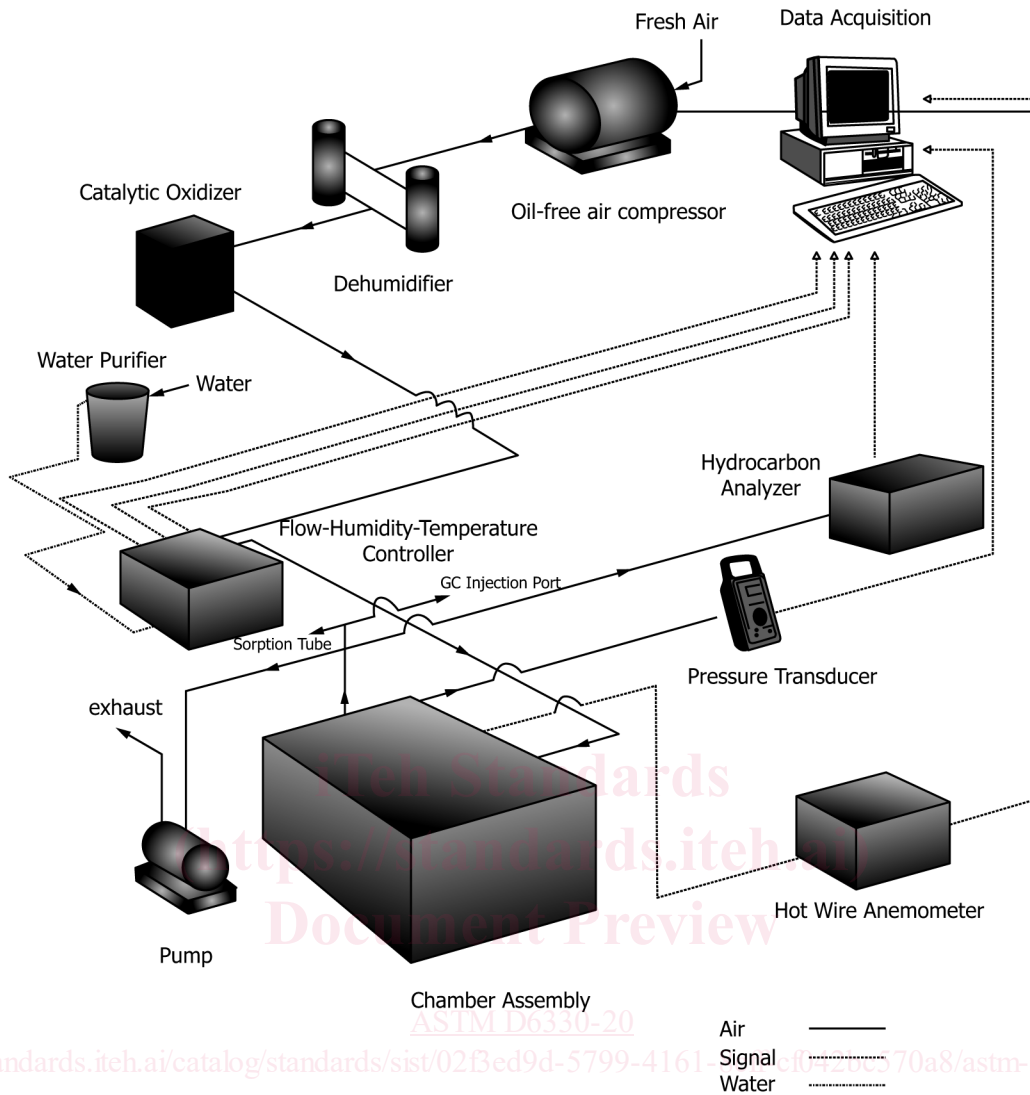

NOTE 1—The chamber assembly should be contained in an environmental enclosure to maintain the required temperature.

FIG. 1 Schematic of an Example Small Chamber Test System

The maximum difference between the measured and calculated theoretical values shall be within  $\pm 5\%$  of the theoretical value. The above mixing test shall be conducted with a simulated test specimen placed in the chamber.

NOTE 2—The above test method is a simplified version of the decay method described in Guide D5116. Alternatively, the method of determining adequate air mixing described in Guide D5116 may also be used to check the mixing condition in the chamber.

5.2.1.3 *Sample Specimen Holder*—A sample specimen holder shall be used to hold the test specimen so that only the test surface of the specimen is exposed to the chamber air. The holder shall be designed to minimize the emissions from edges and non-testing surface of the specimen. A design example is shown in Fig. 2.

5.2.1.4 *Sink Effect*—The chamber and specimen holder shall have minimum sink effect. The recovery factor determined by the following procedure shall be higher than 95% for decane: (1) seal the supply inlet and exhaust of the chamber; (2) inject  $5\ \mu\text{g}$  of vaporized decane into the chamber; (3) take an air sample from the chamber exhaust at 5 min after the injection, and record this concentration as the initial concentration  $C_0$  and the time as  $t = 0$ ; (4) at  $t = 0$ , begin purging the air through the chamber at  $t = 0$  under standard test conditions; (5) take air samples from the chamber exhaust at the following times after the start of purging:  $t_1 = 0.25 t_n$ ,  $t_2 = 0.5 t_n$ ,  $t_3 = 1.0 t_n$ ,  $t_4 = 1.5 t_n$ ,  $t_5 = 2.0 t_n$ ,  $t_6 = 3.0 t_n$ ,  $t_7 = 4.5 t_n$ ,  $t_8 = 6 t_n$ ,  $t_9 = 8 t_n$ , and  $t_{10} = 10 t_n$ , where  $t_n$  is the nominal time constant and is equal to 1.0 h for the standard test condition; and (6) calculate the recovery factor (RF) as follows:

$$RF = \frac{N}{2C_0} \sum_{i=0}^{n-1} [C(t_i) + C(t_{i+1})](t_{i+1} - t_i) 100\% \quad (2)$$

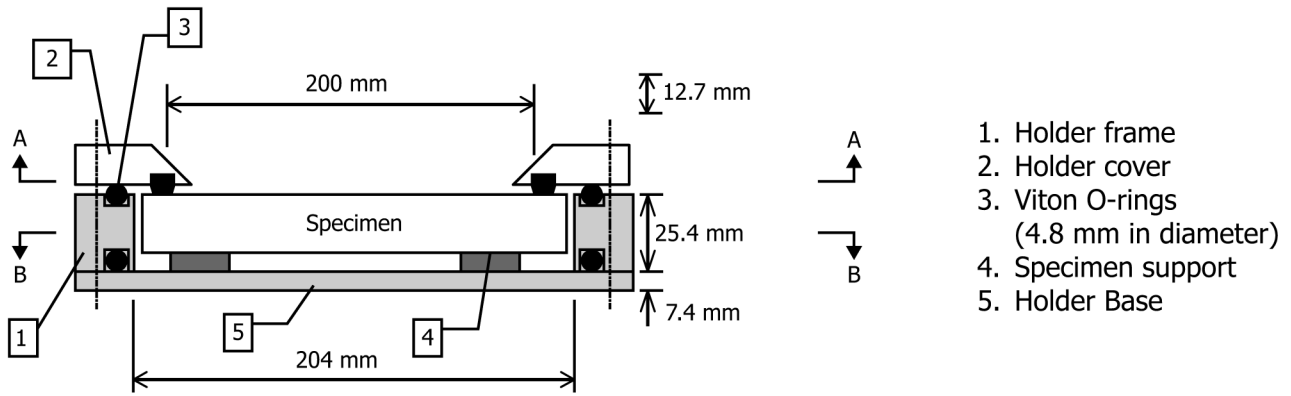

1. Holder frame
2. Holder cover
3. Viton O-rings (4.8 mm in diameter)
4. Specimen support
5. Holder Base

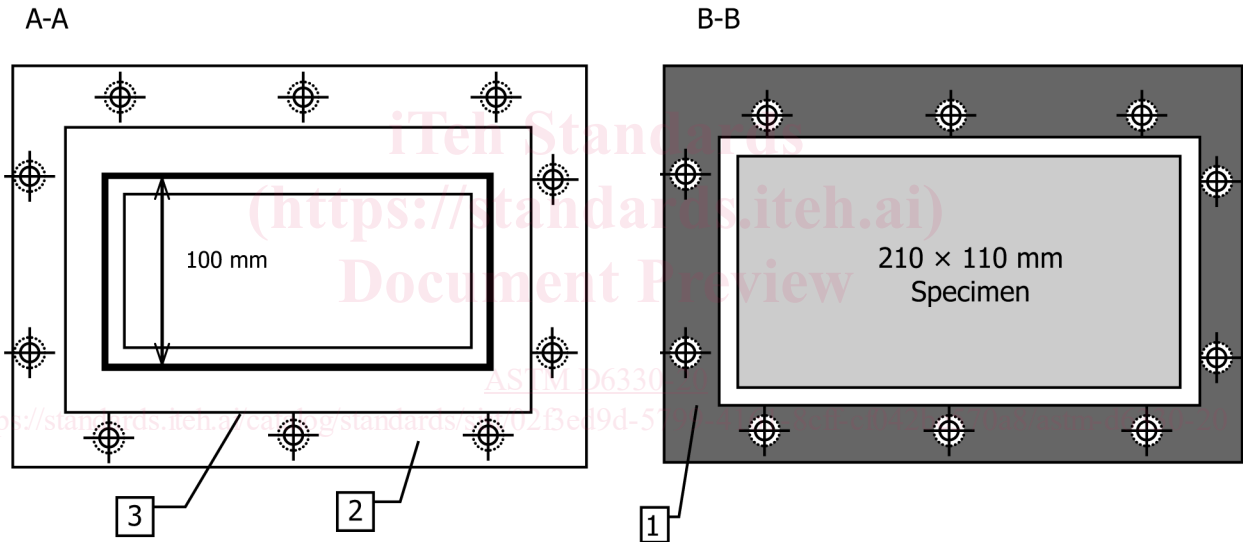

NOTE 1—All materials for the sample holder should be made of electropolished stainless steel.

FIG. 2 Schematic of an Example Sample Holder

where:

- $RF$  = recovery factor, %
- $N$  = air change rate,  $h^{-1}$
- $\bar{N}$  = air change rate, 1/h
- $C_0$  = initial concentration at  $t=0$ ,  $\mu g/m^3$
- $C_a$  = initial concentration at  $t = 0$ ,  $\mu g/m^3$
- $C(t_i)$  = concentration at time  $t_i$ ,  $\mu g/m^3$  ( $i=0, 1, 2, \dots, 10$ ), and
- $C(t_i)$  = concentration at time  $t_i$ ,  $\mu g/m^3$  ( $i = 0, 1, 2, \dots, 10$ ), and
- $t_i$  = time from the start of the air purging, h.

The above sink effect test should be conducted after the mixing condition in the chamber has been verified (see 5.2.1.2).

NOTE 3—The concentration decay is usually close to the first-order exponential decay curve (that is,  $C(t)/C_0 = e^{-Nt}$ ). The above sampling time intervals are chosen such that the amount of concentration decrease during each sampling interval will be similar.

5.2.1.5 The environmental test chamber shall be contained in an environmental enclosure (see 5.2.2).



5.2.1.6 The background concentration of the environmental test chamber is measured at the chamber exhaust. The background concentration shall meet the following criteria: (1)  $20 \mu\text{g}/\text{m}^3$  or  $1/6$  of the lowest concentration to be measured, whichever is lower, for ~~TVOC~~, TVOC (total volatile organic compounds), and (2)  $1 \mu\text{g}/\text{m}^3$  or  $1/6$  of the lowest concentrations to be measured, whichever is lower, for individual VOCs.

NOTE 4—Conventionally, the minimum quantifiable concentration is determined by:

$$C_{min} = c + 10 s \quad (3)$$

where:

$C_{min}$  = the minimum quantifiable concentration,  
 $c$  = the mean background concentration, and  
 $s$  = the standard deviation of the background concentration during the test period.

For simplicity, it may be assumed that  $s = 0.5 c$ . As a result,  $C_{min} = 6 c$ .

NOTE 5—The  $20 \mu\text{g}/\text{m}^3$  limit set for TVOC in chamber air is the minimum level of cleanliness that a test chamber system shall have.

5.2.2 *Environmental Enclosure*—The enclosure is the surrounding environment of the test chamber that can maintain the temperature at  $23.0 \pm 0.5^\circ\text{C}$  and relative humidity at  $50 \pm 5\%$  RH during the period of loading the test specimen, and maintain the temperature at  $23.0 \pm 0.5^\circ\text{C}$  during the entire testing period. Once the chamber door is closed, the relative humidity in the chamber is maintained by the air supply to the chamber. A temperature ( $23.0 \pm 0.5^\circ\text{C}$ ) and humidity ( $50 \pm 5\%$  RH) controlled room is found to be adequate for this purpose. Otherwise, a stand-alone structure has to be built as the environmental enclosure.

5.2.3 *Clean Air Supply System*—The system shall be capable of supplying a controlled flow of clean air into the test chamber. Concentrations measured at the chamber inlet shall meet the following criteria at an airflow rate  $\geq 1.0 \geq 1.0$  chamber volume per hour:

~~TVOC (as defined in 5.4.5.4) concentration  $\leq 10 \mu\text{g}/\text{m}^3$ ,  
 TVOC (as defined in 5.4.5.4) concentration  $\leq 10 \mu\text{g}/\text{m}^3$ ,  
 Concentration of any individual VOC  $\leq 0.5 \mu\text{g}/\text{m}^3$ ,  
 Particulate concentration  $\leq 100$  particles/ $\text{m}^3$  of  $0.5\text{-}\mu\text{m}$  diameter or larger, and  
 Ozone concentration  $\leq 3 \mu\text{g}/\text{m}^3$ .~~

~~Concentration of any individual VOC  $\leq 0.5 \mu\text{g}/\text{m}^3$ ,  
 Particulate concentration  $\leq 100$  particles/ $\text{m}^3$  of  $0.5\text{-}\mu\text{m}$  diameter or larger, and  
 Ozone concentration  $\leq 3 \mu\text{g}/\text{m}^3$ .~~

A typical clean air supply system should include the following components (see Fig. 1):

5.2.3.1 An air pump(s) or an oil-free compressor capable of supplying air at a rate of 1.0 chamber volume per hour. A particulate filter shall be installed on the air intake.

5.2.3.2 A dehumidifier (for example, a desiccant drier) capable of keeping the relative humidity below 45 % RH.

5.2.3.3 A catalytic oxidizer or equivalent air purifier (for example, activated carbon filter) capable of removing organic compounds so that the concentrations of TVOC and any individual VOCs are below  $10 \mu\text{g}/\text{m}^3$  and  $0.5 \mu\text{g}/\text{m}^3$ , respectively.

5.2.3.4 An air conditioning device and an airflow controller capable of controlling the airflow rate, temperature, and relative humidity of the supply air at  $1.0 \pm 0.03$  ACH,  $23.0 \pm 0.5^\circ\text{C}$  and  $50 \pm 5\%$  RH, respectively. Deionized water (or equivalent) shall be used in the humidification.

5.2.3.5 An exhaust air pump and an airflow controller for controlling the pressure in the chamber. The airflow controller shall be adjusted so that the air pressure in the chamber will be positive relative to air pressure outside the chamber despite the fluctuations in the ambient air pressure. A typical pressure to be maintained in the chamber is  $10 \pm 5$  Pa relative to the ambient pressure outside of the chamber.

5.2.3.6 Sensors and a recording system for monitoring airflow rate, temperature, relative humidity, and pressure inside the environmental test chamber.

5.3 *Air Sampling System*—The system shall include an adsorbent tube, a mechanical pump, and an airflow controller, which can measure and control the airflow rate through the sampling system to within  $\pm 5\%$  of a specified value. All system components between the chamber and the adsorbent tube shall be constructed of chemically inert materials.

5.3.1 The adsorbent tube should be connected as close to the chamber exhaust as possible by using a short ( $<0.15$  m from the environmental enclosure) stainless steel or PTFE tube/connector. The pump shall be operated in vacuum mode downstream of the adsorbent tube to avoid contamination of air samples by the pump.

5.3.2 For effective collections of VOCs in the exhaust air of the test chamber, an appropriate single or multi-layered adsorbent tube should be used depending on the VOCs to be measured.

5.3.3 Sampling of the exhaust air shall not affect the control of airflow rate to the test chamber. The airflow controller for the exhaust air pump shall be adjusted before air sampling so that the air pressure in the chamber will remain positive during the sample collection period. A sampling flow rate of less than one third of the total supply airflow rate to the test chamber is recommended to avoid excessive depressurization in the chamber during the sampling period. The manufacturer's recommendations for proper use of adsorbent tubes shall be followed for selecting the sampling airflow rate and for the sampling period to avoid breakthrough of VOCs. Air sample volumes (that is, sampling flow rate times the sampling period) should be determined by (1)