



Designation: **F2996—13 F2996 – 20**

Standard Practice for Finite Element Analysis (FEA) of Non-Modular Metallic Orthopaedic Hip Femoral Stems¹

This standard is issued under the fixed designation F2996; the number immediately following the designation indicates the year of original adoption or, in the case of revision, the year of last revision. A number in parentheses indicates the year of last reappraisal. A superscript epsilon (ϵ) indicates an editorial change since the last revision or reappraisal.

1. Scope

1.1 This practice establishes requirements and considerations for the numerical simulation of non-modular (that is, limited to monolithic stems with only a femoral ~~head/trunnion~~ head/trunnion taper interface) metallic orthopaedic hip stems using Finite Element Analysis (FEA) techniques for the estimation of stresses and strains. This standard is only applicable to stresses below the yield strength, as provided in the material certification.

1.2 *Purpose*—This practice establishes requirements and considerations for the development of finite element models to be used in the evaluation of non-modular metallic orthopaedic hip stem designs for the purpose of prediction of the static implant stresses and strains. This procedure can be used for ~~worst case~~ worst-case assessment within a ~~family~~ series of ~~implant sizes to provide efficiencies in the amount of physical testing to be conducted.~~ different sizes of the same implant design to reduce the physical test burden. Recommended procedures for performing model checks and verification are provided to help determine if the analysis follows recommended guidelines. Finally, the recommended content of an engineering report covering the mechanical simulation is presented.

1.3 *Limits*—This practice is limited in discussion to the static structural analysis of non-modular metallic orthopaedic hip stems (which excludes the prediction of fatigue strength).

1.4 The values stated in SI units are to be regarded as standard. No other units of measurement are included in this standard.

1.5 *This standard does not purport to address all of the safety concerns, if any, associated with its use. It is the responsibility of the user of this standard to establish appropriate safety, health, and environmental practices and determine the applicability of regulatory limitations prior to use.*

1.6 *This international standard was developed in accordance with internationally recognized principles on standardization established in the Decision on Principles for the Development of International Standards, Guides and Recommendations issued by the World Trade Organization Technical Barriers to Trade (TBT) Committee.*

2. Referenced Documents

2.1 ISO Standards:²

ISO 7206-4 (2010) Implants for Surgery—Partial and Total Hip Joint Prostheses—Part 4: Determination of Endurance Properties and Performance of Stemmed Femoral Components

¹ This practice is under the jurisdiction of ASTM Committee F04 on Medical and Surgical Materials and Devices and is the direct responsibility of Subcommittee F04.22 on Arthroplasty.

Current edition approved July 15, 2013; June 15, 2020. Published August 2013; August 2020. Originally approved in 2013. Last previous edition approved in 2013 as F2996 – 13. DOI: [10.1520/F2996-13](https://doi.org/10.1520/F2996-13), [10.1520/F2996-20](https://doi.org/10.1520/F2996-20).

² Available from International Organization for Standardization (ISO), 1, ch. de la Voie-Creuse, CP 56, CH-1211 Geneva 20, Switzerland, <http://www.iso.org>.

3. Significance and Use

3.1 This practice is applicable to the calculation of stresses seen on a femoral hip stem when loaded in a manner described in ISO 7206-4 (2010). This method can be used to establish the ~~worst case~~ worst-case size for a particular implant. When stresses calculated using this practice were compared to the stresses measured from physical strain gauging techniques performed at two laboratories using two different methods, the results correlated to within 8 %.

3.2 This test method can be used to estimate the effects of design variables on the stress and strain of metallic hip femoral stems in a set-up mimicking that described in ISO 7206-4 (2010).

4. Geometric Data

4.1 Finite element models are based on a geometric representation of the device being studied. The source of the geometric details can be obtained from drawings, solid models, preliminary sketches, or any other source consistent with defining the model geometry. In building the finite element model, certain geometric details may be omitted from the orthopaedic implant geometry shown in the ~~CAD~~ computer-aided design (CAD) model if it is determined that they are not relevant to the intended analysis. Engineering judgment shall be exercised to establish the extent of model simplification and shall be justified.

4.2 It is most appropriate to consider the ~~“worst case”~~ “worst-case” stress condition for the orthopaedic implant being simulated. The ~~“worst case”~~ “worst-case” shall be determined from all relevant engineering considerations, such as stem geometry, dimensions, and head offset. If finite element analysis is being used for determining the worst case, then the worst case head offset may not be known. It may be necessary to run several variants of head ~~offset, in order~~ offset to determine this.

5. Material Properties

5.1 The required material properties for input into an FEA model for the calculation of strains and displacement are modulus of elasticity (E) and Poisson’s ratio (ν). These values can be obtained from material certification data. It should be noted that as ISO 7206-4 (2010) is run under load control, the FEA should also be run under load control. When the FEA is run under load control, the modulus of elasticity will not affect the stress calculations under small displacement theory but will affect displacement and strain. The influence of Poisson’s ratio on the stress calculations is negligible.

5.2 Ensure that material property units are consistent with geometric units in the CAD model. SI units are the preferred units of measure.

<https://standards.iteh.ai/catalog/standards/sist/3264217a-54f0-478a-8875-b85caed0aa5c/astm-f2996-20>

6. Loading

6.1 The loading and orientation of the hip stem shall be guided by ~~the~~ ISO 7206-4 (2010) standard. The areas of particular interest are the stresses in the neck region, driver hole region, potting level, and other design-specific critical regions.

6.2 The load shall be applied such that the magnitude and direction are identical to ~~that~~ those defined in ISO 7206-4 (2010). The point of load application shall produce a statically equivalent bending moment to a load applied through the head center with its ~~worst case~~ head offset.

6.2.1 The load in the model will be applied to the end circular face of the hip stem trunnion or in a justifiably equivalent manner. The trunnion may be extended or truncated to approximate the loading conditions that simulate the ~~worst case~~ worst-case head offset, which may be determined via an iterative process. This approximation should be reported if performed. Alternatively, a rigid couple can be used to tie the load point to the trunnion end circular face. Refer to **Fig. 1**.

6.2.2 It is recognized that the loading conditions in this practice are not identical to that of ISO 7206-4 (2010). However, the ~~difference~~ differences in loading conditions (for example, load applied to surface of head versus face of stem trunnion; potting level differences; use of bone cement which is not modeled in FEA) ~~does~~ should not significantly affect identification of the ~~“worst case”~~ stress condition and construct for subsequent bench testing, “worst-case” stress condition, which is the primary objective of this practice. When subsequent physical fatigue testing per ISO 7206-4 (2010) is performed, comparison of the physical test results (that is, location of origin of distal stem fracture) should be compared to the FEA test results to determine if there were any significant differences. If so, the reason for these differences shall be evaluated, necessary adjustments shall be made to the physical test fixtures or finite element model, and, depending on the result of the analysis, testing of additional components may be necessary.

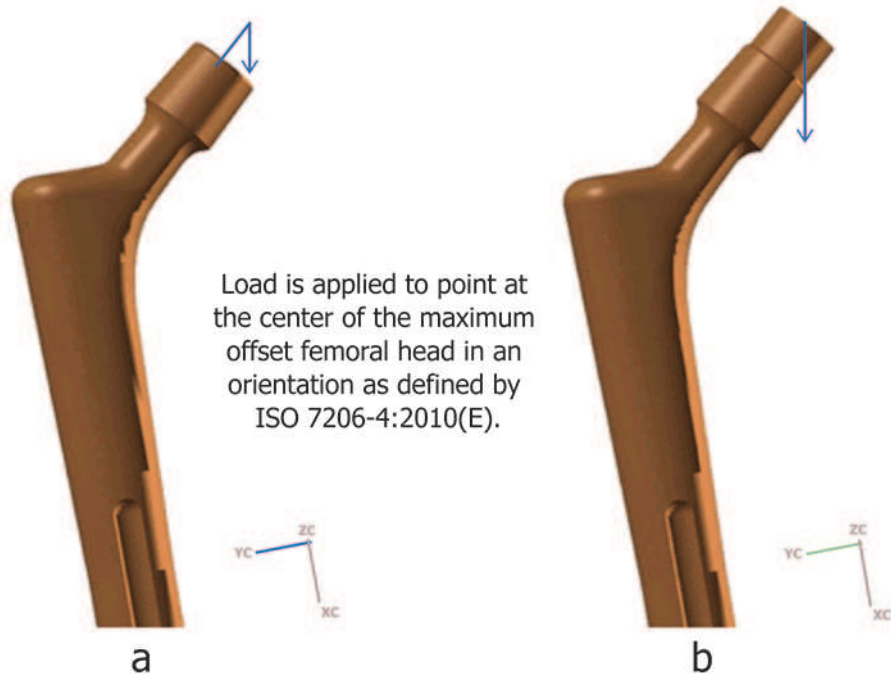

FIG. 1 Load Application

NOTE 1—Generating the statically equivalent maximum bending moment by (a) an offset node tied rigidly to the circular trunnion face, or (b) a cylindrical extension (or truncation of circular trunnion face which equals the maximum femoral head offset (which is an approximation of the offset node method, to be documented if utilized). As an example, the modeling of a +8 mm femoral head offset is shown here. Figures are for illustration purposes only.

NOTE 2—Boundary condition is located at the distal face/cut region of the stem.

ASTM F2996-20

<https://standards.iteh.ai/catalog/standards/sist/3264217a-54f0-478a-8875-b85caed0aa5c/astm-f2996-20>

6.3 Ensure that load units are consistent with material property units.

7. Boundary Conditions

7.1 The hip stem ~~will~~ shall first be ~~cut~~ sectioned at a distance from the center of the head as described in ISO 7206-4 (2010) with the ~~worst case~~ ~~worst-case~~ head/neck offset. This ~~cut~~ sectioned region represents the potting level to which stresses and strains shall be evaluated. A second parallel cut shall then be made 10 mm below the first ~~cut~~ sectioned region. The hip stem shall be constrained in all directions on all faces distal to the second cut. Constraining the stem in this manner ensures that excessive erroneous stresses are not generated at the region of interest due to the influence of rigid fixation. Refer to Fig. 2, Fig. 3, and Fig. 4, which present three stem length variants provided in ISO 7206-4 (2010). The use of other stress evaluation levels or constraint levels, or both, shall be justified.

8. Analysis

8.1 The analysis and modeling system, programs, or software used for the finite element model creation and analysis should be capable of fully developing the geometric features and idealizing the loading and boundary condition environment of the orthopaedic implant. An engineering justification shall be provided to support any assumptions or ~~simplifications, or~~ ~~both~~ simplifications.

8.2 The finite element mesh can be created using automatic meshing, manual meshing, or a combination of the two techniques. The overriding consideration is that the type, the size, and the shape of the elements used must be able to represent the expected behavior without significant numerical limitation or complication. Most FEA packages have a built-in program which checks the shape of the element for the type of analysis selected. If this tool is not available, then additional checks are needed.

Load = 1,200 N

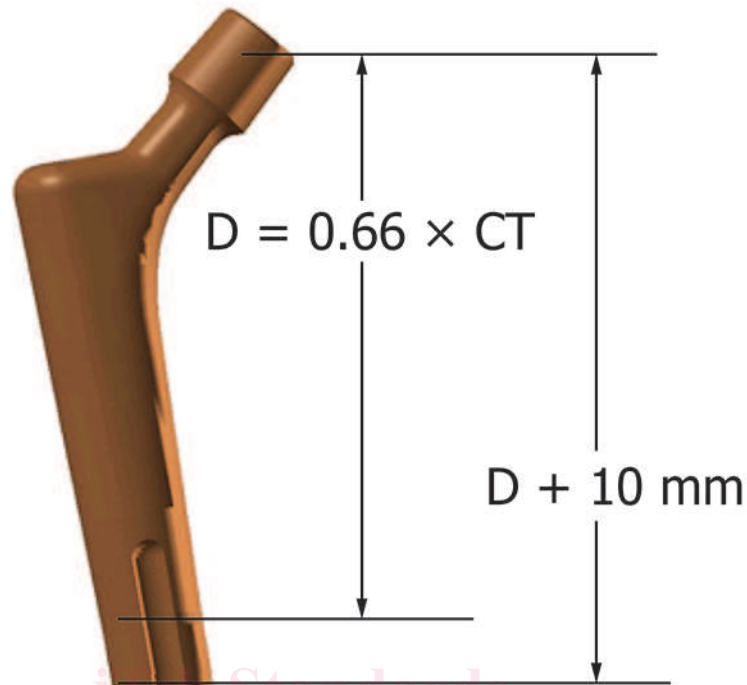

FIG. 2 Boundary Condition Location for Hip Stem Length ≤ 120 mm

NOTE 1—CT: Distance between center of the head and the most distal point of the stem.

NOTE 1—CT is the distance between center of the head and the most distal point of the stem.

NOTE 2—Boundary condition is located at the distal face/cut region of the stem.

ASTM F2996-20

<https://standards.iteh.ai/catalog/standards/sist/3264217a-5440-478a-8875-b85caed0aa5c/astm-f2996-20>

8.3 The number and spacing of nodes (that is, mesh density) should be consistent with the type of element used and the type of result desired. This may be demonstrated with a mesh density study, whereby a series of models with increasing mesh refinement in the critical stress regions is used to demonstrate solution convergence. This allows the error associated with subsequent models to be estimated. The method used to demonstrate mesh convergence, in analysis cases where it is not performed directly onto the model being analyzed, shall be documented in the FEA report. It is recommended that a minimum of three levels of mesh refinement be performed and a model convergence of $\leq 5\%$ is $\leq 5\%$ be demonstrated on all measures and regions the quantity of interest (see 8.6 footnote 3-) and at all regions of interest. A stress convergence of $>5\%$ shall be justified based on the context of use.

8.4 The choice of element type is left to the analyst; however, it is recommended for analysis of a hip stem that tetrahedral or hexahedral elements be used. If tetrahedral elements are considered, use of 4-noded elements should be avoided to prevent stress and strain incompatibilities across elements. Additionally, the linear, 4-noded tetrahedron element is a constant strain element. This means that displacement interpolation is linear and the corresponding stresses and strains are constant within any element. Therefore, a very refined mesh is required around locations where high stress/strain gradients are present when utilizing these elements. When elements are used which are not directly identified in the guide, guide are used, documentation shall be provided in the FEA report which demonstrates their validity.

8.5 The finite element results should be examined to ensure that the geometrical models of the implant, boundary conditions, and applied loads have been appropriately defined in the analysis and properly represent the behavior being analyzed.

8.6 The primary measure of interest is the Maximum (1st) Principal Stress. Refer to Fig. 5. A secondary measure of interest is the von Mises stress at the location of maximum principal stress. If other stress values are used, their validity for use should be documented.

Load = 2,300 N

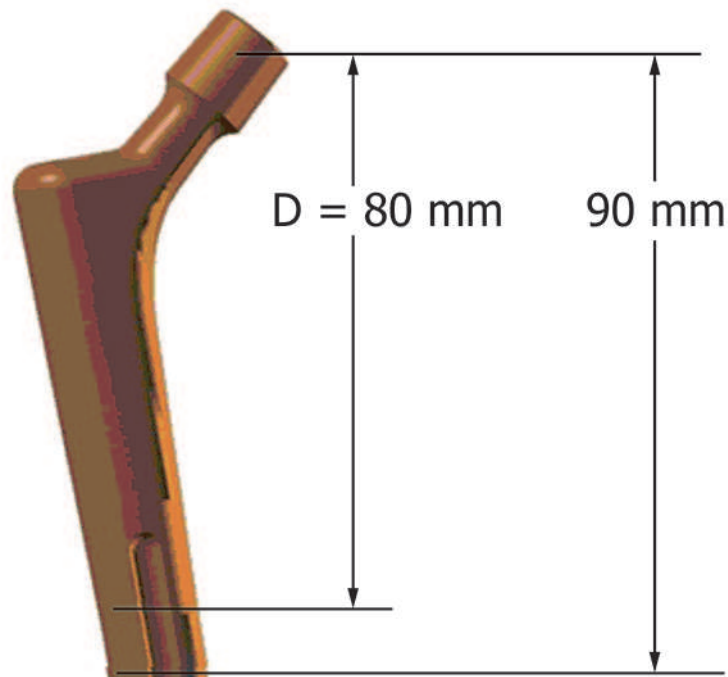

FIG. 3 Boundary Condition Location for Hip Stem Length of 120 mm < CT ≤ 250 mm

NOTE 1—CT: Distance between center of the head and the most distal point of the stem.

NOTE 1—CT is the distance between center of the head and the most distal point of the stem.

NOTE 2—Boundary condition is located at the distal face/cut region of the stem.

9. Report

9.1 The finite element analysis for the evaluation of an orthopaedic implant should be fully documented in an engineering report. The actual format of the report should comply with any acceptable proprietary or non-proprietary engineering report format; however, the report shall include, but is not limited to, the following:

(1) A complete description of the device being analyzed, including detailed dimensions. Report—The report can reference a source CAD geometry file by name and revision number. If the evaluation is not being performed on the final design of the device or if there are other significant assumptions that may limit the use of the results, this must be clearly stated.

(2) A description of boundary constraints, loads, and material properties. the material properties of Young's Modulus and Poisson's ratio as a minimum. The source of the material property data utilized should be referenced.

(3) A summary of the finite element modeling and analysis system used for the analysis. If current versions of widely used, commercially available software are used, this summary can be by name and reference to the version used. For non-commercially available, proprietary tools, or customer user modification of commercially available software, sufficient technical background and results of test problems should be provided to demonstrate the utility, verification, applicability, and limitations of the software tool.

(4) A description of the procedure used to convert the geometric or CAD representation of the device to the finite element model. Any geometry simplifications should be documented.

(5) A description of the finite element model and its relation to the device being evaluated. The number of nodes and elements (or the degrees of freedom in the model), the finite element type selected including (including its capabilities, capabilities), and any special considerations involved in the model should be included. For each region of interest, the maximum (1st) principal stress and von Mises stress at the location of maximum (1st) principal stress shall be reported.

(6) A description of mesh convergence considerations and how they were applied to the analysis.

(7) A description of any numerical considerations or convergence criterion/criteria associated with the analysis.

(8) A summary of analysis results using all appropriate forms of text, graphics, and tabular representations of data to highlight the key behavioral characteristics involved in the evaluation.

(9) Engineering conclusions or recommendations as appropriate.

(10) Deviations from this standard.

Load = 1,200 N

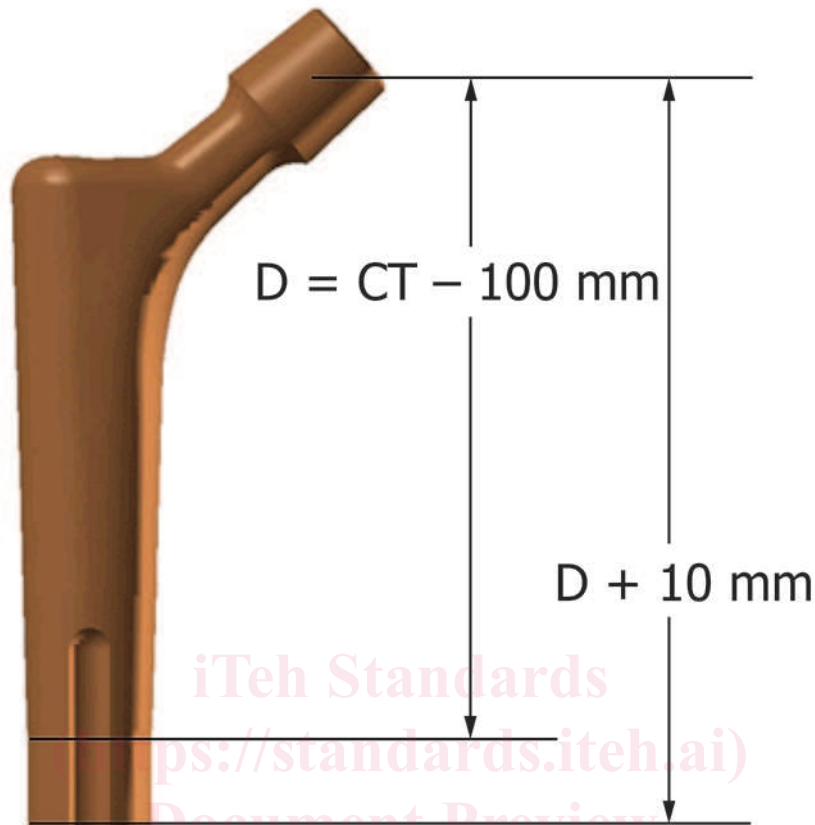

FIG. 4 Boundary Condition Location for Hip Stem Length of $CT > 250$ mm

NOTE 1—CT: Distance between center of the head and the most distal point of the stem.

NOTE 1—CT is the distance between center of the head and the most distal point of the stem.

NOTE 2—Boundary condition is located at the distal face/cut region of the stem.

(11) All relevant references and supporting documentation and drawings.

NOTE 1—Other guidance for reporting of results such as Reporting of Computational Modeling Studies in Medical Device Submissions, Guidance for Industry and Food and Drug Administration Staff, issued on September 21, 2016³ can be referenced.

NOTE 2—Model credibility and validation can also be demonstrated using the methods described in “Assessing Credibility of Computational Modeling through Verification and Validation: Application to Medical Devices.”⁴

10. Precision and Bias

10.1 The precision and bias of this practice ~~has~~ not been established.

11. Keywords

11.1 computational simulations; displacements; FEA; finite element analyses; model calibrations; model validations; model verifications; orthopaedic implants; solution sensitivity; strains; stresses

³ For the referenced FDA Guidance document, visit the FDA website, www.fda.gov.

⁴ For the referenced ASME V&V 40 – 2018 document, visit the ASME website, www.asme.org.

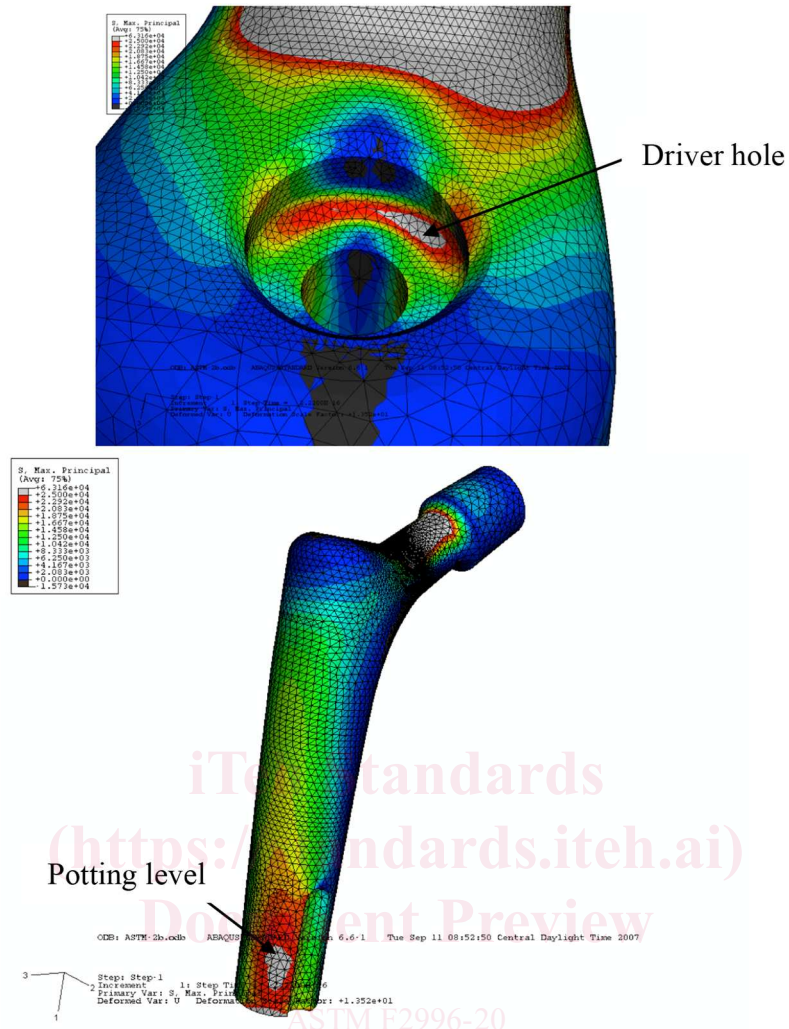

FIG. 5 Typical Maximum Principal Stress Plots for the Driver Hole, Potting Level, and Neck