



# Standard Specification for Solvent Cements for Poly(Vinyl Chloride) (PVC) Plastic Piping Systems<sup>1</sup>

This standard is issued under the fixed designation D2564; the number immediately following the designation indicates the year of original adoption or, in the case of revision, the year of last revision. A number in parentheses indicates the year of last reapproval. A superscript epsilon ( $\epsilon$ ) indicates an editorial change since the last revision or reapproval.

*This standard has been approved for use by agencies of the U.S. Department of Defense.*

## 1. Scope\*

1.1 This specification covers requirements for poly(vinyl chloride) (PVC) solvent cements to be used in joining poly(vinyl chloride) piping systems.

1.2 These solvent cements are used with poly(vinyl chloride) piping systems made from compounds as defined in Specification [D1784](#).

1.3 A two-step procedure for joining PVC pipe and fittings is given in Practice [D2855](#). A one-step procedure for joining PVC pipe and fittings is given in Practice [F3328](#).

1.4 The text of this specification references notes, footnotes, and appendixes which provide explanatory material. These notes and footnotes (excluding those in tables and figures) shall not be considered as requirements of the specification.

1.5 The values stated in inch-pound units are to be regarded as standard. The values given in parentheses are mathematical conversions to SI units that are provided for information only and are not considered standard.

1.6 The following safety hazards caveat pertains only to the test methods portion, Section 6, of this specification: *This standard does not purport to address all of the safety concerns, if any, associated with its use. It is the responsibility of the user of this standard to establish appropriate safety, health, and environmental practices and determine the applicability of regulatory limitations prior to use.*

1.7 *This international standard was developed in accordance with internationally recognized principles on standardization established in the Decision on Principles for the Development of International Standards, Guides and Recommendations issued by the World Trade Organization Technical Barriers to Trade (TBT) Committee.*

<sup>1</sup> This specification is under the jurisdiction of ASTM Committee [F17](#) on Plastic Piping Systems and is the direct responsibility of Subcommittee [F17.20](#) on Joining. Current edition approved Aug. 1, 2020. Published August 2020. Originally approved in 1966. Last previous edition approved in 2018 as D2564 –12(2018). DOI: 10.1520/D2564-20.

## 2. Referenced Documents

### 2.1 ASTM Standards:<sup>2</sup>

[D1084](#) Test Methods for Viscosity of Adhesives

[D1600](#) Terminology for Abbreviated Terms Relating to Plastics

[D1784](#) Classification System and Basis for Specification for Rigid Poly(Vinyl Chloride) (PVC) Compounds and Chlorinated Poly(Vinyl Chloride) (CPVC) Compounds

[D1785](#) Specification for Poly(Vinyl Chloride) (PVC) Plastic Pipe, Schedules 40, 80, and 120

[D2467](#) Specification for Poly(Vinyl Chloride) (PVC) Plastic Pipe Fittings, Schedule 80

[D2855](#) Practice for the Two-Step (Primer and Solvent Cement) Method of Joining Poly (Vinyl Chloride) (PVC) or Chlorinated Poly (Vinyl Chloride) (CPVC) Pipe and Piping Components with Tapered Sockets

[F402](#) Practice for Safe Handling of Solvent Cements, Primers, and Cleaners Used for Joining Thermoplastic Pipe and Fittings

[F412](#) Terminology Relating to Plastic Piping Systems

[F493](#) Specification for Solvent Cements for Chlorinated Poly(Vinyl Chloride) (CPVC) Plastic Pipe and Fittings

[F3328](#) Practice for the One-Step (Solvent Cement Only) Method of Joining Poly (Vinyl Chloride) (PVC) or Chlorinated Poly (Vinyl Chloride) (CPVC) Pipe and Piping Components with Tapered Sockets

### 2.2 National Sanitation Foundation Standards:<sup>3</sup>

[Standard No. 14](#) for Plastic Piping Components and Related Materials

[Standard No. 61](#) for Drinking Water Systems Components—Health Effects

<sup>2</sup> For referenced ASTM standards, visit the ASTM website, [www.astm.org](http://www.astm.org), or contact ASTM Customer Service at [service@astm.org](mailto:service@astm.org). For *Annual Book of ASTM Standards* volume information, refer to the standard's Document Summary page on the ASTM website.

<sup>3</sup> Available from NSF International, P.O. Box 130140, 789 N. Dixboro Rd., Ann Arbor, MI 48113-0140, <http://www.nsf.org>.

\*A Summary of Changes section appears at the end of this standard

### 3. Terminology

3.1 *Definitions*—Definitions are in accordance with Terminology **F412**, and abbreviations are in accordance with Terminology **D1600**, unless otherwise specified.

### 4. Materials and Manufacture

4.1 The solvent cement shall be a solution of the base PVC resin used to make Class 12454-B poly(vinyl chloride) molding or extrusion compound as defined in Specification **D1784**.

4.2 When rework material is used, the manufacturer shall use only his own clean rework material that is compatible with virgin material and produces a cement that meets the requirements of this specification.

4.3 The cement shall be free-flowing and shall not contain lumps, macroscopic undissolved particles, or any foreign matter that will adversely affect the ultimate joint strength or chemical resistance of the cement.

4.4 The cement shall show no gelation. It shall show no stratification or separation that cannot be removed by stirring or shaking.

4.5 When inert fillers are added, the resulting cement shall meet all requirements of this specification.

4.6 The particular solvent system to be used in the formulation of this solvent cement is not specified, since it is recognized that a number of adequate solvent systems for PVC exist. Solvent systems consisting of blends of tetrahydrofuran and cyclohexanone have been found to make cements that are acceptable under the requirements of this specification.

NOTE 1—It is recommended that solvent cements made to this specification *not* be orange since that color is recommended for use with CPVC solvent cement under Specification **F493**.

### 5. Requirements

5.1 *Resin Content*—The PVC resin content shall be 10 % minimum when tested in accordance with **6.1**.

5.2 *Dissolution*—The cement shall be capable of dissolving an additional 3 % by weight of PVC 12454-B compound (either powder or granular) or the equivalent PVC resin at 73.4 ± 3.6 °F (23 ± 2 °C) without evidence of gelation.

5.3 *Viscosity*—Cements are classified as regular-, medium-, or heavy-bodied types, based on their minimum viscosity when tested in accordance with **6.1.1**.

5.3.1 Regular-bodied cements shall have a minimum viscosity of 90 cP (90 mPa·s).

5.3.2 Medium-bodied cements shall have a minimum viscosity of 500 cP (500 mPa·s).

5.3.3 Heavy-bodied cements shall have a minimum viscosity of 1600 cP (1600 mPa·s).

NOTE 2—Refer to **Appendix X1** for guidelines in selecting PVC solvent cements for joining different pipe sizes.

5.4 *Lap Shear Strength*—The minimum average lap shear strength, when tested in accordance with **6.3.2**, shall be 250 psi (1.7 MPa) after a 2-h curing time, 500 psi (3.4 MPa) after a 16-h curing time, and 900 psi (6.2 MPa) after a 72-h curing time.

NOTE 3—These values should not be used for designing piping joints.

5.5 *Hydrostatic Burst Strength*—The minimum average hydrostatic burst strength, when tested in accordance with **6.3.3**, shall be 400 psi (2.8 MPa) after a 2-h curing time.

### 6. Test Methods

6.1 *Solids Content*:

6.1.1 *Apparatus*:

6.1.1.1 *Ointment Tins* (Style No. 12, 1-oz (30-mL), all metal).

6.1.1.2 *Vacuum Oven*

6.1.1.3 *Analytical Balance*

6.1.1.4 *Centrifuge*.

6.1.2 *Procedure*:

6.1.2.1 Stir the sample thoroughly with a spatula before weighing (**Note 4**). Weigh 3.0 ± 0.5 g of the sample to the nearest 1 mg into a tared ointment tin. Place tin into the vacuum oven (**Note 5**), and heat at 248 °F (120 °C) for 45 min +15, –0 min. Discard specimens left in for more than 1 h. The vacuum must be continually in operation to draw off flammable solvents and shall be maintained at 15 mm Hg minimum. Remove the tin from the oven and place in a desiccator until cooled to room temperature. Weigh the tin and dried sample to the nearest 1 mg.

NOTE 4—This material is usually nonhomogeneous and shall be thoroughly stirred before weighing. The weighing shall also be accomplished quickly to avoid loss of solvent by volatilization.

NOTE 5—The use of a vacuum oven is mandatory for drying the specimen, because this oven has neither an exposed heating surface nor an open flame, thus avoiding the danger of flashing. The oven also provides an open vacuum to exhaust solvent fumes.

6.1.2.2 After weighing, dissolve most of the dried sample by adding 15 mL of tetrahydrofuran (THF) to the sample in the ointment tin and stirring with a glass rod for 15 min. Collect the liquid decanted from this step, plus the liquid from the next two steps. Dissolve the remainder with a second addition of 15 mL of THF, followed by a third addition of 5 mL of THF to rinse the ointment tin. Centrifuge the entire volume at 20 000 r/min for 15 min. Discard the supernatant liquid. Add 15 mL of THF to the tube, mix thoroughly, and transfer the tube contents to the ointment tin. Use 2 mL more of THF to wash down the tube, and pour into the ointment tin. Evaporate off the THF in the vacuum oven at 248 °F (120 °C) for 45 min. Cool in desiccator, weigh the tin to the nearest 1 mg, and calculate the percent of inert filler present in the cement.

6.1.3 *Calculation*—Calculate the percentage of PVC resin as follows:

$$\text{Resin, \%} = [(B - A - D)/(C - A)] \times 100 \quad (1)$$

where:

A = weight of ointment tin,

B = weight of tin and specimen after drying,

C = weight of tin and specimen before drying, and

D = weight of inert filler, if present.

NOTE 6—Other methods for determination of resin and inert filler content may be used provided the results of the alternative method are as accurate and consistent as the above method.

6.2 *Viscosity*—Measure the viscosity in accordance with Method B of Test Methods **D1084**, except that conditioning to

temperature equilibrium only is required. For qualification purposes, use a Model RVF viscometer, a speed of 10 r/min, and the spindle that, by trial, gives the closest reading to center range of scale for the cement being tested. Other speeds are also used for quality control purposes.

6.3 Bond Strength:

6.3.1 Number of Specimens—A minimum of seven specimens shall be tested for the lap shear strength test (see 5.4). A minimum of five specimens shall be tested for the hydrostatic burst strength test (see 5.4).

6.3.2 Lap Shear Strength:

6.3.2.1 Cut 1 by 1-in. (25 by 25-mm) and 1 by 2-in. (25 by 50-mm) sections from 1/4-in. (6-mm) thick sheet made from Class 12454-B PVC. One section of each size is required for each test specimen (Fig. 1).

6.3.2.2 Clean the surfaces to be adhered with a cloth dampened with methyl ethyl ketone (MEK).

6.3.2.3 Using a 1-in. (25-mm) bristle brush, apply a thin layer of cement to the complete surface of a 1 by 1-in. (25 by 25-mm) sheet section and to the center of a 1 by 2-in. (25 by 50-mm) sheet section.

6.3.2.4 Assemble these sections immediately and rotate the 1 by 1-in. (25 by 25-mm) section 180° on the 1 by 2-in. (25 by 50-mm) section, within 5 s, using light hand pressure (approximately 0.5 lb (2 N)).

6.3.2.5 Place the assembled test specimen on a clean, level surface using the 1 by 2-in. (25 by 50-mm) section as a base. After 30 s, place a 2-kg weight on the test specimen for a period of 3 min, then remove.

6.3.2.6 Store the assembled test specimens at 73.4 ± 3.6 °F (23 ± 2 °C) for the specified time and test immediately in a holding fixture similar to that shown in Fig. 2. The shear speed shall be 0.05 in. (1.25 mm)/min. Express the results in pounds per square inch (or megapascals).

6.3.2.7 Disregard the lowest and highest value for the calculation of the average lap shear strength.

6.3.3 Hydrostatic Burst Strength:

6.3.3.1 Use 2-in. (50-mm) PVC Schedule 80 pipe meeting the requirements of Specification D1785 and PVC Schedule 80 couplings meeting the requirements of Specification D2467, except that the socket depth shall be 1.5 in. (38 mm). The dimensions of the pipe and fitting socket shall be such that the pipe will enter the socket from one third to two thirds of the full socket depth dry when assembled by hand.

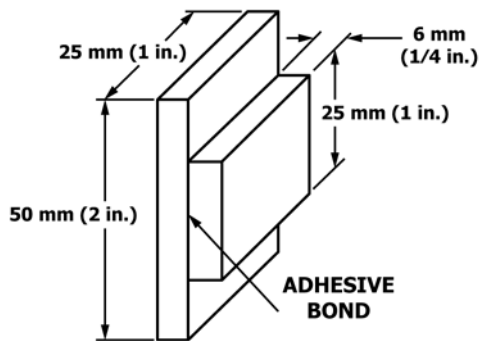

FIG. 1 Compression Shear Specimen

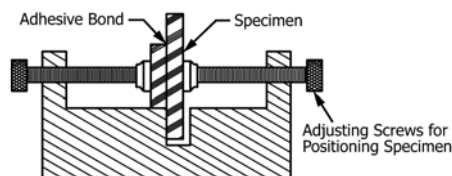

FIG. 2 Typical Specimen-Holding Device

6.3.3.2 Cut the pipe into 6-in. (150-mm) lengths and join to the couplings as in Practice D2855 except only wipe with a clean dry rag. The pipe must be fully bottomed in the fitting socket.

NOTE 7—Do not apply cleaner or primer since the purpose of the test is to evaluate the cement, alone.

6.3.3.3 Close the ends of the test specimens with suitable end closures for pressure testing.

6.3.3.4 Store the specimens at 73.4 ± 3.6 °F (23 ± 2 °C) for 2 h ± 5 min; then test immediately.

6.3.3.5 Increase the internal hydrostatic pressure at the rate of 200 psi (1.4 MPa)/min ± 10 % until failure occurs.

7. Retest and Rejection

7.1 If the results of any test(s) do not meet the requirements of this specification, the test(s) shall be conducted again only by agreement between the purchaser and the seller. Under such agreement, minimum requirements shall not be lowered, nor tests omitted, substituted, changed, or modified, nor shall specification limits be changed. If upon retest, failure occurs, the quantity of product represented by the test(s) does not meet the requirements of this specification.

8. Report

- 8.1 Report the following information:
  - 8.1.1 Name of cement manufacturer,
  - 8.1.2 Lot number,
  - 8.1.3 Total PVC resin, % W,
  - 8.1.4 Dissolution, pass or fail,
  - 8.1.5 Viscosity,
  - 8.1.6 Average lap shear strength at each cure time and complete identification of PVC sheet stock used for tests,
  - 8.1.7 Average hydrostatic burst strength, and
  - 8.1.8 Total inert filler, % W.

9. Certification

9.1 When specified in the purchase order, the manufacturer shall certify to the buyer or to his nominee that the products in the specified lots meet all the requirements of this specification and when requested, shall include a copy of the manufacturer’s routine quality control tests results to document that the specification requirements have been met. Each certification so furnished shall be signed by an authorized agent of the manufacturer.

10. Container Labeling and Marking

10.1 Container labeling of cement shall include the following:

- 10.1.1 Manufacturer’s or supplier’s name and address and tradename or trademark,