



Designation: ~~D2665—14~~ **D2665 – 20**

An American National Standard

# Standard Specification for Poly(Vinyl Chloride) (PVC) Plastic Drain, Waste, and Vent Pipe and Fittings<sup>1</sup>

This standard is issued under the fixed designation D2665; the number immediately following the designation indicates the year of original adoption or, in the case of revision, the year of last revision. A number in parentheses indicates the year of last reapproval. A superscript epsilon ( $\epsilon$ ) indicates an editorial change since the last revision or reapproval.

*This standard has been approved for use by agencies of the U.S. Department of Defense.*

## 1. Scope\*

1.1 This specification covers requirements and test methods for materials, dimensions and tolerances, pipe stiffness, crush resistance, impact resistance, and solvent cement for poly(vinyl chloride) plastic drain, waste, and vent pipe and fittings. A form of marking is also included. Plastic which does not meet the material requirements specified in Section 5 is excluded. Installation procedures are given in the Appendix.

1.2 The values stated in inch-pound units are to be regarded as standard. The values given in parentheses are mathematical conversions to SI units that are provided for information only and are not considered standard.

1.3 The text of this specification references notes, footnotes, and appendixes which provide explanatory material. These notes and footnotes (excluding those in tables and figures) shall not be considered as requirements of the specification.

1.4 The following safety hazards caveat pertains only to the test methods portion, Section 7, of this specification: *This standard does not purport to address all of the safety concerns, if any, associated with its use. It is the responsibility of the user of this standard to establish appropriate safety, health, and environmental practices and determine the applicability of regulatory limitations prior to use.*

1.5 *This international standard was developed in accordance with internationally recognized principles on standardization established in the Decision on Principles for the Development of International Standards, Guides and Recommendations issued by the World Trade Organization Technical Barriers to Trade (TBT) Committee.*

## 2. Referenced Documents

### 2.1 ASTM Standards:<sup>2</sup>

D618 Practice for Conditioning Plastics for Testing

D1600 Terminology for Abbreviated Terms Relating to Plastics

D1784 Classification System and Basis for Specification for Rigid Poly(Vinyl Chloride) (PVC) Compounds and Chlorinated Poly(Vinyl Chloride) (CPVC) Compounds

D2122 Test Method for Determining Dimensions of Thermoplastic Pipe and Fittings

D2412 Test Method for Determination of External Loading Characteristics of Plastic Pipe by Parallel-Plate Loading

D2444 Practice for Determination of the Impact Resistance of Thermoplastic Pipe and Fittings by Means of a Tup (Falling Weight)

<sup>1</sup> This specification is under the jurisdiction of ASTM Committee F17 on Plastic Piping Systems and is the direct responsibility of Subcommittee F17.63 on DWV. Current edition approved May 1, 2014; Aug. 1, 2020. Published June 2014; August 2020. Originally approved in 1968. Last previous edition approved in 2012 as D2665—12; D2665 – 14. DOI: 10.1520/D2665-14; 10.1520/D2665-20.

<sup>2</sup> For referenced ASTM standards, visit the ASTM website, www.astm.org, or contact ASTM Customer Service at service@astm.org. For Annual Book of ASTM Standards volume information, refer to the standard's Document Summary page on the ASTM website.

\*A Summary of Changes section appears at the end of this standard

[D2564](#) Specification for Solvent Cements for Poly(Vinyl Chloride) (PVC) Plastic Piping Systems  
[D3311](#) Specification for Drain, Waste, and Vent (DWV) Plastic Fittings Patterns  
[F402](#) Practice for Safe Handling of Solvent Cements, Primers, and Cleaners Used for Joining Thermoplastic Pipe and Fittings  
[F412](#) Terminology Relating to Plastic Piping Systems  
[F1498](#) Specification for Taper Pipe Threads 60° for Thermoplastic Pipe and Fittings  
[F1866](#) Specification for Poly (Vinyl Chloride) (PVC) Plastic Schedule 40 Drainage and DWV Fabricated Fittings  
[F2135](#) Specification for Molded Drain, Waste, and Vent (DWV) Short-Pattern Plastic Fittings

### 3. Terminology

3.1 Definitions are in accordance with Terminology [F412](#), and abbreviations are in accordance with Terminology [D1600](#), unless otherwise specified.

### 4. Significance and Use

4.1 The requirements of this specification are intended to provide pipe and fittings suitable for the drainage and venting of sewage and certain other liquid wastes.

NOTE 1—Industrial waste disposal lines should be installed only with the specific approval of the cognizant building code authority since chemicals not commonly found in drains and sewers and temperatures in excess of ~~180°F (82.2°C)~~ 180 °F (82.2 °C) may be encountered.

NOTE 2—This specification does not include requirements for pipe and fittings intended to be used to vent combustion gases.

### 5. Materials

5.1 *Basic Materials*—The pipe shall be made of virgin PVC compounds meeting or exceeding the requirements of Class 12454 as defined in Specification [D1784](#). The fittings shall be made of virgin PVC compounds meeting or exceeding the requirements of Class 12344 as defined in Specification [D1784](#), but with a tensile strength of not less than 6500 psi and a modulus of elasticity for not less than ~~380,000~~ 380 000 psi. These plastics contain stabilizers, lubricants, and pigments.

5.2 *Rework Material*—The manufacturer shall use only his own clean pipe or fitting rework material, and the pipe or fittings produced shall meet all the requirements of this specification.

5.3 *Solvent Cement*—The solvent cement used to join pipe and fittings made to this specification shall meet the requirements of Specification [D2564](#).

### 6. Requirements

6.1 *General*—The pipe and fittings shall be homogeneous throughout and free of visible cracks, holes, foreign inclusions, or other injurious defects. The pipe shall be as uniform as commercially practicable in color, opacity, density, and other physical properties.

6.1.1 The requirements in this section are intended only for use as quality control tests, not as simulated service tests.

6.2 *Dimensions and Tolerances:*

6.2.1 *Method*—All dimensions shall be determined in accordance with Test Method [D2122](#).

6.2.2 *Dimensions:*

6.2.2.1 The outside diameter and wall thicknesses of pipe shall meet the requirements of [Table 2](#). The pipe shall be in either 10 or ~~20-ft~~ 20 ft (3.05 or ~~6.1-m~~) 6.1 m lengths, unless otherwise specified, with an allowable tolerance of +½, -0 in. (+13, -0 mm).

6.2.2.2 The patterns, dimensions, and laying lengths of fittings, including adaptors, shall meet the requirements of Specification [D3311](#) and [Table 1](#).

6.2.2.3 Reducer bushings of sizes 2 by 1¼ and 4 by 3 shall be permitted to have the socket wall thickness and spigot wall thickness below the minimum requirements defined in [Table 1](#), but not less than 0.098 in. (2.5 mm), provided the inner socket and outer spigot are reinforced by a minimum of four ribs. The thickness of the supporting ribs shall not be less than 0.098 in. (2.5 mm).

TABLE 1 Dimensions and Tolerances for Fitting Sockets for PVC Schedule 40 Drain, Waste and Vent Pipe Fittings

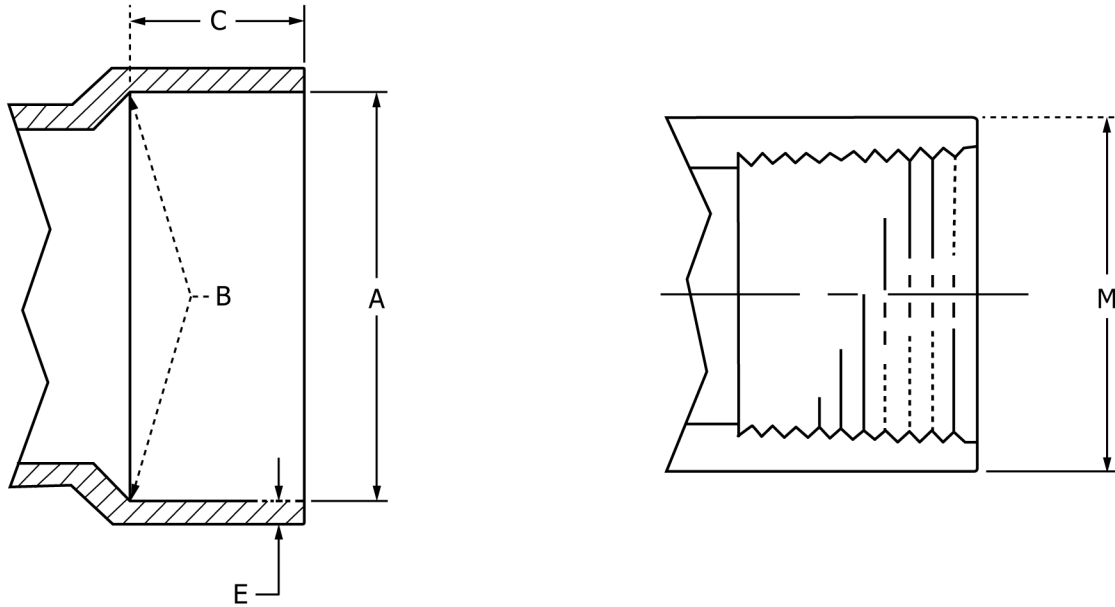

Nominal Pipe Size	A			B			C	E	M			
	Socket Entrance Diameter			Socket Bottom Diameter					Socket Depth, min	Wall thickness min. <sup>A</sup>	Internal Threads	
	Average	Tolerance on Avg.	Out-of-Roundness	Average	Tolerance on Avg.	Out-of-Roundness					Outside Diameter of Hub, M. min.	Thread length min.
	in. (mm)											
1¼	1.675 (42.54)	+0.010/-0.005 (+0.25/-0.13)	0.024 (0.61)	1.655 (42.04)	±0.005 (±0.13)	0.024 (0.61)	0.687 (17.44)	0.156 (3.96)	1.871 (47.52)	0.687 (17.44)		
1½	1.915 (48.64)	+0.010/-0.005 (+0.25/-0.13)	0.024 (0.61)	1.894 (48.11)	±0.006 (±0.15)	0.024 (0.61)	0.687 (17.44)	0.156 (3.96)	2.127 (54.03)	0.687 (17.44)		
2	2.390 (60.71)	+0.010/-0.005 (+0.25/-0.13)	0.024 (0.61)	2.369 (60.17)	±0.006 (±0.15)	0.024 (0.61)	0.750 (19.05)	0.156 (3.96)	2.634 (66.90)	0.750 (19.05)		
3	3.520 (89.41)	+0.010/-0.005 (+0.25/-0.13)	0.030 (0.76)	3.492 (88.70)	±0.008 (±0.20)	0.030 (0.76)	1.500 (38.10)	0.219 (5.56)	3.841 (97.56)	1.187 (30.15)		
4	4.520 (114.8)	+0.010/-0.005 (+0.25/-0.13)	0.030 (0.76)	4.491 (114.1)	±0.009 (±0.23)	0.030 (0.76)	1.750 (44.45)	0.250 (6.35)	4.907 (124.6)	1.28 (32.54)		
6	6.647 (168.8)	+0.015/-0.010 (+0.38/-0.25)	0.060 (1.52)	6.614 (168.0)	±0.011 (±0.28)	0.060 (1.52)	3.000 (76.20)	0.281 (7.14)	7.203 (183.0)	1.500 (38.10)		
8	8.655 (219.8)	+0.030/-0.000 (+0.76/-0.00)	0.090 (2.29)	8.610 (218.7)	±0.015 (±0.38)	0.090 (2.29)	4.000 (101.6)	0.328 (8.33)	<i>B</i>	<i>B</i>		
10	10.780 (273.8)	+0.025/-0.020 (+0.64/-0.51)	0.120 (3.05)	10.737 (272.7)	±0.015 (±0.38)	0.120 (3.04)	5.000 (127.0)	0.365 (9.28)	<i>B</i>	<i>B</i>		
12	12.780 (324.6)	+0.030/-0.025 (+0.76/-0.64)	0.150 (3.81)	12.736 (323.5)	±0.015 (±0.38)	0.150 (3.81)	6.000 (152.4)	0.406 (10.3)	<i>B</i>	<i>B</i>		

<sup>A</sup> The value for wall thickness shown in Table 1 is an averaged minimum. An averaged minimum is derived by adding two wall thicknesses that are directly opposite each other and dividing the result by 2. The reason for an averaged minimum wall thickness is due to core shift which is a normal occurrence found in fittings that are injection molded. When core shift occurs, the result is a pair of high and low wall thickness readings. The average of the high and the low wall thickness readings must equal or exceed the averaged minimum value shown in Table 1. The low wall thickness reading shall not be more than +9%10 % below the averaged minimum value shown in Table 1. This applies to any point on the fitting (hub, body, or spigot). In cases where there is no opposite side (as in the case of a portion of the branch of a wye fitting) then the single wall thickness reading shall not be more than +9%10 % below the averaged minimum value shown in Table 1.

<sup>B</sup> Not applicable for these nominal sizes.

6.2.2.4 The patterns, dimensions, and laying lengths of Short-Pattern fittings shall meet the requirements of Specification F2135.

6.2.2.5 For all fittings having taper pipe threads, threads shall conform to Specification F1498 and be gaged in accordance with 7.5. Fittings of nominal sizes not given in Specification F1498 shall not have threads.

**TABLE 2 Dimensions and Tolerances for Outside Diameters and Thicknesses of PVC Plastic Drain, Waste, and Vent Pipe**

Nominal Pipe Size	Outside Diameter			Wall Thickness	
	Average	Tolerance on Average	Out-of-Roundness (maximum minus minimum)	Minimum	Tolerance
in. (mm)					
1¼	1.660 (42.16)	±0.005 (0.13)	0.024 (0.61)	0.140 (3.56)	+0.020 (0.51) -0.000
1½	1.900 (48.26)	±0.006 (0.15)	0.024 (0.61)	0.145 (3.68)	+0.020 (0.51) -0.000
2	2.375 (60.33)	±0.006 (0.15)	0.024 (0.61)	0.154 (3.91)	+0.020 (0.51) -0.000
3	3.500 (88.90)	±0.008 (0.20)	0.030 (0.76)	0.216 (5.49)	+0.026 (0.66) -0.000
4	4.500 (114.30)	±0.009 (0.23)	0.100(2.54)	0.237 (6.02)	+0.028 (0.71) -0.000
6	6.625 (168.28)	±0.011 (0.28)	0.100 (2.54)	0.280 (7.11)	+0.034 (0.86) -0.000
8	8.625 (219.08)	±0.015 (0.38)	0.150 (3.81)	0.322 (8.18)	+0.039 (0.99) -0.000
10	10.750 (273.05)	±0.015 (0.38)	0.150 (3.81)	0.365 (9.27)	+0.044 (1.12) -0.000
12	12.750 (323.85)	±0.015 (0.38)	0.150 (3.81)	0.406 (10.31)	+0.049 (1.24) -0.000
14	14.000 (355.60)	±0.015 (±0.38)	0.200 (5.08)	0.437 (11.1)	+0.053 (1.35) -0.000
16	16.000 (406.40)	±0.019 (±0.48)	0.320 (8.13)	0.500 (12.7)	+0.060 (1.52) -0.000
18	18.000 (457.20)	±0.019 (±0.48)	0.360 (9.20)	0.562 (14.27)	+0.067 (1.71) -0.000
20	20.000 (508.00)	±0.023 (±0.58)	0.400 (10.20)	0.593 (15.06)	+0.071 (1.81) -0.000
24	24.000 (609.60)	±0.031 (±0.79)	0.480 (12.20)	0.687 (17.45)	+0.082 (2.09) -0.000

  
<https://standards.iteh.ai>  
 Document Preview

6.2.2.6 Fabricated DWV fittings shall comply with Specification **F1866**.

[ASTM D2665-20](https://standards.iteh.ai/standards/astm/d2665-20)

6.3 *Pipe Stiffness, Deflection Load and Flattening:* [ast/55a66c58-132d-4156-bb93-2446e483e722/astm-d2665-20](https://standards.iteh.ai/standards/astm/d2665-20)

6.3.1 *Pipe*—The minimum pipe stiffness at 5 % deflection shall be in accordance with **Table 3**. The pipe shall deflect by 60 % of the nominal outside diameter (flattening) without cracking, rupture, or other visible evidence of failure when tested in accordance with **7.4**.

6.3.1.1 *Pipe Stiffness (PS)*—Three specimens shall be tested. If all three meet the PS requirement, the sample meets the PS requirement. If one or two fail, additional testing shall be conducted in accordance with **6.3.1.2**. If all three fail, the sample does not meet the PS requirement.

6.3.1.2 *Pipe Stiffness and Lower Confidence Limit*—In the event that one or two of the specimens tested in **6.3.1** fail to meet the minimum PS requirement, the average pipe stiffness of eleven specimens shall meet or exceed the minimum requirement given in **Table 3**. The 99 % lower confidence limit (LCL) shall be within 15 % of the average value. The LCL shall be calculated using the Student’s “*t*” distribution, with *N*-1 degrees of freedom, where *N* is the number of specimens. The critical *t* value shall be used to at least three significant digits. Alternatively, if the LCL exceeds the minimum PS requirement in **Table 3**, but is not within 15 % of the average, the sample meets the requirements of the pipe stiffness testing. The eleven specimens include the three tested under **6.3.1**, and an additional eight with rotation by 35°, as specified in Test Method **D2412**, continuing throughout the remaining specimens.

6.3.1.3 The LCL based on testing eleven specimens is calculated as follows:

$$LCL = (\text{avg PS}) - \left\{ 2.76(\text{std. dev.})/\sqrt{(N)} \right\} \quad (1)$$

where:

$$(\text{avg PS}) = \left[ \sum (PS_i) \right] / \quad (2)$$

**TABLE 3 Pipe Stiffness Requirements for PVC DWV Pipe<sup>A</sup>**

Nominal Pipe Size, in.	Pipe Stiffness, min, psi (kPa)
1¼	1400 (9650)
1½	1010 (6960)
2	600 (4140)
3	510 (3520)
4	310 (2140)
6	150 (1030)
8	100 (690)
10	78 (530)
12	63 (430)
14	60 (415)
16	60 (415)
18	60 (415)
20	51 (350)
24	45 (315)

<sup>A</sup> Measured at 5 % deflection.

$$(\text{std. dev.}) = \left[ \frac{\sum PS^2 - (\sum PS)^2 / N}{N - 1} \right]^{1/2}$$

N = 11

6.3.1.4 The 15 % requirement is calculated as follows:

$$(\text{Avg} - LCL) / (\text{Avg}) \times 100 \leq 15 \% \quad (3)$$

NOTE 3—The 5 % deflection criterion, which was arbitrarily selected for testing convenience, should not be considered as a limitation with respect to in-use deflection. The engineer is responsible for establishing the acceptable deflection.

6.3.2 *Fittings*—Individual fittings unassembled shall withstand a minimum load of 750 lbf/ft (11 kN/m) of centerline length without cracking or other visible evidence of failure when tested in accordance with 7.4.

6.4 *Impact Resistance*—The minimum impact resistance of pipe and fittings, when tested at the time of manufacture, shall comply with Table 4. Test in accordance with Test Method D2444 using Tup C and Holder A for pipe and Tup A and Holder B for fittings. Use a 12-lb (5-kg) tup for testing pipe sizes 4 in. and smaller and a 20-lb (10-kg) tup for pipe larger than 4 in. Test fittings with a 12-lb (5-kg) Tup. Test couplings cemented to short pieces of pipe and allowed to dry for 24 h. For fittings larger than 4-in, a symmetric section cut from the hub or body with a minimum centerline length of 2 in. shall be permitted to be used rather than the entire fitting.

**TABLE 4 Impact Resistance of PVC Plastic Drain, Waste and Vent Pipe and Fittings**

Description	Impact Resistance, min., ft-lbf (J) 73°F (23°C)
All pipe sizes	60 (81)
Fitting sizes and types (larger than 2 in. nominal OD)	15 (20)
Fitting sizes and types (2 in. and smaller nominal OD)	7.5 (10)

6.4.1 Test 10 specimens. When 9 or 10 specimens pass, accept the lot. When 2 or more specimens fail, test 10 additional specimens. When 17 of 20 specimens tested pass, accept the lot. When 4 or more of 20 specimens tested fail, test 20 additional specimens. When 32 of 40 specimens pass, accept the lot. When 9 or more of 40 specimens fail, the lot does not meet the requirements of this specification.

6.4.2 Failure in the test specimens shall be shattering or any crack or break extending entirely through the pipe wall and visible to the unaided eye.

6.4.3 Bushings increasers and closet flanges are exempt from this requirement.

## 7. Test Methods

7.1 *Sampling*—A sample of the pipe and fittings sufficient to determine conformance with this specification shall be taken at random from each lot or shipment. About 40 ft (12 m) of pipe are required to make the tests prescribed. The number of fittings required varies depending on the size and type of fitting.

7.1.1 *Test Specimens*—Not less than 50 % of the test specimens required for any pressure test shall have at least a part of the marking in their central sections. The central section is that portion of pipe which is at least one pipe diameter away from an end closure.

[ASTM D2665-20](https://standards.iteh.ai/catalog/standards/sist/55a66c58-132d-4156-bb93-2446e483e722/astm-d2665-20)

<https://standards.iteh.ai/catalog/standards/sist/55a66c58-132d-4156-bb93-2446e483e722/astm-d2665-20>

### 7.2 Conditioning:

7.2.1 For referee purposes, condition the specimens prior to test at  $73.4 \pm 3.6^{\circ}\text{F}$  ( $23 \pm 2^{\circ}\text{C}$ ) and  $50 \pm 5\%$  relative humidity in accordance with Practice **D618**, Procedure A.

7.2.2 For routine quality control testing, condition the specimens at the temperature and humidity of the manufacturers testing facility for not less than 1 h or until the specimens are at the room temperature.

### 7.3 Test Conditions:

7.3.1 For referee purposes, conduct tests in the standard laboratory atmosphere of  $73.4 \pm 3.6^{\circ}\text{F}$  ( $23 \pm 2^{\circ}\text{C}$ ) and  $50 \pm 5\%$  relative humidity.

7.3.2 For routine control testing, conduct tests at the room temperature and humidity of the manufacturers testing area.

7.4 *Pipe Stiffness, Deflection Load, and Flattening*—Measure the pipe stiffness, the flattening of pipe and the deflection load of fittings in accordance with Test Method **D2412**. In the test for pipe, note the load when the initial diameter is reduced 5 % (pipe stiffness). Continue test until the diameter is deflected by 60 % of its original value (flattening). The rate of head approach shall be a minimum of 0.5 in./min (12.5 mm/min). In case of disagreement, the referee test speed shall be  $0.50 \pm 0.02$  in./min ( $12.5 \pm 0.05$  mm/min).

7.4.1 *Pipe*—Three specimens, each  $6 \pm \frac{1}{4}$  in. ( $150 \pm 3$  mm) long, shall be tested. The ends shall be cut square and free of burrs and jagged edges. Each specimen shall meet the requirements of **6.3.1**.

7.4.2 *Fittings*—Test three complete fittings. Each specimen shall meet the requirement of 6.3.2. Shim fittings to give full centerline contact with platens. Fittings having nonuniform diameters, such as reducers, shall be considered acceptable when the wall thickness at all points is equal to or greater than the wall thickness of pipe of the same material and diameter that meets the crush resistance requirements.

7.4.3 *Procedure*—Terminate the test when the diameter of pipe test specimens is reduced to 40 % of its original value or the pipe cracks or shows other evidence of visible failure. Terminate the test on fittings when the load reaches 750 lbf/ft (11 kN/m) of centerline length. Observe the load and deflection at the first evidence of cracking, if any. Record location and type of failure.

7.4.4 *Calculations*—For pipe, divide the load at failure (flattening) if such occurred, by the length of the pipe test specimen to obtain the flattening resistance. Express results in N/m or lbf/ft. Calculate the values for each specimen of pipe and fittings for conformance to the requirements of 6.3.1 and 6.3.2. For calculation of pipe stiffness, refer to the Calculation Section and the Appendix of Test Method D2412. Calculate the values for each specimen separately. Examine the results for each specimen of pipe for conformance to the requirements of Table 3.

7.5 *Threads*—All taper pipe threads shall be gaged in accordance with Specification F1498.

## 8. Retest and Rejection

8.1 If the results of any test(s) do not meet the requirements of this specification, the test(s) shall be conducted again only by agreement between the purchaser and the seller. Under such agreement, minimum requirements shall not be lowered, changed, or modified, nor shall specification limits be changed. If, upon retest, failure occurs, the quantity of product represented by the test(s) does not meet the requirements of this specification.

## 9. Product Marking

9.1 *Pipe*—The pipe shall be marked in letters not less than  $\frac{3}{16}$  in. (5 mm) high, in a contrasting color, and shall at least consist of the manufacturer's name or trademark, the designation ASTM D2665, the nominal pipe size, the symbol PVC, and the symbol DWV, spaced at intervals of not more than 5 ft (1.5 m).

NOTE 4—It is common practice to dual mark Schedule 40 DWV and potable water piping in which compliance with each applicable standard is met. This is NOT an acceptable practice when external recycled material is used in the manufacture of the pipe.

9.2 *Fittings*—Fittings shall be marked on the body or hub with the manufacturer's name or trademark, and the symbol PVC.

## 10. Quality Assurance

10.1 When the product is marked with this designation, D2665, the manufacturer affirms that the product was manufactured, inspected, sampled, and tested in accordance with this specification and has been found to meet the requirements of this specification.

## 11. Keywords

11.1 DWV; fittings; pipe; plastic; PVC; Schedule 40; thermoplastic