



Designation: D1403 – 20b



Designation: 310/84 (92)

Standard Test Methods for Cone Penetration of Lubricating Grease Using One-Quarter and One-Half Scale Cone Equipment¹

This standard is issued under the fixed designation D1403; the number immediately following the designation indicates the year of original adoption or, in the case of revision, the year of last revision. A number in parentheses indicates the year of last reappraisal. A superscript epsilon (ϵ) indicates an editorial change since the last revision or reappraisal.

This standard has been approved for use by agencies of the U.S. Department of Defense.

1. Scope*

1.1 These test methods cover two procedures for measuring the consistency of small samples of lubricating greases by penetration of a ¼-scale cone or a ½-scale cone. These test methods include procedures for the measurement of unworked and worked penetrations.

1.2 Unworked penetrations do not generally represent the consistency of greases in use as effectively as do worked penetrations. The latter are usually preferred for inspecting lubricating greases.

1.3 The values in SI units are to be regarded as the standard. The values given in parentheses are for information only. In the United States, the equipment dimensions stated in inches are to be regarded as the standard.

1.4 *This standard does not purport to address all of the safety concerns, if any, associated with its use. It is the responsibility of the user of this standard to establish appropriate safety, health, and environmental practices and determine the applicability of regulatory limitations prior to use.*

1.5 *This international standard was developed in accordance with internationally recognized principles on standardization established in the Decision on Principles for the Development of International Standards, Guides and Recommendations issued by the World Trade Organization Technical Barriers to Trade (TBT) Committee.*

¹ These test methods are under the jurisdiction of ASTM Committee D02 on Petroleum Products, Liquid Fuels, and Lubricants and is the direct responsibility of Subcommittee D02.G0.02 on Consistency and Related Rheological Tests.

In the IP, this test method is under the jurisdiction of the Standardization Committee. This test method has been approved by the sponsoring committee and accepted by the cooperating societies in accordance with established procedures.

Current edition approved June 1, 2020. Published September 2020. Originally approved in 1956. Last previous edition approved in 2020 as D1403 – 20a. DOI: 10.1520/D1403-20B.

2. Referenced Documents

2.1 *ASTM Standards:*²

D217 Test Methods for Cone Penetration of Lubricating Grease

D4175 Terminology Relating to Petroleum Products, Liquid Fuels, and Lubricants

2.2 *Energy Institute Standard:*³

IP 50 Method of Testing for Cone Penetration of Lubricating Grease

3. Terminology

3.1 *Definitions:*

3.1.1 *consistency, n*—of lubricating grease, the degree of resistance to movement under stress.

3.1.1.1 *Discussion*—The term consistency is used somewhat synonymously with penetration. Generally, consistency refers to the worked penetration of a grease. **D217**

3.1.2 *lubricant, n*—any material interposed between two surfaces that reduces the friction or wear between them. **D4175**

3.1.3 *lubricating grease, n*—a semi-fluid to solid product of a dispersion of a thickener in a liquid lubricant.

3.1.3.1 *Discussion*—The dispersion of the thickener forms a two-phase system and immobilizes the liquid lubricant by surface tension and other physical forces. Other ingredients imparting special properties are often included. **D217**

3.1.4 *penetration, n*—of lubricating grease, the depth that the standard cone, when released to fall under its own weight for 5 s, enters the sample.

3.1.5 *penetrometer, n*—an instrument that measures the consistency or hardness of semiliquid to semisolid materials by

² For referenced ASTM standards, visit the ASTM website, www.astm.org, or contact ASTM Customer Service at service@astm.org. For *Annual Book of ASTM Standards* volume information, refer to the standard's Document Summary page on the ASTM website.

³ Available from Energy Institute, 61 New Cavendish St., London, WIG 7AR, U.K., <http://www.energyinst.org.uk>.

*A Summary of Changes section appears at the end of this standard

measuring the depth to which a specified cone or needle under a given force falls into the material.

3.1.5.1 *Discussion*—Either a ¼-scale cone (A1.1) or a ½-scale cone (A1.3) can be used to determine the consistency of lubricating greases. The penetration forces are determined by the respective masses of the cones and shafts.

3.1.6 *reduced-scale penetration, n—of lubricating grease*, the depth in units of 0.1 mm that a ¼-scale cone or ½-scale cone penetrates the sample when released to fall under its own weight for 5 s.

3.1.6.1 *Discussion*—The term reduced-scale penetration is similar to the term penetration found in Test Methods D217. However, due to the differences in scale, the terms are not synonymous and should not be confused.

3.1.7 *reduced-scale penetrometer, n*—an instrument similar to that shown in Fig. 1 of Test Methods D217, designed to measure the consistency or hardness of semi-liquid to semi-solid materials by measuring the depth to which the ¼-scale or the ½-scale cone falls into grease.

3.1.7.1 *Discussion*—Either a ¼-scale cone (A1.1) or a ½-scale cone (A1.3) can be used to determine the consistency of lubricating greases when the quantity of sample available for testing is limited. The penetration forces are determined by the respective masses of the cones and shafts.

3.1.8 *reduced-scale worked penetration, n—of lubricating grease*, the penetration at 25 °C (77 °F), without delay, of a sample after 60 double strokes in a ¼-scale or ½-scale grease worker.

3.1.9 *thickener, n—in lubricating grease*, a substance composed of finely divided particles dispersed in a liquid lubricant to form the product's structure.

3.1.9.1 *Discussion*—The thickener can be fibers (such as various metallic soaps) or plates or spheres (such as certain non-soap thickeners) which are insoluble or, at the most, only very slightly soluble in the liquid lubricant. The general requirements are that the solid particles be extremely small, uniformly dispersed, and capable of forming a relatively stable, gel-like structure with the liquid lubricant. **D217**

3.1.10 *unworked penetration, n*—the penetration at 25 °C (77 °F) of a sample of lubricating grease that has received only minimum disturbance in transfer to a ¼-scale or ½-scale grease worker cup or dimensionally equivalent rigid container.

3.1.11 *worked penetration, n—of lubricating grease*, the penetration at 25 °C (77 °F), without delay, of a sample after 60 double strokes in a standard grease worker.

3.1.12 *working, v*—the subsection of a lubricating grease to the shearing action of the ¼-scale or ½-scale grease worker.

4. Summary of Test Method

4.1 The reduced-scale penetration is determined at 25 °C ± 0.5 °C (77 °F ± 1 °F) by releasing the ¼-scale or ½-scale cone assembly from the penetrometer and allowing the cone to drop freely into the grease for 5 s ± 0.1 s.

5. Significance and Use

5.1 These test methods are applicable to greases of National Lubricating Grease Institute (NLGI) consistency numbers 0 to

4 and are intended for use only where the size of the sample prevents the use of Test Methods D217.

5.2 Actual reduced-scale penetration values are not used or reported. They are converted to full-scale penetration values (see Sections 9 and 10). This test method is not intended to replace the full-scale penetration as described in Test Methods D217. Precision is better in the full-scale penetration method.

5.3 Worked penetration results, after conversion to full-scale values, may be used to establish the consistency of lubricating greases within the above NLGI consistency numbers. The results obtained from these test methods are widely used for specification purposes, however, no correlation with field performance has been established.

5.4 Unworked reduced-scale penetration results provide a means of evaluating the effect of storage conditions on grease consistency.

6. Apparatus

6.1 *Reduced-Scale Penetrometer*—An instrument similar to that shown in Fig. 1 of Test Methods D217, adapted for use with the ¼-scale or ½-scale cone.

NOTE 1—Any slight binding in the instrument may produce a significant error in penetration values. Periodic check of the release mechanism, cone dimensions, and weights of cone and its movable attachments is recommended.

6.2 ¼-Scale Cone and Shaft, as specified in A1.1.

6.3 ¼-Scale Grease Worker, as specified in A1.2.

6.4 ½-Scale Cone and Shaft, as specified in A1.3.

6.5 ½-Scale Grease Worker, as specified in A1.4.

6.6 *Temperature Bath*, capable of controlling the bath temperature at 25 °C ± 0.5 °C (77 °F ± 1 °F) and designed to bring the assembled grease worker to test temperature conveniently. Examples of suitable temperature baths include a water bath, air bath, constant temperature test room, or a temperature-controlled metal block. If a water bath is to be used for samples for unworked, reduced-scale penetration, means should be provided for protecting the grease surface from water and for maintaining the air above the sample at test temperature. An air bath is preferred for bringing block greases to test temperature, but a tightly sealed container placed in a water bath will suffice.

6.7 *Spatula*, corrosion-resistant, having a stiff blade approximately 13 mm (0.5 in.) wide and convenient in length.

7. Procedure for Unworked, Reduced-Scale Penetration

7.1 *Sample*—Sufficient sample to overfill the cup of the grease worker is required. Three measurements can be obtained from one filling of the grease cup, by replacement of grease lost to the cone and repairing of the grease surface.

7.2 *Preparing Sample for Measurement*—Place the empty grease worker cup and an appropriate amount of the sample in a container in the temperature bath maintained at 25 °C ± 0.5 °C (77 °F ± 1 °F) for sufficient time to bring the temperature of the sample and the worker cup to 25 °C ± 0.5 °C (77 °F ± 1 °F). Transfer the sample, preferably in one lump, to

overfill the cup of the grease worker. Make this transfer in such a manner that the grease will be worked as little as possible. Jar the cup to drive out trapped air and pack the grease with the spatula, with as little manipulation as possible to fill the cup without air pockets. Scrape off the excess grease extending above the rim, creating a flat surface, by moving the blade of the spatula, held inclined toward the direction of motion at an angle of approximately 45°, across the rim of the cup, retaining the portion removed. Do not perform any further leveling or smoothing of the surface throughout the determination of unworked, reduced-scale penetration and determine the measurement immediately.

NOTE 2—The jarring should be as vigorous as required to remove the entrapped air without splashing the specimen from the cup. In performing these operations, a minimum of manipulation should be used, as any agitation of the grease can have the effect of applying some working effect on the unworked grease and affecting the result.

NOTE 3—Retain the grease removed from the cup in scraping for subsequent tests. Keep the outside of the rim of the cup clean so that the grease forced by the penetrometer cone to overflow the cup can be returned to the cup prior to preparing the specimen for the next test.

7.3 Cleaning Cone and Shaft—Clean the penetrometer cone carefully before each test. Bending of the cone shaft can be avoided by holding it securely in its raised position while cleaning. Do not permit grease or oil on the penetrometer shaft, as they can cause drag on the shaft assembly. Do not rotate the cone, as this can cause wear on the release mechanism.

7.4 Reduced-Scale Penetration Measurement—Place the cup on the penetrometer table, making certain that it cannot teeter. Set the mechanism to hold the ¼-scale or ½-scale cone in the zero position of the indicator dial, and adjust the apparatus carefully so that the tip of the cone just touches the surface at the center of the test sample. Watching the shadow of the cone tip is an aid to accurate setting. Release the cone shaft rapidly, and allow it to drop for 5.0 s ± 0.1 s. The release mechanism should not drag on the shaft. Gently depress the indicator shaft until stopped by the cone shaft and read the penetration to the nearest full unit (0.1 mm) from the indicator.

NOTE 4—If the indicator shaft is depressed with force, the penetration measurement may vary considerably.

7.5 Additional Testing—Make a total of three tests on the specimen, positioning the cone in the center of the specimen each time. Between each measurement, replace the grease adhering to the cone with some of the portion removed and saved earlier (7.2). The cup will need to be jarred to remove any trapped air and the surface will need to be leveled, as described in 7.2. The cone also needs to be cleaned between measurements, as described in 7.3. Report the average value of the three measurements, to the nearest 0.1 mm, as the ¼-scale or ½-scale unworked penetration of the sample.

8. Procedure for Reduced-Scale Worked Penetration

8.1 Sample—Sufficient sample to overfill the cup of the appropriate grease worker is required.

8.2 Working—Transfer sufficient specimen to the cup of the clean grease worker to fill it heaping full, mounded up about 7 mm (0.25 in.) at the center, avoiding the inclusion of air by packing with the spatula. Jar the cup from time to time as it is

being packed to remove any air inadvertently entrapped. Assemble the worker and, with the vent cock open, depress the plunger to the bottom. Close the vent cock and place the assembled worker in the temperature bath maintained at 25 °C ± 0.5 °C (77 °F ± 1 °F) until the temperature of the worker and contents are at 25 °C ± 0.5 °C (77 °F ± 1 °F). Then remove the worker from the bath and wipe off any water adhering to its surfaces. If the grease sample and equipment are already at the correct temperature before the sample is placed into the worker cup, there is no need to further stabilize the sample once it has been placed in the cup. Subject the grease to 60 full double strokes of the plunger, completed in 1 min ± 5 s, and return the plunger to its top position. Open the vent cock, remove the top and plunger, and return to the cup as much of the grease clinging to the plunger as can readily be removed. As the worked penetration of a lubricating grease can change significantly on standing, proceed in accordance with 8.3 and 8.4, immediately.

NOTE 5—If a water bath is used and if it is desired to immerse the portion of the worker above its closure, take care that the lid is watertight in order to prevent the entrance of water to the worker.

8.3 Preparing Sample for Measurement—Prepare the worked specimen in the cup for testing so that a uniform and reproducible structure of the grease will be obtained. Jar the cup sharply on the bench or floor and pack the grease down with a spatula to fill the holes left by the plunger and to remove any air pockets. Scrape off the excess grease extending above the rim of the cup, creating a flat surface, by moving the blade of the spatula, held inclined toward the direction of motion at an angle of approximately 45°, across the rim of the cup retaining the portion removed.

NOTE 6—The jarring should be as vigorous as required to remove the entrapped air without splashing the specimen from the cup. In performing these operations, a minimum of manipulation should be used, as any agitation of the grease can have the effect of increasing the working beyond the specified 60 strokes.

NOTE 7—Retain the grease removed from the cup in scraping for subsequent tests. Keep the outside of the rim of the cup clean so that the grease forced by the penetrometer cone to overflow the cup can be returned to the cup prior to preparing the specimen for the next test.

8.4 Reduced-Scale Penetration Measurement—Determine the reduced-scale penetration of the specimen three times, as described in 7.3, 7.4, and 7.5. Report the average of the three tests, to the nearest 0.1 mm, as the ¼-scale or ½-scale worked penetration of the sample.

9. Calculation

9.1 The reduced-scale penetration values obtained from the ¼-scale and ½-scale cone equipment in 7.5 shall be converted to full-scale penetrations (Test Methods D217) by the following equations:

9.1.1 ¼ Scale:

$$P = 3.75p + 24 \quad (1)$$

where:

P = full-scale cone penetration by Test Methods D217, and
 p = reduced-scale cone penetration by ¼-scale equipment.

9.1.2 ½ Scale:

$$P = 2r + 5 \quad (2)$$

where:

P = full-scale cone penetration by Test Methods **D217**, and
 r = reduced-scale cone penetration by $\frac{1}{2}$ -scale equipment.

NOTE 8—Full-scale penetration values derived from the $\frac{1}{4}$ -scale or the $\frac{1}{2}$ -scale cone may differ from those obtained using Test Methods **D217**. Parties interested in using full-scale penetration values converted from the $\frac{1}{4}$ -scale or the $\frac{1}{2}$ -scale results may use modified conversion equations when mutually agreeable.

10. Report

10.1 Do not report the reduced-scale penetration values from the $\frac{1}{4}$ -scale or the $\frac{1}{2}$ -scale cone equipment (unless specified by the user). Report only the calculated full-scale penetration values from the conversion equations in **9.1.1** and **9.1.2**.

11. Precision and Bias⁴

11.1 *Precision*—The precision of these test methods has been obtained in accordance with the requirements of Committee D02, RR:D02-1007.⁵ The precision of these test methods as determined by statistical examination of interlaboratory results is as follows:

⁴ Supporting data have been filed at ASTM International Headquarters and may be obtained by requesting Research Report RR:D02-1689. Contact ASTM Customer Service at service@astm.org.

⁵ Supporting data have been filed at ASTM International Headquarters and may be obtained by requesting Research Report RR:D02-1007. Contact ASTM Customer Service at service@astm.org.

11.1.1 *Repeatability*—The difference between two test results obtained by the same operator with the same apparatus under constant operating conditions on identical test material would, in the long run, in the normal and correct operation of these test methods, exceed the values in **Table 1** in only one case in twenty.

11.1.2 *Reproducibility*—The difference between two single and independent test results obtained by different operators working in different laboratories on identical test material would, in the long run, in the normal and correct operation of the test methods, exceed the values in **Table 2** in only one case in twenty.

11.2 *Bias*—Because there is no accepted reference material suitable for determining bias for the procedure in these test methods for measuring reduced-scale cone penetration of lubricating grease by $\frac{1}{4}$ -scale and $\frac{1}{2}$ -scale equipment, bias cannot be determined.

12. Keywords

12.1 $\frac{1}{4}$ -scale; $\frac{1}{2}$ -scale; consistency; grease; lubricating grease; penetration; penetrometer; reduced-scale penetration; unworked penetration; worked penetration

TABLE 1 Repeatability (Unconverted Units)

	$\frac{1}{4}$ -Scale Units	$\frac{1}{2}$ -Scale Units
Unworked	2	4
Worked	3	4

Document Preview

[ASTM D1403-20b](https://standards.iteh.ai/ASTM-D1403-20b)

<https://standards.iteh.ai/catalog/standards/sist/8d15a169-e5d9-4dd4-a2d7-68ee12a4e449/astm-d1403-20b>

TABLE 2 Reproducibility (Unconverted Units)

	¼-Scale Units	½-Scale Units
Unworked	21	16
Worked	18	18

ANNEX

(Mandatory Information)

A1. APPARATUS

A1.1 ¼-scale Cone and Shaft—The cone shall be made of plastic or other lightweight material with hardened steel tip of 45 to 50 Hardness, Rockwell C Scale and shall be constructed to conform to the dimensions and tolerances shown in Fig. A1.1. The shaft may be made of magnesium. The total mass of the cone and its movable attachments shall be $9.38 \text{ g} \pm 0.025 \text{ g}$. The total mass of the cone and its movable attachments may be adjusted by adding small shot to the cavity of the shaft.

A1.2 ¼-scale Grease Worker shall conform to the dimensions given in Fig. A1.2. Other methods of fastening the cover and securing the worker may be used. The worker may be constructed for either manual or mechanical operation. Design shall be such that a rate of $60 \text{ strokes} \pm 10 \text{ strokes per minute}$, with a minimum length of 14 mm (½ in.), can be maintained.

A1.3 ½-scale Cone and Shaft—The cone shall be made of steel, stainless steel, or brass with the tip of 45 to 50 Hardness, Rockwell C Scale and shall be constructed to conform to the dimensions and tolerances shown in Fig. A1.3. The shaft may be made of stainless steel. The total mass of the cone and its movable attachments shall be $37.5 \text{ g} \pm 0.050 \text{ g}$. The mass of the cone shall be $22.5 \text{ g} \pm 0.025 \text{ g}$. The mass of the movable attachments shall be $15 \text{ g} \pm 0.025 \text{ g}$.

A1.4 ½-scale Grease Worker shall conform to the dimensions given in Fig. A1.4. Other methods of fastening the cover and securing the worker may be used. The worker may be constructed for either manual or mechanical operation. Design shall be such that a rate of $60 \text{ strokes} \pm 10 \text{ strokes per minute}$, with a minimum length of 35 mm (1⅜ in.), can be maintained.

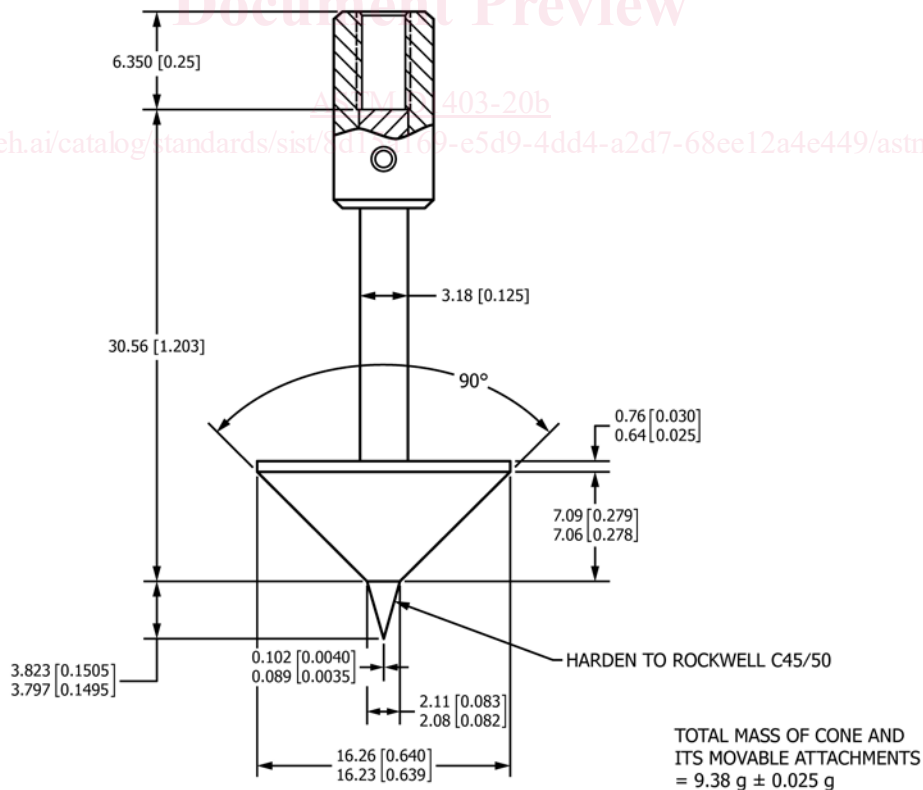

NOTE 1—All dimensions are in millimeters [inches]. Tolerance for all dimensions is $\pm 0.4 \text{ mm}$ [0.016 in.] unless otherwise specified.

FIG. A1.1 ¼-scale Cone