



Designation: C824 – 91 (Reapproved 2020)

# Standard Practice for Specimen Preparation for Determination of Linear Thermal Expansion of Vitreous Glass Enamels and Glass Enamel Frits by Dilatometer Method<sup>1</sup>

This standard is issued under the fixed designation C824; the number immediately following the designation indicates the year of original adoption or, in the case of revision, the year of last revision. A number in parentheses indicates the year of last reapproval. A superscript epsilon ( $\epsilon$ ) indicates an editorial change since the last revision or reapproval.

## 1. Scope

1.1 This practice covers the preparation of vitreous glass enamels and glass enamel frit specimens for the measurement of linear thermal expansion using Test Method E228.

1.2 The values stated in SI units are to be regarded as the standard. The values given in parentheses are for information only.

1.3 *This standard does not purport to address all of the safety concerns, if any, associated with its use. It is the responsibility of the user of this standard to establish appropriate safety, health, and environmental practices and determine the applicability of regulatory limitations prior to use.* For specific hazard statements, see Section 6.

1.4 *This international standard was developed in accordance with internationally recognized principles on standardization established in the Decision on Principles for the Development of International Standards, Guides and Recommendations issued by the World Trade Organization Technical Barriers to Trade (TBT) Committee.*

## 2. Referenced Documents

2.1 *ASTM Standards:*<sup>2</sup>

E228 Test Method for Linear Thermal Expansion of Solid Materials With a Push-Rod Dilatometer

## 3. Significance and Use

3.1 The dilatometer method of measuring linear thermal expansion of vitreous glass enamels and glass enamel frits has the advantage of simplicity, lends itself to automatic, self-recording arrangements, and requires test specimens of simple configuration.

<sup>1</sup> This practice is under the jurisdiction of ASTM Committee C14 on Glass and Glass Products and is the direct responsibility of Subcommittee C14.10 on Glass Decoration.

Current edition approved Aug. 1, 2020. Published September 2020. Originally approved in 1976. Last previous edition approved in 2015 as C824 – 91 (2015). DOI: 10.1520/C0824-91R20.

<sup>2</sup> For referenced ASTM standards, visit the ASTM website, www.astm.org, or contact ASTM Customer Service at service@astm.org. For *Annual Book of ASTM Standards* volume information, refer to the standard's Document Summary page on the ASTM website.

## 4. Apparatus

4.1 *Powder Pressing Die*, whose top and bottom sections are free to move such that density variations within the bar are minimized (see Fig. 1).

4.2 *Hydraulic Press*.

4.3 *Furnace*, for firing test specimen, electrically heated and controlled to a minimum rate of heating of 1 °C/min from room temperature to the maximum temperature of the test. It shall be so designed that the temperature variation over the length of the test specimen shall be less than 2 °C during the entire range of heating.

4.4 *Scale or Caliper*, capable of measuring the length of the test specimen to an accuracy of 0.1 %.

## 5. Reagents and Materials

5.1 *Hydroxypropyl Cellulose Solution in Water*—(1 weight %).

5.2 *Powder Sample*.

## 6. Hazards

6.1 Appropriate ventilation should be provided when handling powdered frits or enamels containing toxic ingredients.

6.2 Ingestion or inhalation of test materials should be avoided. Protective clothing such as gloves, respirators, etc., may be advisable. If ingestion occurs, seek medical attention immediately.

6.3 Caution should be exercised when placing specimens in furnaces. Tongs and insulated gloves should be used. To avoid accidental contact and serious thermal burns, care should be taken to guard hot-fired specimens while they are being cooled.

## 7. Test Specimen Preparation

7.1 Collect vitreous glass enamel or glass enamel frit particles within the 60 to 200 mesh particle size range and combine with 0.5 to 1.0 weight % of the hydroxypropyl cellulose solution.

7.2 Using the die in 4.1 and the hydraulic press in 4.2, press the powder prepared in 7.1 at 34 MPa (5000 psi) into a bar consistent with the dimensional guidelines found in Test Method E228.

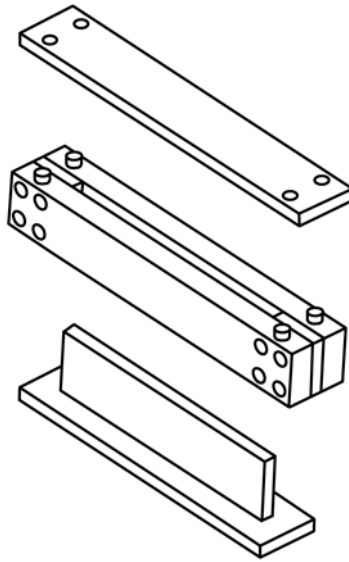

NOTE 1—Material: No. 316 stainless steel.

FIG. 1 Powder Pressing Die

7.3 Fire and anneal the test specimen prepared in 7.2 using a time/temperature cycle consistent with that used commercially for the vitreous glass enamel or glass enamel frit involved.

7.4 The ends of the fired test specimen shall conform to the guidelines given in Test Method E228.

7.5 Measure the length of the test specimen to an accuracy of 0.1 % with the test specimen at a temperature equivalent to the temperature of the dilatometer at the initiation of the test procedure (normally room temperature).

*ASTM International takes no position respecting the validity of any patent rights asserted in connection with any item mentioned in this standard. Users of this standard are expressly advised that determination of the validity of any such patent rights, and the risk of infringement of such rights, are entirely their own responsibility.*

*This standard is subject to revision at any time by the responsible technical committee and must be reviewed every five years and if not revised, either reapproved or withdrawn. Your comments are invited either for revision of this standard or for additional standards and should be addressed to ASTM International Headquarters. Your comments will receive careful consideration at a meeting of the responsible technical committee, which you may attend. If you feel that your comments have not received a fair hearing you should make your views known to the ASTM Committee on Standards, at the address shown below.*

*This standard is copyrighted by ASTM International, 100 Barr Harbor Drive, PO Box C700, West Conshohocken, PA 19428-2959, United States. Individual reprints (single or multiple copies) of this standard may be obtained by contacting ASTM at the above address or at 610-832-9585 (phone), 610-832-9555 (fax), or service@astm.org (e-mail); or through the ASTM website (www.astm.org). Permission rights to photocopy the standard may also be secured from the Copyright Clearance Center, 222 Rosewood Drive, Danvers, MA 01923, Tel: (978) 646-2600; http://www.copyright.com/*