



Designation: ~~D5048—20~~ D5048 – 20a

Standard Test Method for Measuring the Comparative Burning Characteristics and Resistance to Burn-Through of Solid Plastics Using a 125-mm Flame¹

This standard is issued under the fixed designation D5048; the number immediately following the designation indicates the year of original adoption or, in the case of revision, the year of last revision. A number in parentheses indicates the year of last reapproval. A superscript epsilon (ϵ) indicates an editorial change since the last revision or reapproval.

1. Scope*

1.1 This fire-test-response standard contains a test method for small-scale laboratory procedures to be used to determine the relative burning characteristics and the resistance to burn-through of plastics using small bar and plaque specimens exposed to a 125-mm (500-W nominal) flame.

1.1.1 Use Test Method **D3801** for assessing comparative burning characteristics of solid plastics in a vertical position.

NOTE 1—This test method is equivalent to IEC 60695-11-20 and UL 94 (Section 9).

1.2 The results are intended to serve as a preliminary indication of their acceptability with respect to flammability for a particular application. The final acceptance of the material is dependent upon its use in the end-product that conforms with the standards applicable to such end-product.

1.3 The classification system described in **Appendix X1** is intended for quality assurance and the preselection of component materials for products.

1.4 If found to be appropriate, it is suitable to apply the requirements to other nonmetallic materials. Such application is outside the scope of this technical committee.

1.5 *Fire testing is inherently hazardous. Adequate safeguards for personnel and property shall be employed in conducting these tests.*

1.6 *This standard is used to measure and describe the response of materials, products, or assemblies to heat and flame under controlled conditions, but does not by itself incorporate all factors required for fire hazards or fire risk assessment of materials, products, or assemblies under actual fire conditions.*

1.7 *This standard does not purport to address all of the safety concerns, if any, associated with its use. It is the responsibility of the user of this standard to establish appropriate safety, health, and environmental practices and determine the applicability of regulatory limitations prior to use. See 6.1.1 for a specific hazard statement.*

1.8 *This international standard was developed in accordance with internationally recognized principles on standardization established in the Decision on Principles for the Development of International Standards, Guides and Recommendations issued by the World Trade Organization Technical Barriers to Trade (TBT) Committee.*

¹ This test method is under the jurisdiction of ASTM Committee **D20** on Plastics and is the direct responsibility of Subcommittee **D20.30** on Thermal Properties. Current edition approved ~~Feb. 1, 2020~~ Sept. 1, 2020. Published ~~March 2020~~ September 2020. Originally approved in 1990. Last previous edition approved in ~~2019~~ 2020 as ~~D5048—19~~ D5048 – 20. DOI: ~~10.1520/D5048-20~~ 10.1520/D5048-20A.

*A Summary of Changes section appears at the end of this standard

2. Referenced Documents

2.1 ASTM Standards:²

D883 Terminology Relating to Plastics

D3801 Test Method for Measuring the Comparative Burning Characteristics of Solid Plastics in a Vertical Position

D5025 Specification for Laboratory Burner Used for Small-Scale Burning Tests on Plastic Materials

D5207 Practice for Confirmation of 20–mm (50–W) and 125–mm (500–W) Test Flames for Small-Scale Burning Tests on Plastic Materials

E176 Terminology of Fire Standards

E456 Terminology Relating to Quality and Statistics

E691 Practice for Conducting an Interlaboratory Study to Determine the Precision of a Test Method

E2935 Practice for Conducting Equivalence Tests for Comparing Testing Processes

2.2 IEC Standard:³

IEC 60695-11-20 Fire Hazard Testing-Part 11-20: Test Flames - 500 W Flame Test Methods

2.3 ISO Standards:⁴

ISO 13943 Fire Safety—Vocabulary

2.4 UL Standards:⁵

UL 94 Standard for Tests for Flammability of Plastic Materials for Parts in Devices and Appliances

3. Terminology

3.1 *Definitions*—For definitions of terms relating to plastics, the definitions in this test method are in accordance with Terminology D883. For terms relating to fire, the definitions in this test method are in accordance with Terminology E176 and ISO 13943. In case of conflict, the definitions given in Terminology E176 shall prevail. For terms relating to precision and bias and associated issues, the terms used in this test method are in accordance with the definitions in Terminology E456.

3.2 Definitions of Terms Specific to This Standard:

3.2.1 *flame-application time*—the time in seconds that the flame from the burner is in contact with the specimen.

3.2.2 *flaming material*—flaming drips or particles from the specimen which ignite the dry, absorbent 100 % surgical cotton placed 300 ± 10 mm below the test specimen.

3.2.3 *afterflame*—persistence of flaming of a material, after the ignition source has been removed.

3.2.4 *afterflame time*—the length of time for which a material continues to flame, under specified conditions, after the ignition source has been removed.

3.2.5 *afterglow*—persistence of glowing of a material, after cessation of flaming or, if no flaming occurs, after removal of the ignition source.

3.2.6 *afterglow time*—the length of time for which a material continues to glow under specified test conditions, after the ignition source has been removed or cessation of flaming, or both.

3.2.7 *burn-through*—a hole produced in the plaque specimen.

3.2.8 *flame*—to undergo combustion in the gaseous phase with emission of light.

3.2.9 *glow*—visible light, other than from flaming, emitted by solid undergoing combustion.

² For referenced ASTM standards, visit the ASTM website, www.astm.org, or contact ASTM Customer Service at service@astm.org. For *Annual Book of ASTM Standards* volume information, refer to the standard's Document Summary page on the ASTM website.

³ Publications of the International Electrotechnical Commission (IEC) are available from American National Standards Institute (ANSI), 25 W. 43rd St., 4th Floor, New York, NY 10036, <http://www.ansi.org>.

⁴ Available from American National Standards Institute (ANSI), 25 W. 43rd St., 4th Floor, New York, NY 10036, <http://www.ansi.org>.

⁵ Available from Underwriters Laboratories (UL), 2600 N.W. Lake Rd., Camas, WA 98607-8542, <http://www.ul.com>.

4. Summary of Test Method

4.1 Sets of 13 ± 0.5 mm by 125 ± 5 mm bar specimens and 150 ± 5 mm by 150 ± 5 mm plaque specimens are subjected to a 125 mm flame with a 40 ± 2 mm inner blue cone, for five 5-second flame applications. The afterflame plus afterglow time for the bar specimen is recorded after removal of the fifth flame application. Information is recorded on whether or not flaming material drips from the specimens, and whether or not the plaque specimens exhibit burn-through.

5. Significance and Use

5.1 The test results present afterflame plus afterglow times, in seconds, for a material under the conditions of the test. The test results for plaques also indicate whether or not the specified flame will burn through a material.

5.2 The test is capable of assessing the effects of material thickness, colors, additives, deterioration, and possible loss of volatile components on afterflame and afterglow.

5.3 The burning characteristics is found to vary with thickness. Test data shall be compared only with data for material of the same thickness.

5.4 The results serve as a reference for comparing the relative performance of materials and can be an aid in material selection.

5.5 In this test method, the specimens are subjected to one or more specific laboratory test conditions. If different test conditions are substituted or the end-use conditions are changed, it will not always be possible by or from this test method to predict changes in the fire-test-response characteristics measured. Therefore, the results are valid only for the fire-test-exposure conditions described in this test method.

6. Apparatus

6.1 *Test Chamber*, an enclosure or laboratory hood with a minimum capacity of 0.5 m^3 , free of induced or forced draft during testing. The use of an enclosed laboratory hood with a heat-resistant glass window is recommended. If a draft is noted with the exhaust fan off, further measures are needed to eliminate the draft, such as adding a positive closing damper. The inside surfaces of the chamber shall be of a dark color. When a light meter, facing towards the rear of the chamber, is positioned in place of the test specimen, the light level shall be less than 20 lx.

6.1.1 **Warning**—Products of combustion are toxic. An exhaust fan shall be provided for removing the products of combustion immediately after the test.

NOTE 2—The amount of oxygen available to support combustion is important for the conduct of flame tests. When burning times are prolonged, chamber sizes less than 1.0 m^3 do not consistently provide accurate results.

NOTE 3—Placing a mirror in the hood, to provide a rear view of the test specimen, has been found useful.

6.2 *Burner*, constructed in accordance with Specification **D5025**.

6.3 *Ring Stand*, with a clamp or the equivalent, adjustable for vertical positioning of bar specimens and horizontal positioning of plaque specimens.

6.4 *Gas Supply*—Use technical-grade methane gas (min 98 % pure) as the fuel with suitable regulator and meter for uniform gas flow.

6.4.1 The use of natural gas having an energy density of $37 \pm 1 \text{ MJ/m}^3$ (1000 Btu/ft^3) has been found to provide similar results but is not acceptable as the referee gas in cases of dispute.

6.4.2 The use of other fuel gases, such as butane, propane or acetylene is not suitable because they have higher energy per unit volume.

6.5 *Burner Mounting Fixture*, a fixture capable of positioning the burner at an angle of $20 \pm 5^\circ$ from the vertical.

- 6.6 *Timing Device*, stop watch or other suitable timing device capable of timing to the nearest 0.5 seconds.
- 6.7 *Cotton*, a supply of dry, absorbent 100 % surgical cotton.
- 6.8 *Desiccator*, containing anhydrous calcium chloride or other suitable drying agent, capable of maintaining a relative humidity not exceeding 20 % at $23 \pm 2^\circ\text{C}$.
- 6.9 *Conditioning Room or Chamber*, capable of being maintained at $23 \pm 2^\circ\text{C}$ and a relative humidity of $50 \pm 10 \%$.
- 6.10 *Conditioning Oven*, a full-draft circulating air oven capable of being maintained at $70 \pm 2^\circ\text{C}$.
- 6.11 *Micrometer*, capable of being read to 0.01 mm.
- 6.12 *Weighing Scale or Balance*, having an accuracy and resolution of 0.01 g.
- 6.13 *Flame Clearance Gauge*, (optional) used to determine flame position on specimen during testing. See [Appendix X2](#).

7. Sampling

- 7.1 Unless otherwise agreed upon, the test specimen material shall be sampled in accordance with good statistical practice.

8. Test Specimens

8.1 The standard bar specimen shall be 13 ± 0.5 by 125 ± 5 mm. The standard plaque specimen shall be 150 ± 5 by 150 ± 5 mm. Bar and plaque specimens shall be in the thickness appropriate to the objectives of the determination. Do not use this test method for materials thicker than 13 mm.

8.2 Surfaces must be smooth and unbroken. Corner radius shall not exceed 1.3 mm. After any cutting operation, remove all dust and any particles from the surface; cut edges are to have a smooth finish.

8.3 Since the results of tests carried out on test specimens of different colors, thicknesses, densities, molecular masses, directions of orientation, or containing different levels or amounts of additives, fillers or reinforcements are potentially different, the additional considerations indicated in sections 8.3.1 through 8.3.2 shall apply.

8.3.1 When conducting tests on test specimens at the minimum and maximum densities, melt flows and levels of fillers or of reinforcements, the test results shall only be considered representative of the complete range, if the results yield the same burning characteristics, including the same flame test classification.

8.3.2 If the burning characteristics, including the flame test classification, are not essentially the same for all specimens representing the range tested, the test results shall be considered to apply only to those materials for which the actual color, thickness, density, molecular mass, melt flow characteristics and level of additives, fillers and or reinforcements have been tested. Additional specimens shall be tested for intermediate ranges of each property.

8.4 The range of flammability characteristics is likely to be affected by the pigments and for each individual type of pigment, the flammability is likely to range between that corresponding to the highest level and that corresponding to no pigment. Testing as follows is required and is likely to cover the range of flammability performance:

- (a) contain no pigments (natural)
- (b) contain the highest level of organic pigments
- (c) contain the highest level of inorganic pigments
- (d) contain the highest level of carbon black (if carbon black is one of the additives in a pigment package)
- (e) contain pigments which are known to adversely affect flammability characteristics

9. Conditioning

9.1 Condition one set of five bar specimens and three plaque specimens for at least 48 h at a temperature of $23 \pm 2^\circ\text{C}$ and a relative humidity of $50 \pm 10\%$ prior to testing.

9.2 Condition a second set of five bar specimens and three plaque specimens in a circulating air oven for a duration of 168 h at $70 \pm 2^\circ\text{C}$, and then cool in a desiccator over anhydrous calcium chloride for at least 4 h at room temperature prior to testing. The desiccator should be capable of maintaining a relative humidity not exceeding 20% at $23 \pm 2^\circ\text{C}$.

9.3 Upon removal from the conditioning environment, specimens shall be tested within 30 minutes.

9.4 All specimens shall be tested in a laboratory atmosphere of 15 to 35°C and $\leq 75\%$ relative humidity.

9.5 Cotton shall be conditioned in the desiccator for at least 24 hours prior to use. Once removed from the desiccator, the cotton shall be used within 30 minutes.

10. Procedure

10.1 Procedure A—Test of Bar Specimens:

10.1.1 Conduct the burning test in a chamber, enclosure, or laboratory hood free of induced or forced draft.

10.1.2 Support a specimen from the upper 6 mm of the specimen, with the longitudinal axis vertical, by the clamp on the ring stand so that the lower end of the specimen is 300 ± 10 mm above a horizontal layer of cotton, approximately 50 by 50 mm, thinned to a maximum uncompressed thickness of 6 mm, maximum weight of 0.05 g to 0.08 grams.

NOTE 4—To form the horizontal layer, it is acceptable to pull a small portion (approximately 13 by 25 mm of cotton from the supply with the fingers and then thin and spread the cotton into a 50 by 50-mm square having a free-standing thickness of 6 mm.

10.1.3 Adjust the methane gas supply to the burner to produce a gas flow rate of 965 ± 30 mL/min with a back pressure of 125 ± 25 mm water. Place the burner remote from the specimen, ignite, and adjust it so that when the burner is in a vertical position, the overall height of the flame is 125 ± 10 mm, and the height of the inner blue cone is 40 ± 2 mm. Support the burner on the inclined plane of the mounting fixture so that the burner tube is positioned at $20 \pm 5^\circ$ from the vertical (see Fig. 1).

10.1.4 Apply the flame to one of the lower corners of the specimen at an angle of $20 \pm 5^\circ$ from the vertical, so that the tip of the inner blue cone is within 0 to 3 mm of the specimen edge without impinging into the specimen (see Fig. 2). Apply the flame for 5 ± 0.5 seconds and then remove the flame for 5 ± 0.5 seconds. Repeat this operation

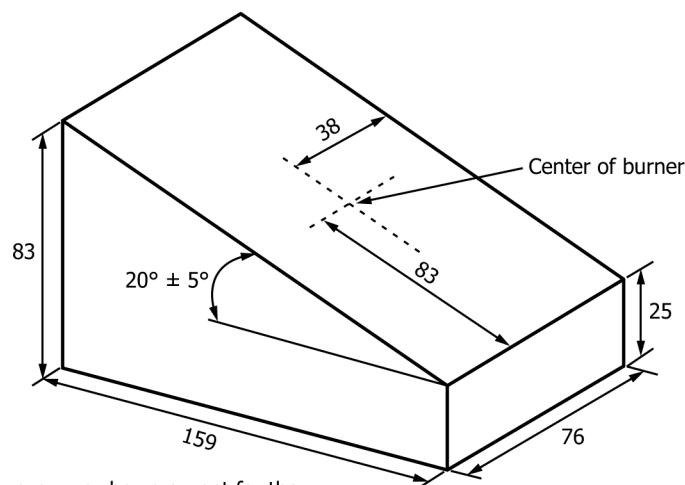

No tolerances are shown except for the angle because it is an example only.

Dimensions in millimetres

FIG. 1 Burner Mounting Block—Example

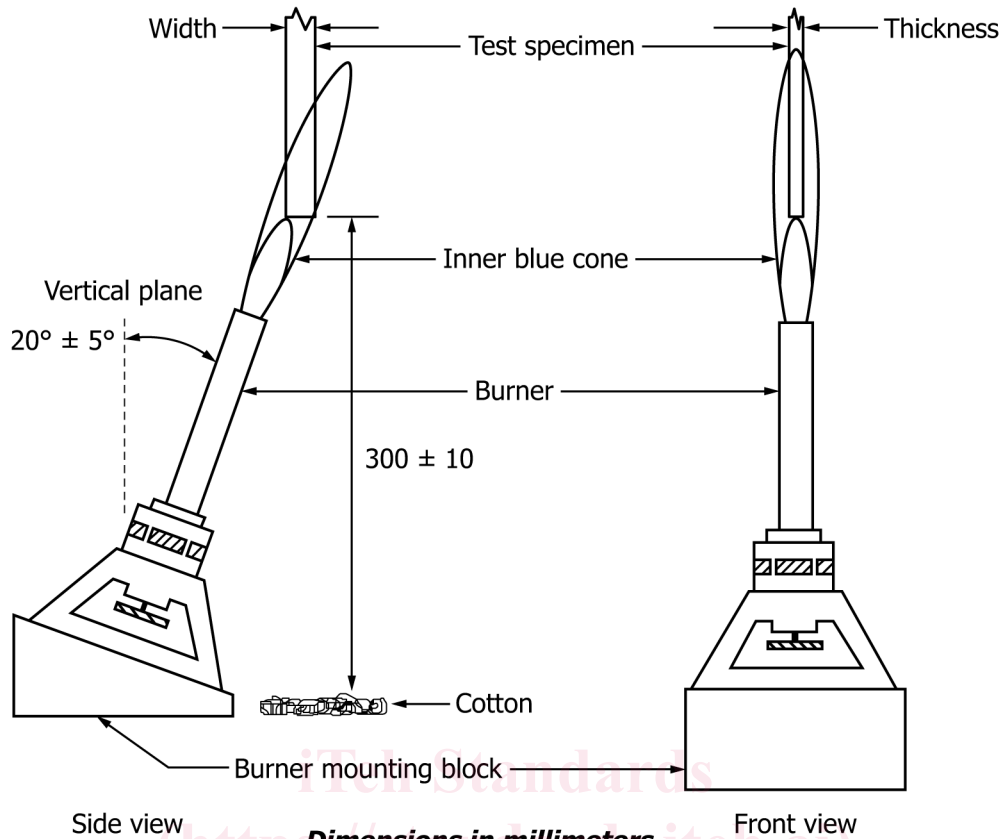

Dimensions in millimeters
FIG. 2 Procedure A—Test of Bar Specimens

until the specimen has been subjected to five applications of the test flame. After each flame application, immediately withdraw the burner a sufficient distance so that there is no thermal effect on the bar test specimen.

<https://standards.iteh.ai/catalog/standards/sist/551d0b82-d2ed-4b9c-9dbb-d71b0524d286/astm-d5048-20a>
 NOTE 5—A flame clearance gauge, pictured in Fig. X2.1, has been found helpful in correctly applying the flame in accordance with 10.1.4 and maintaining in position throughout the test.

10.1.4.1 If the specimen drips particles, shrinks, distorts or elongates during the test, move the burner so that the tip of the inner blue cone is within 0 mm – 3 mm of the corner of the bar test specimen nearest to the burner, ignoring any strings of molten material (see Fig. 3).

NOTE 6—Annex A of IEC 60695-11-20 is to be referenced for guidance.

10.1.4.2 When necessary, hand-hold the burner and fixture to accomplish this. After the fifth removal of the test flame, record, in seconds, the total afterflame time and afterflame plus afterglow times. Note whether or not the specimen dripped flaming particles that ignited the cotton.

10.1.5 Repeat the procedure in 10.1.2 – 10.1.4 on the remaining specimens for each set, one set conditioned as described in 9.1 and one set conditioned as described in 9.2.

10.1.6 Calculate the arithmetic mean of the afterflame time and afterflame plus afterglow times for each set of five specimens.

10.2 Procedure B—Test of Plaque Specimens:

10.2.1 Proceed as in 10.1.1.

10.2.2 Support a plaque specimen at its edges so that it is horizontal, using a clamp and ring stand or other equivalent means.

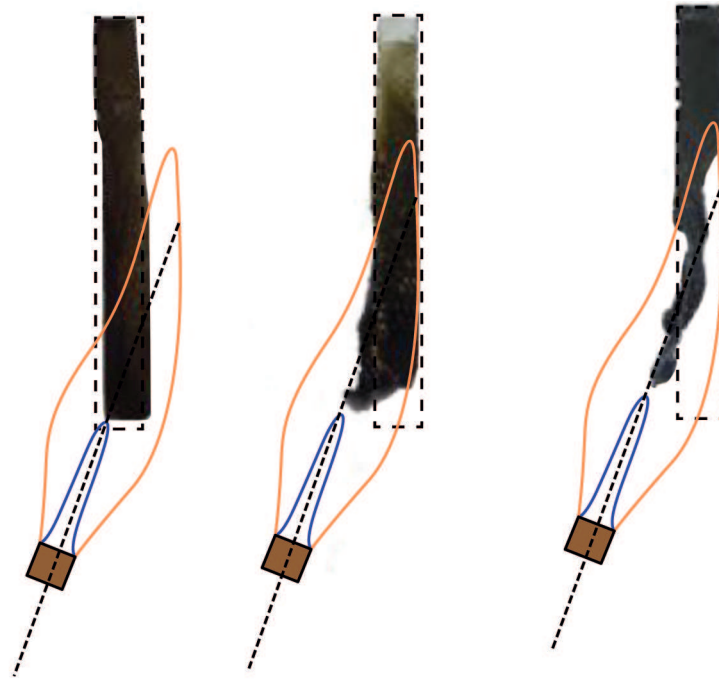

A

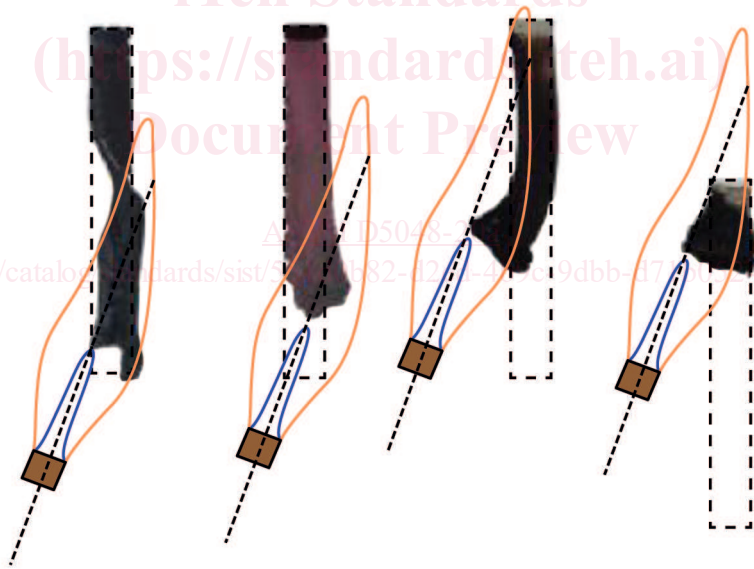

B

The examples illustrate the position of the flame at the beginning of a flame application following test specimen deformation.

FIG. 3 Examples of Flame Application

10.2.3 Proceed as in 10.1.3.

10.2.4 Apply the flame to the center of the bottom surface of the plaque at an angle of $20 \pm 5^\circ$ from the vertical so that the tip of the inner blue cone is within 0 to 3 mm of the plaque surface, without impinging into the specimen (see Fig. 4). Apply the flame for 5 ± 0.5 seconds and then remove the flame for 5 ± 0.5 seconds. Repeat this operation until the plaque has been subjected to five applications of the test flame. After each flame application, immediately withdraw the burner a sufficient distance so that there is no thermal effect on the bar test specimen.