



Designation: D1981 – 11 (Reapproved 2020)<sup>e 1</sup>

## Standard Test Method for Measuring Color After Heating of Tall Oil Fatty Acids<sup>1</sup>

This standard is issued under the fixed designation D1981; the number immediately following the designation indicates the year of original adoption or, in the case of revision, the year of last revision. A number in parentheses indicates the year of last reapproval. A superscript epsilon ( $\epsilon$ ) indicates an editorial change since the last revision or reapproval.

<sup>e 1</sup> NOTE—Editorial changes were made in subsections 7.3 and 8.3 in September 2020.

### 1. Scope

1.1 This test method covers the measurement of the Gardner color of tall oil fatty acids after heating in an atmosphere of nitrogen at 205°C for one or two hours, depending on whether its iodine value is over or under 15, respectively. The specimen may be heated using either an aluminum heating block or an oil bath. This method is applicable to all tall oil fatty acids. Applicability of this method to other types of fatty acids has not been determined.

1.2 The values stated in SI units are to be regarded as the standard. The values given in parentheses are for information only.

1.3 *This standard does not purport to address all of the safety concerns, if any, associated with its use. It is the responsibility of the user of this standard to establish appropriate safety, health, and environmental practices and determine the applicability of regulatory limitations prior to use.*

1.4 *This international standard was developed in accordance with internationally recognized principles on standardization established in the Decision on Principles for the Development of International Standards, Guides and Recommendations issued by the World Trade Organization Technical Barriers to Trade (TBT) Committee.*

### 2. Referenced Documents

2.1 *ASTM Standards:*<sup>2</sup>

**D1544** Test Method for Color of Transparent Liquids (Gardner Color Scale)

**D6166** Test Method for Color of Pine Chemicals and Related Products (Instrumental Determination of Gardner Color)

**E1** Specification for ASTM Liquid-in-Glass Thermometers

<sup>1</sup> This test method is under the jurisdiction of ASTM Committee D01 on Paint and Related Coatings, Materials, and Applications and is the direct responsibility of Subcommittee D01.34 on Pine Chemicals and Hydrocarbon Resins.

Current edition approved Sept. 1, 2020. Published September 2020. Originally approved in 1961. Last previous edition approved in 2015 as D1981 – 11 (2015). DOI: 10.1520/D1981-11R20E01.

<sup>2</sup> For referenced ASTM standards, visit the ASTM website, [www.astm.org](http://www.astm.org), or contact ASTM Customer Service at [service@astm.org](mailto:service@astm.org). For *Annual Book of ASTM Standards* volume information, refer to the standard's Document Summary page on the ASTM website.

### 3. Significance and Use

3.1 The color of a tall oil fatty acid is readily affected by heat and oxidation. Variations in degree of heat, time of heat, and exposure to atmosphere during heating have a marked effect on the color obtained; therefore, conformity to the equipment and procedure outlined in this test method is essential to accuracy and precision.

### 4. Heating Apparatus—Method A, Aluminum Block

4.1 *Forced Draft Oven*, maintained at  $205 \pm 2^\circ\text{C}$ .

4.2 *Aluminum Heating Block* (see Fig. 1). Wrap the outer surface with an appropriate insulating material.

### 5. Heating Apparatus—Method B, Oil Bath

5.1 *Oil Bath*—A 5-L steel beaker equipped with a mechanical stirrer and containing any light-colored alkali-refined oil such as hydrogenated cottonseed oil.

5.2 *Heat Source*—An electric immersion heater with suitable thermostatic control may be used. The heater shall be of sufficient capacity so that when placing several tubes in the bath, the bath temperature does not drop by more than 5°C below the minimum bath temperature and the recovery time to reach 205°C does not exceed 5 min.

5.3 *Test Tube Holder* (see Fig. 2).

### 6. Materials

6.1 *Thermometer Measuring Device*—A thermometer conforming to the requirements of Specification E1 or an electronic temperature measuring device, such as a resistance thermometer or thermocouple. The device must exhibit the same temperature response as the thermometers specified in Specification E1.

6.2 *Tubes*, 25 mm (1 in.) in diameter, 240 mm (9½ in.) in length with ground-glass joints (see Fig. 3) and adapter.

6.3 *Timer*, capable of registering up to 135 min.

6.4 *Nitrogen*, a source of nitrogen capable of being regulated to a pressure of 7 to 14 kPa (1 to 2 psi).

6.5 *Bubble Counter for Nitrogen*—As a liquid, use a portion of tall oil fatty acid, instead of water or mercury.

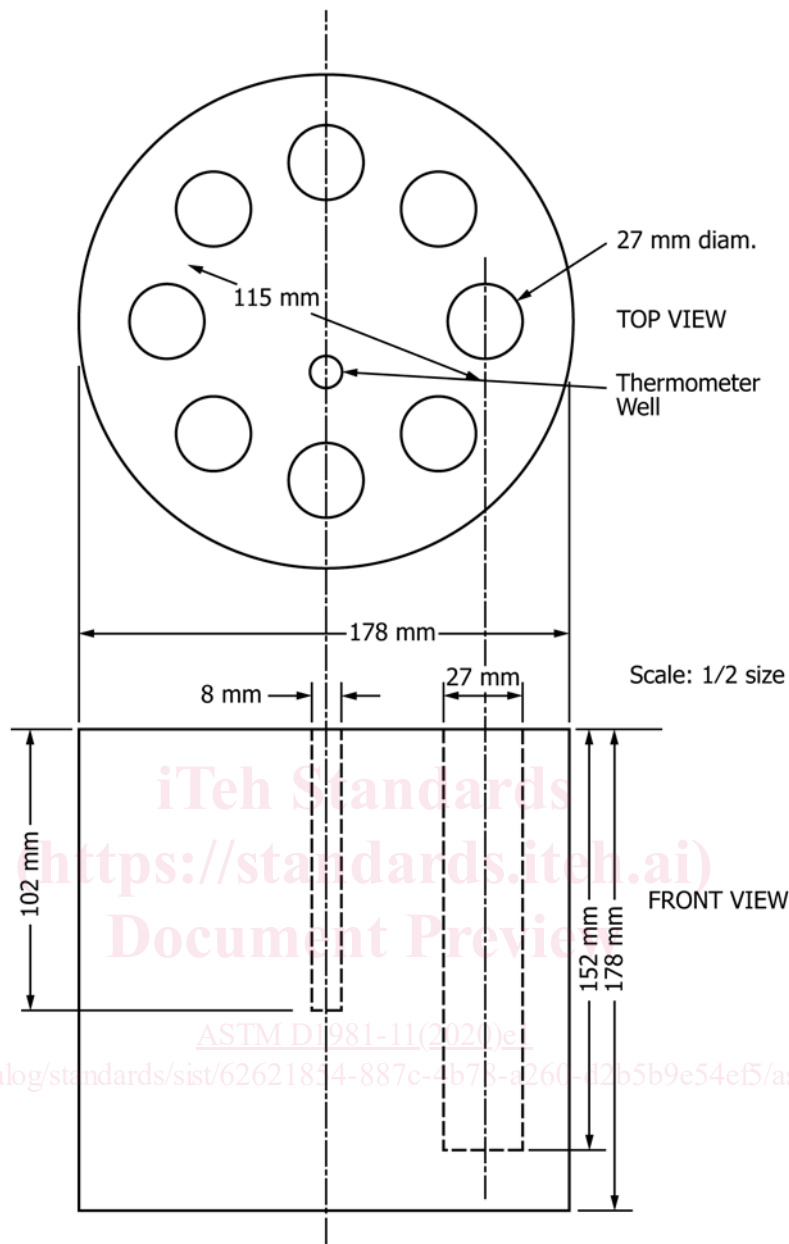

FIG. 1 Eight Hole Aluminum Heating Block

6.6 *Gardner Color Tubes or 1 cm Cuvet*—See Test Methods [D1544](#) or [D6166](#).

**7. Procedure—Method A, Aluminum Block**

7.1 Insert the thermometer into the aluminum block. Place the block in a forced-draft oven maintained at a temperature of  $205 \pm 2^\circ\text{C}$ .

7.2 Fill a clean, dry tube to a depth of approximately 125 mm with the specimen.

7.3 Place a fitted adapter in each tube. Adjust the flow of nitrogen through the side arm of the adapter at a rapid rate for 3 to 5 min to displace the air, then reduce the flow to a gentle rate of 2 or 3 bubbles per second so that the surface of the specimen is blanketed by nitrogen at all times. Place the tube

in one of the wells of the heating block. The temperature of the block should not drop more than  $5^\circ\text{C}$  when the specimens are placed in it. Once the temperature is at  $205 \pm 2^\circ\text{C}$ , set the timer for 75 min if the specimen has an iodine value greater than 15, or for 135 min if the specimen has an iodine value of 15 or less.

NOTE 1—The extra 15 min heating time is specified to allow the specimen in the block to reach the prescribed temperature.

7.4 At the end of the applicable time remove the tubes from the block while still allowing the nitrogen to flow. Cool the contents of the tubes slightly in a water-bath before removing the stoppers. Immediately fill a Gardner color tube or 1 cm cuvet with the specimen, and read the color in accordance with Test Method [D1544](#) or Test Method [D6166](#), respectively. Also measure the color of the unheated specimen.

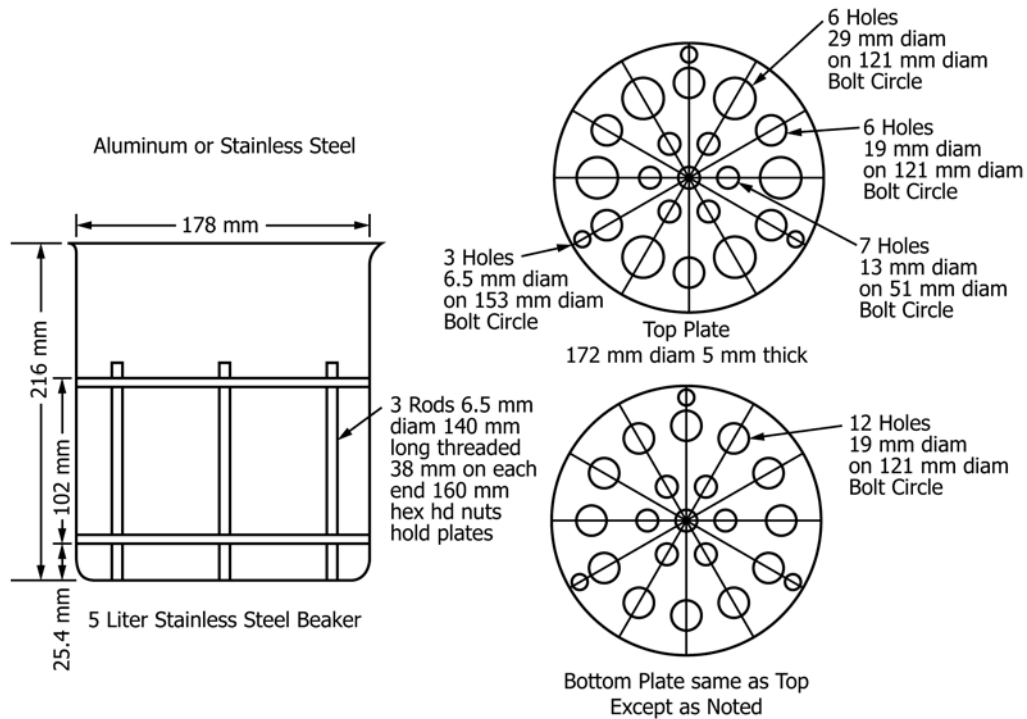

NOTE 1—1 in. = 25.4 mm.

FIG. 2 Tube Holder (Aluminum or Stainless Steel) for Color-After-Heating Test

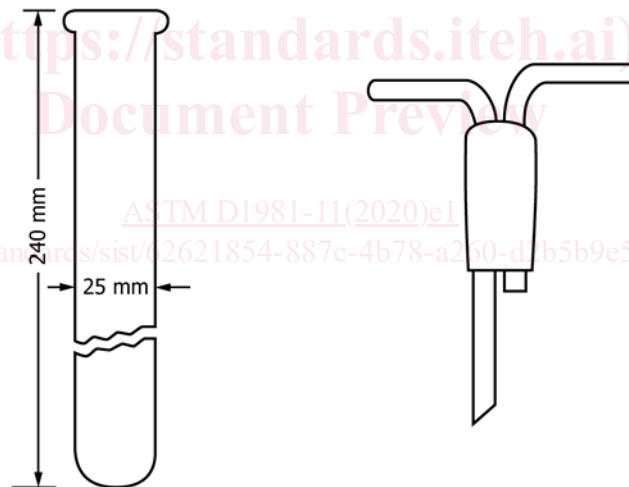

NOTE 1—1 in. = 25.4 mm.

FIG. 3 Details of Color-After-Heating Tube

## 8. Procedure—Method B, Oil Bath

8.1 Adjust the oil level so that the tubes will be immersed to a depth of 140 mm (5½ in.). Bring the bath to a temperature of  $205 \pm 2^\circ\text{C}$  and maintain the temperature within the specified range.

8.2 Fill a clean, dry tube to a depth of 127 mm (5.0 in.) with the specimen, and place it in the oil bath.

8.3 Place a fitted adapter in each tube. Adjust the flow of nitrogen through the side arm of the adapter at a rapid rate for 3 to 5 min to displace the air, then reduce the flow to a gentle

rate of 2 or 3 bubbles per second so that the surface of the specimen is blanketed by nitrogen at all times. Once the temperature is at  $205 \pm 2^\circ\text{C}$ , set the timer for 60 min if the specimen has an iodine value greater than 15, or for 120 min if the specimen has an iodine value of 15 or less.

8.4 At the end of the applicable time remove the tubes from the bath while still allowing the nitrogen to flow. Cool the contents of the tubes slightly in a water-bath before removing the stoppers. Immediately fill a Gardner color tube or 1 cm cuvet with the specimen, and read the color in accordance with