



Designation: D2670 – 20

Standard Test Method for Measuring Wear Properties of Fluid Lubricants (Falex Pin and Vee Block Method)¹

This standard is issued under the fixed designation D2670; the number immediately following the designation indicates the year of original adoption or, in the case of revision, the year of last revision. A number in parentheses indicates the year of last reapproval. A superscript epsilon (ϵ) indicates an editorial change since the last revision or reapproval.

This standard has been approved for use by agencies of the U.S. Department of Defense.

1. Scope*

1.1 This test method covers a procedure for making a preliminary evaluation of the wear properties of fluid lubricants by means of the Falex Pin and Vee Block Lubricant Test Machine.

NOTE 1—Certain fluid lubricants may require different test parameters depending upon their performance characteristics.

1.2 The values stated in inch-pound units are to be regarded as standard. The values given in parentheses are mathematical conversions to SI units that are provided for information only and are not considered standard.

1.3 *This standard does not purport to address all of the safety concerns, if any, associated with its use. It is the responsibility of the user of this standard to establish appropriate safety, health, and environmental practices and determine the applicability of regulatory limitations prior to use.*

1.4 *This international standard was developed in accordance with internationally recognized principles on standardization established in the Decision on Principles for the Development of International Standards, Guides and Recommendations issued by the World Trade Organization Technical Barriers to Trade (TBT) Committee.*

2. Referenced Documents

2.1 *ASTM Standards:*²

B16/B16M Specification for Free-Cutting Brass Rod, Bar and Shapes for Use in Screw Machines

¹ This test method is under the jurisdiction of Committee D02 on Petroleum Products, Liquid Fuels, and Lubricants and is the direct responsibility of Subcommittee D02.L0.11 on Tribological Properties of Industrial Fluids and Lubricants.

This test method was prepared under the joint sponsorship of the American Society of Lubrication Engineers. Accepted by ASLE in May 1967.

Current edition approved Sept. 1, 2020. Published September 2020. Originally approved in 1967. Last previous edition approved in 2019 as D2670 – 19. DOI: 10.1520/D2670-20.

² For referenced ASTM standards, visit the ASTM website, www.astm.org, or contact ASTM Customer Service at service@astm.org. For *Annual Book of ASTM Standards* volume information, refer to the standard's Document Summary page on the ASTM website.

3. Terminology

3.1 *Definitions of Terms Specific to This Standard:*

3.1.1 *actual gauge load, n*—the value obtained from the gauge while running the test and before any corrections are made.

3.1.1.1 *Discussion*—The gauge reading is irrespective of the particular gauge used, and corrections are made by comparison to a standard reference.

3.1.2 *direct load, n*—the load that is applied linearly, bisecting the angle of the vee block corrected to either the 800 lbf or 3000 lbf gauge reference.

3.1.2.1 *Discussion*—This load is equivalent to the true load times the $\cos 42^\circ$.

3.1.3 *true load, n*—the sum of the applied forces normal to the tangents of contact between the faces of one vee block and the journal pin corrected to the 4500 lbf gauge reference line.

3.1.4 *wear teeth, n*—a measurement of wear, which in this test, is based on the number of ratchet wheel teeth advanced during the test while maintaining load.

3.1.4.1 *Discussion*—The number of teeth is directly related to the total wear (inches).

4. Summary of Test Method

4.1 The test consists of running a rotating steel journal against two stationary steel V-blocks immersed in the lubricant sample. Load is applied to the V-blocks and maintained by a ratchet mechanism. Wear is determined and recorded as the number of teeth of the ratchet mechanism advanced to maintain load constant during the prescribed testing time.

5. Significance and Use

5.1 This test method may be used to determine wear obtained with fluid lubricants under the prescribed test conditions. The user of this test method should determine to his or her own satisfaction whether results of this test procedure correlate with field performance or other bench test machines. If the test conditions are changed, wear values may change and relative ratings of fluids may be different.

*A Summary of Changes section appears at the end of this standard

6. Apparatus

6.1 *Falex Pin and Vee Block Lubricant Test Machine*,³ illustrated in Figs. 1-3.

7. Reagents and Materials

7.1 *Required for Calibration of Load Gauge:*

7.1.1 *Allen Screw*, with attached 10 mm Brinell ball.⁴

7.1.2 *Back-Up Plug*.⁴

7.1.3 *Standard Test Coupon*,⁴ soft, annealed copper, HB 37 to 39.

7.1.4 *Brinell Microscope*, or equivalent,

7.1.5 *Timer*, graduated in seconds and minutes, and

7.1.6 *Rule*, steel, 6 in. (approximately 150 mm) long.

7.2 *Required for Test:*⁴

7.2.1 *Standard Coined V-Blocks*,⁴ $96^\circ \pm 1^\circ$ angle, AISI C-1137 steel HRC 20 to 24, surface finish 5 $\mu\text{in.}$ to 10 $\mu\text{in.}$ (1.3×10^{-7} m to 2.5×10^{-7} m), rms,

7.2.2 *Standard Test Journals*,⁴ $\frac{1}{4}$ in. (6.35 mm) outside diameter by $1\frac{1}{4}$ in. (31.75 mm) long, AISI 3135 steel, HRB 87 to 91 on a ground flat surface, surface finish 5 $\mu\text{in.}$ to 10 $\mu\text{in.}$, (1.3×10^{-7} to 2.5×10^{-7} m), rms,

7.2.3 *Locking Pins*,⁴ $\frac{1}{2}$ H brass, conforming to Specification B16/B16M.

7.2.4 *Timer*, graduated in seconds and minutes.

7.2.5 *Solvent*, safe, nonfilming, nonchlorinated.

NOTE 2—Petroleum distillate and benzene, formerly used as solvents in

³ The sole source of supply of the apparatus (Falex Pin and Vee Block Test Machine) known to the committee at this time is Falex Corp., 1020 Airpark Dr., Sugar Grove, IL 60554. A new model of this machine has been available since 1983. Certain operating procedures are different for this new model. Consult the instruction manual of machine for this information. If you are aware of alternative suppliers, please provide this information to ASTM International Headquarters. Your comments will receive careful consideration at a meeting of the responsible technical committee,¹ which you may attend.

⁴ The sole source of supply of the apparatus known to the committee at this time is Falex Corp., 1020 Airpark Dr., Sugar Grove, IL 60554. If you are aware of alternative suppliers, please provide this information to ASTM International Headquarters. Your comments will receive careful consideration at a meeting of the responsible technical committee,¹ which you may attend.

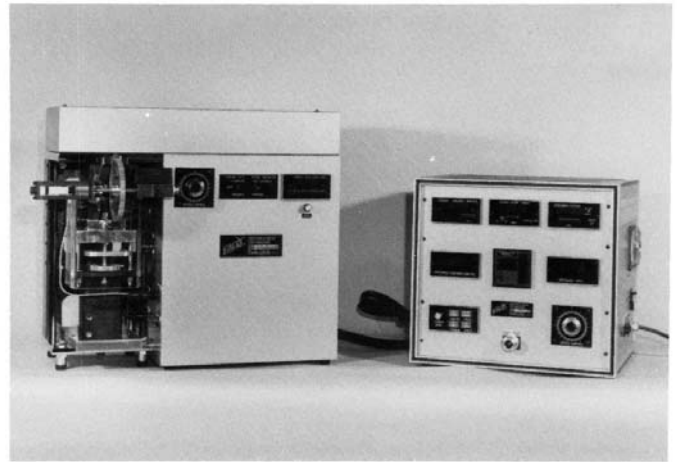

FIG. 2 Falex Digital Pin and Vee Block Test Machine

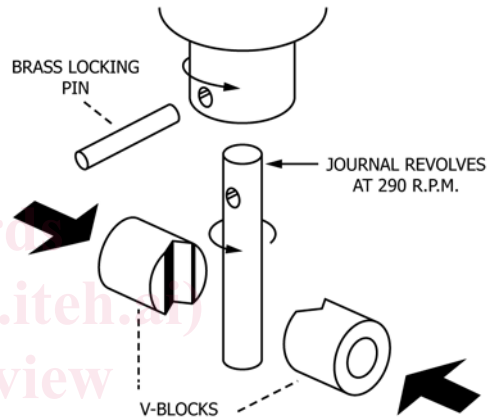

FIG. 3 Exploded View of V-Blocks and Journal Arrangement, Falex Pin and Vee Block Lubricant Test Machine

this test method, have been eliminated due to possible toxic effects. Each user should select a solvent that can meet applicable safety standards and still thoroughly clean the parts.

8. Calibration of Load Gauges

NOTE 3—Since 1992, the manufacturer uses an electronic system for calibrating load replacing the copper indentation method for calibration. This eliminates the requirement of an interpolating chart. The electronic system used by the manufacturer is traceable to NIST standards. Older style dial gauges are calibrated similarly to the copper coupon indentation method, except that the actual value is displayed on the calibration device. Newer electronic loading mechanisms can be calibrated to match the actual load displayed on the calibration fixture eliminating the need for interpolation of the gauge load value.

8.1 *Apparatus with 800 lb or 3000 lb Gauge:*

8.1.1 Remove the Allen set screw and $\frac{1}{2}$ in. (12.70 mm) ball from the left jaw socket (Fig. 4).

8.1.2 Insert the special Allen screw with the attached 10 mm Brinell ball into the working face of the left jaw. Adjust so that ball projects about $\frac{5}{32}$ (approximately 4 mm) from face of jaw.

8.1.3 Insert the back-up plug in the counterbore of the right-hand jaw. Adjust so that the plug projects about $\frac{1}{32}$ in. (approximately 0.8 mm) from the face.

8.1.4 Support the standard test coupon so that the upper edge of the coupon is about $\frac{3}{32}$ in. (approximately 2.5 mm)

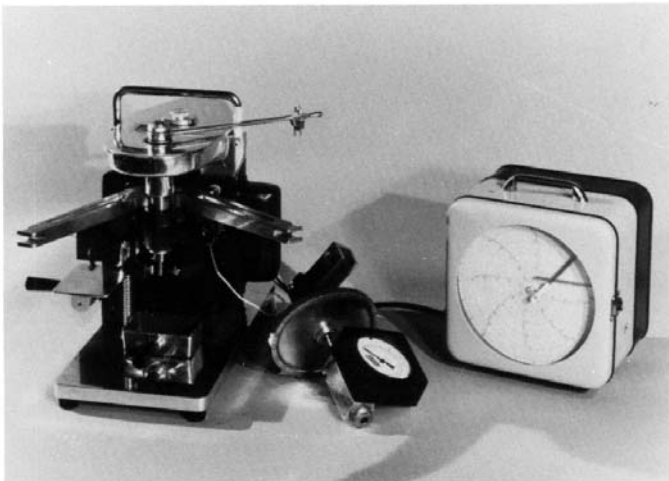

FIG. 1 Falex Pin and Vee Block Test Machine

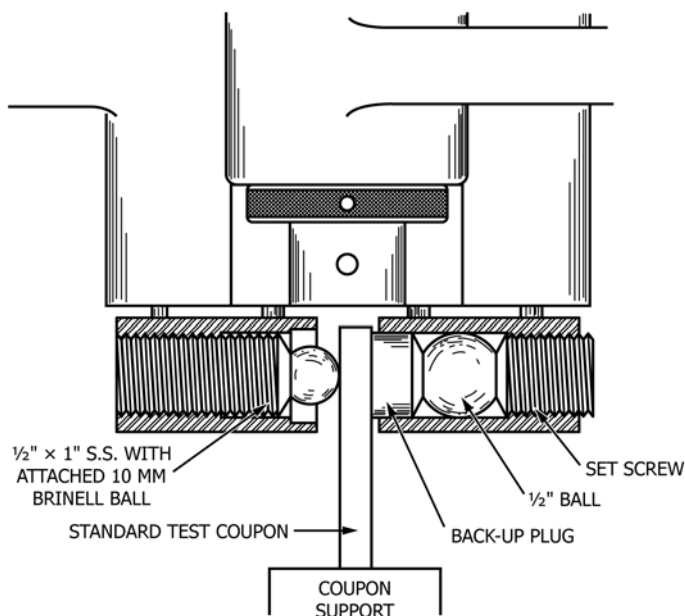

FIG. 4 Schematic Drawing of Calibration Accessories for Falex Pin and Vee Block Lubricant Test Machine

below the upper surface of the jaws. Place a steel rule across the face of the jaws. Adjust the Allen screw with the attached 10 mm ball until the face of the jaws are parallel to the steel rule with the test coupon in position for indentation.

8.1.5 With the test coupon in position for the first impression, place the load gauge assembly on the lever arms.

8.1.6 Place the loading arm on the ratchet wheel and actuate the motor. Allow the motor to run until the load gauge indicates a load of 200 lb. A slight takeup on the ratchet wheel is required to hold the load due to the ball sinking into the test coupon. After a 200 lb load is obtained, hold for 1 min for the indentation to form.

8.1.7 Turn off the machine and back off the load until the test coupon is free from the jaws. Advance the test coupon approximately 3/8 in. (approximately 9.5 mm) (additional indentations should be separated by a minimum distance of 2.5× the diameter of the initial indentation). Check the alignment of the jaws, and repeat the procedure described in 8.1.6 at gauge loads of 400 lb, 600 lb, and 800 lb when using an 800 lb gauge. If a 3000 lb gauge is used, check at 800 lb, 1500 lb, and 2500 lb.

8.1.8 Remove the load gauge assembly and test coupon and measure the diameter of each indentation to 0.01 mm with a microscope. Make three measurements of the indentation diameter, rotating the test coupon to ensure that no two measurements represent the same points. Average the three measurements of each impression and record.

8.1.9 Plot the four impression readings versus gauge load readings on log-log paper (K and E 467080 or equivalent). From the plot determine the gauge load reading corresponding to an impression diameter of 3.30 mm. Typically, this gauge load reading will be about 700 lb. This gauge load shall be used in Section 13. A typical plot of impression diameter versus gauge readings is shown in Fig. 5.

8.2 Apparatus with 4500 lb Gauge—Use the same procedure as with 800 lb gauge, above, except obtain impressions at

gauge readings of 300 lb, 500 lb, 750 lb, and 1000 lb. Plot the impression readings and determine the gauge load corresponding to an impression diameter of 3.30 mm. Typically, this gauge load reading will be about 900 lb. This gauge load shall be used in the procedure, (Section 13). Fig. 5 includes a typical plot of impression diameter versus gauge readings for the 4500 lb gauge.

9. Test Standards Check

9.1 Prepare a blend containing 0.10 % by mass of sulfur, precipitated powder, USP, and 99.90 % by mass white mineral oil,⁵ USP, having a viscosity at 100 °F (37.8 °C) of 340 to 390 SUS (73.4 to 84.2 cSt). Heat the blend, in a glass beaker, to 240 °F to 250 °F (116 °C to 121 °C) and stir (glass stirrer) for 15 min. Designate this mixture as Blend A.

9.2 Prepare, similarly, a blend containing 0.20 % by mass of sulfur and 99.80 % by mass of white mineral oil. Designate this mixture as Blend B.

9.3 Refer to Section 10 for recommended use of these standards.

10. Apparatus and Testing Check

10.1 The purpose of this check is to establish that the apparatus is in satisfactory condition and that the test is being run in conformance to the procedure covered in Section 13. For such check purposes the fluid standards covered in Section 9 should be used (Note 4). The average of triplicate runs on the fluid standards should fall within the following limits (Note 5):

Blend	Total Teeth Wear, avg. of triplicate runs
A	36 to 71
B	101 to 127

⁵ Available from most petroleum refining companies. Also available from most drug stores, typically labeled White Mineral Oil Extra Heavy. See Table X1.1 for specific products found satisfactory in cooperative test work.

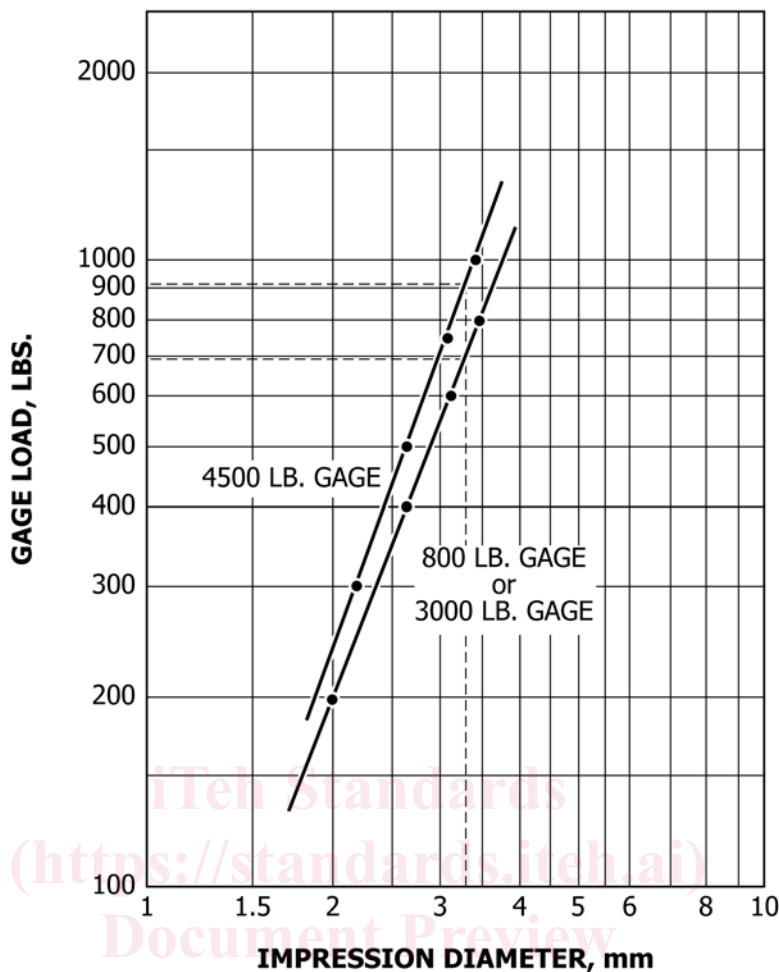

FIG. 5 Typical Curves of Gauge Load Readings versus Impression Diameter, Using 800 lb, 3000 lb, and 4500 lb Gauges and BHN 37 to 39 Standard Test Coupons

Repeatability of test data should conform to precision limits set forth in Section 15.

NOTE 4—Three commercial cutting oils were initially chosen as reference fluid standards. These were replaced by the specified white oil-sulfur blends because of greater availability, uniformity, and purity. Results of the cooperative tests on the cutting oils are covered in Appendix X1.

NOTE 5—These limits were derived from data in Appendix X1. The limits shown for Blend A are the minimum and maximum averages obtained in the Series 2 tests. Essentially the same averages were obtained in the Series 1 and 3 tests.

The limits shown for Blend B are the minimum and maximum averages obtained in the Series 1 tests. Essentially the same averages were obtained in the Series 3 tests.

11. Test Conditions

11.1 The test shall be conducted under the following conditions (Note 6):

Oil temperature at start of test	75 °F ± 10 °F (24 °C ± 3 °C)
Speed	290 r/min ± 10 r/min
Gauge load	corresponding to 3.30 mm diameter impression on standard test coupon
Duration of test	15 min ± 5 s

NOTE 6—Although the test can be run under other test conditions, the

precision limits described in Section 14 apply only to tests conducted under the conditions shown above and the procedure specified in Section 13.

12. Preparation of Apparatus

12.1 Thoroughly clean the V-blocks, test journals, lubricant cup, and supports for V-blocks and test journals by washing with the solvent selected in 7.2.5. Dry the V-blocks, test journals, lubricant cup, and supports, by allowing the solvent to evaporate in air.

12.2 After cleaning, handle the test pieces with care to prevent contamination. Particularly, avoid contact of fingers with mating surfaces of V-blocks and test journals.

13. Procedure

13.1 Insert the test journal in the test shaft and secure with a new brass locking pin, as shown in Figs. 1-3.

13.2 Insert the V-blocks into the recesses of the loading device and swing the V-blocks inward to contact the journal so that the V-grooves are aligned with the journal major axis, as shown in Fig. 1 and Fig. 2.