



Designation: E1675 – 20

Standard Practice for Sampling Two-Phase Geothermal Fluid for Purposes of Chemical Analysis¹

This standard is issued under the fixed designation E1675; the number immediately following the designation indicates the year of original adoption or, in the case of revision, the year of last revision. A number in parentheses indicates the year of last reappraisal. A superscript epsilon (ϵ) indicates an editorial change since the last revision or reappraisal.

1. Scope

1.1 The purpose of this practice is to obtain representative samples of liquid and steam as they exist in a pipeline transporting two-phase geothermal fluids.

1.1.1 The liquid and steam samples are collected and properly preserved for subsequent chemical analysis in the field or an off-site analytical laboratory.

1.1.2 The chemical composition data generated from the analysis of liquid and steam samples may be used for many applications important to geothermal energy exploration, development, and the long-term managed exploitation of geothermal resources. These applications include, but are not limited to, resource evaluations such as determining reservoir temperature and the origin of reservoir fluids, tracer-based measurements of production flow and enthalpy (TFT), compatibility of produced fluids with production, power generation and reinjection hardware exposed to the fluids (corrosivity and scale deposition potential), long-term reservoir monitoring during field exploitation, and environmental impact evaluations including emissions testing.

1.1.2.1 To fully utilize the chemical composition data in the applications stated in 1.1.2, specific physical data related to the two-phase discharge, wellbore, and geothermal reservoir may be required. Mathematical reconstruction of the fluid chemistry (liquid and steam) to reservoir conditions is a primary requirement in many applications. At a minimum, this requires precise knowledge of the total fluid enthalpy and pressure or temperature at the sample point. Fluid reconstruction and computations to conditions different from the sample collection point are beyond the scope of this practice.

1.2 This practice is limited to the collection of samples from two-phase flow streams at pressures greater than 70 kPa gauge (10 psig) and having a volumetric vapor fraction of at least 20 %. This practice is not applicable to single-phase flow streams such as pumped liquid discharges at pressures above

¹ This practice is under the jurisdiction of ASTM Committee E44 on Solar, Geothermal and Other Alternative Energy Sources and is the direct responsibility of Subcommittee E44.15 on Geothermal Field Development, Utilization and Materials.

Current edition approved Sept. 1, 2020. Published September 2020. Originally approved in 1995. Last previous edition approved in 2012 as E1675 – 04 (2012). DOI: 10.1520/E1675-20.

the flash point or superheated steam flows. Refer to Specification E947 for sampling single-phase geothermal fluids.

1.3 The sampling of geothermal fluid two-phase flow streams (liquid and steam) requires specialized sampling equipment and proper orientation of sample ports with respect to the two-phase flow line. This practice is applicable to wells not equipped with individual production separators.

1.4 The two-phase equipment and techniques described here are often the only way to obtain representative steam and liquid samples from individual producing geothermal wells. They have been developed to address common two-phase conditions such as:

1.4.1 Unstable production flow rates that have a large degree of surging,

1.4.2 Unknown percentage of total flow that is flashed to steam or is continuously flashing through the production system,

1.4.3 Mineral deposition during and after flashing of the produced fluid in wellbores, production piping, and sampling trains,

1.4.4 Stratification of flow inside the pipeline and unusual flow regimes at the sampling ports, and

1.4.5 Insufficient flash fraction to obtain a steam sample.

1.5 This practice covers the sample locations, specialized sampling equipment, and procedures needed to obtain representative liquid and steam samples for chemical analysis.

1.6 *This standard does not purport to address all of the safety concerns, if any, associated with its use. It is the responsibility of the user of this standard to establish appropriate safety, health, and environmental practices and determine the applicability of regulatory limitations prior to use. For specific hazard statements, see Section 7.*

1.7 *This international standard was developed in accordance with internationally recognized principles on standardization established in the Decision on Principles for the Development of International Standards, Guides and Recommendations issued by the World Trade Organization Technical Barriers to Trade (TBT) Committee.*

2. Referenced Documents

2.1 *ASTM Standards*:²

E947 Specification for Sampling Single-Phase Geothermal Liquid or Steam for Purposes of Chemical Analysis

2.2 *Other Document*:

ASME Code Section VIII, Division 1(2019), Pressure Vessel Design, Fabrication and Certification³

3. Summary of Practice

3.1 Samples are collected from a pipeline carrying two-phase geothermal fluids by using a sampling separator which separates liquid and steam phases through centrifugal force. Separators are operated at or near pipeline pressure, to minimize phase changes arising from pressure drop. A fraction of the separated steam is condensed, and a fraction of the separated liquid is cooled. Portions of the condensed steam and cooled liquid are collected in appropriate sample containers for subsequent chemical analysis.

4. Significance and Use

4.1 The objective of this practice is to obtain representative samples of the steam and liquid phases as they exist in the pipeline at the sample point, without allowing steam condensation or additional liquid flashing in the separator. A significant feature of the practice is the use of a cyclone-type separator for high-efficiency phase separation which is operated at flow rates high enough to prevent significant heat loss while maintaining an internal pressure essentially the same as the pipeline pressure.

4.2 Another significant feature of the practice is to locate the sampling separator at a point on the pipeline where the two-phase flow is at least partially stratified to aid in the separation process. It is neither necessary nor possible to pass representative proportions of each phase through the sampling separator to obtain representative samples. The separator is usually attached to an appropriately oriented port to collect each specific phase – normally on top of the line for steam and at the bottom for liquid. In some cases, piping configurations can generate unusual flow regimes where the reverse is required. If the ratio of one phase to another is not extreme, it may be possible to obtain representative samples of each phase from a horizontal port on the side of the pipeline.

4.3 This practice is used whenever liquid or steam samples, or both, must be collected from a two-phase discharge for chemical analysis. This typically includes initial well-testing operations when a well is discharged to the atmosphere or routine well production when a well discharges to a fluid gathering system and power plant. The combined two-phase flow of several wells producing through a common gathering system may also be sampled in accordance with this practice.

4.4 This practice is not typically employed when individual wells produce to dedicated production separators. In these cases, the separated steam and liquid at the outlet of the

production separator is sampled in accordance with single-phase sampling methods (Specification **E947**). It may, however, be used downstream of production separators when separator efficiency is expected to be very poor. In these cases, the method is used to remove the contaminating phase from the samples being collected.

5. Sample Location

5.1 Sample locations vary and are dependent upon the gross quantities of each phase at the sample point. If sample ports are properly oriented on the two-phase pipeline, a certain degree of phase stratification will have occurred prior to sampling, facilitating further separation of the target phase through the sampling separator.

5.2 Ports are ideally located on the top and bottom of the pipeline at least eight diameters downstream and two diameters upstream of major flow disturbances such as pipe bends, reductions, valving, orifice plates, etc. (see **Fig. 1**).

5.2.1 In cases where the fluid contains substantial quantities of solid debris that may plug the sample port, the liquid port can be located at a 45° angle from the bottom, provided that a sufficient liquid phase is present.

5.2.2 If the flow regime is known, the number of ports may possibly be reduced to a single port located either on the side, top, or bottom of the two-phase pipeline. Sufficient quantities of each phase must be available at the single port to allow collection of representative steam and liquid samples.

5.2.3 The sample ports must be at least 1-in. diameter and configured with a full-open port ball or gate valve. This requirement is necessary to ensure that only a minimal pressure drop occurs through the port valve and associated piping. Scale and debris often reduce the effective inner diameter of the port, therefore smaller ports are not recommended. The port size restriction also provides a safety margin given the weight of the separator and force needed to install and remove fittings from the port.

5.3 Sample ports should never be located on side-stream piping from the main flow line unless only the side-stream fluids are to be sampled. Any changes to pressure or temperature in the side stream piping will change the steam and liquid compositions to an unknown degree.

5.3.1 Sample ports should always be located on portions of the pipeline containing flowing fluids and should never be located on portions of pipelines containing stagnant fluids. The physical and chemical composition of the pipeline fluids can change significantly from heat loss and chemical reactions in the trapped fluids.

5.4 When separate sample ports are used for liquid and vapor, the two ports should be located in the same pressure environment, whenever possible. For example, liquid and vapor sample ports should be located on the same side of a pressure drop point such as a flow control valve or orifice plate. While it is possible to correct for differences in sampling pressures between liquid and vapor samples, collection of liquid and vapor samples at the same pressure eliminates the need for any correction.

² *Annual Book of ASTM Standards*, Vol 12.02.

³ Available from American Society of Mechanical Engineers 345 E. 47th St. New York, NY 10017.

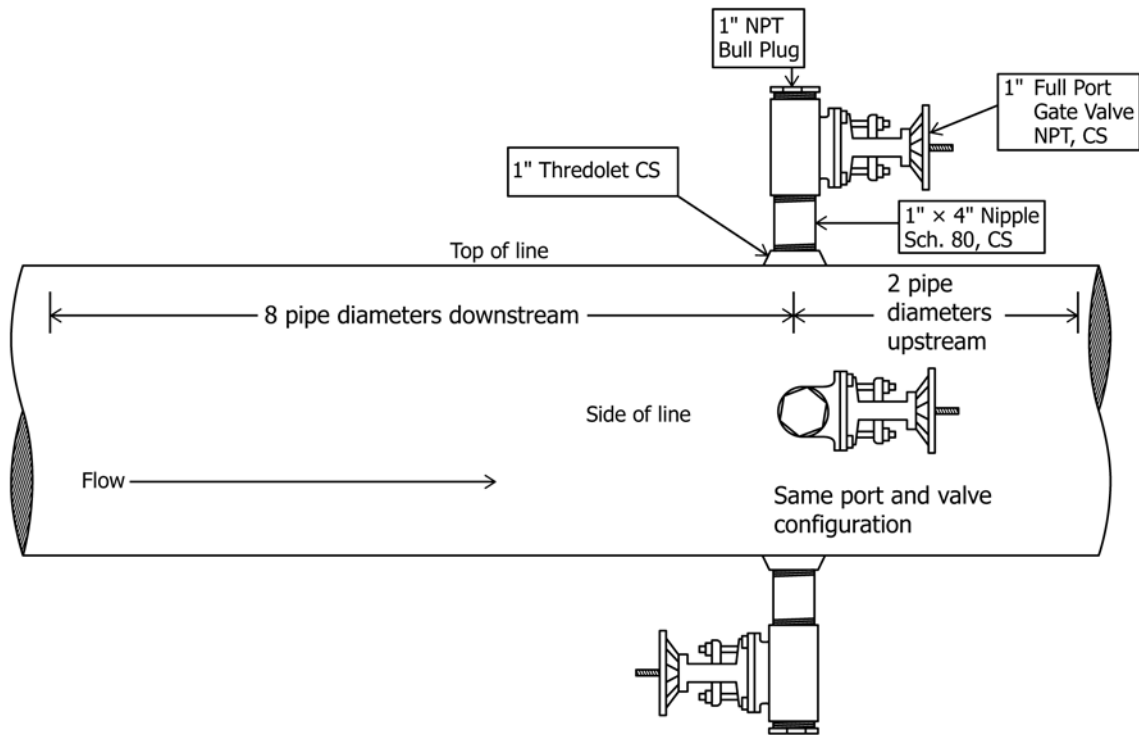

NOTE 1—Minimum pipe diameters required upstream and downstream of major flow disturbances (piping bends, reductions).

FIG. 1 Two-Phase Flowline Sampling Separator Ports

6. Equipment

6.1 *Sampling Separator*—A cyclone-type separator rated to the pipeline pressure at the sample point, including a pressure gauge, resistance temperature detector (RTD) or thermocouple probe, pressure relief device, and liquid level indicator (optional). The separator should be designed to attach directly to the sample port to minimize heat loss and pressure drop during sampling.

6.1.1 In jurisdictions requiring conformance of pressure vessel to ASME code, the separator should be designed and fabricated as a “U” stamped pressure vessel, per ASME Boiler and Pressure Vessel Code Section VIII, Division 1, and should be fabricated by a manufacturer with an ASME U Certificate of Authorization. Vessel inspection should be performed by the manufacturer in accordance with ASME BPVC Section V, and monitored by an Authorized Inspector who holds a valid commission from the National Board of Boiler and Pressure Vessel Inspectors. Other national codes, such as the Pressure Equipment Directive (PED) may be applicable in jurisdictions where ASME conformance is not required.

6.1.1.1 The separator must be rated to the maximum allowable working pressure of the pipeline to which it is connected, or a minimum of 3500 kPa gauge at 260°C (500 psig at 500°F), whichever is greater. A typical rating for a general use separator is 9225 kPa gauge at 306°C (1338 psig at 583°F). All valves, fittings, and level indicators connected to the separator must carry the same or higher pressure and temperature ratings as the vessel itself.

6.1.2 A typical sampling separator is shown in Fig. 2. This is a cyclone-type separator with a 1-in. pipe inlet attached at a tangent to the separator body. A pressure relief device (typi-

cally a rupture disc), pressure gauge and RTD or thermocouple are located at the top of the separator, and steam and liquid sample valves are located at the bottom. Steam is drawn from the top of the separator through a pipe extending up from the bottom of the vessel. Liquid is drawn directly off the bottom. Internal baffles prevent liquid films from rising up the inner walls of the vessel with the steam flow to the sample valves. Vortex breakers are placed in the bottom of the vessel to prevent steam entrainment in the liquid flow to the sample valves.

6.1.2.1 The main vent valve on the side of the sampling separator (No. 9 in Fig. 2) is used to maintain an excess flow of steam and liquid through the separator, beyond the amount needed for sample collection. If sufficient quantities of each phase are present, the side vent valve will maintain a liquid level about 50 mm (2 in.) above the liquid sample valve (No. 10 in Fig. 2). This allows collection of both steam and liquid samples from the separator without the need to adjust the liquid level.

6.1.2.2 An optional liquid level indicator can be located along one side of the separator to aid in proper separator operation and confirm the liquid level. In most applications, a liquid level indicator is unnecessary, as the separator will be configured to sample only 1 phase, and steps will be taken to eliminate the other phase.

6.1.2.3 The body of the separator is insulated with a high-temperature insulation jacket, rated to a minimum temperature of 300°C (572°F). Insulation fill material should be Pyrogel XT-E or equivalent, and should be wrapped in an outdoor weatherproof cloth, suitable of exposure to sunlight, steam, and 99 % humidity. The jacket should be fastened to the

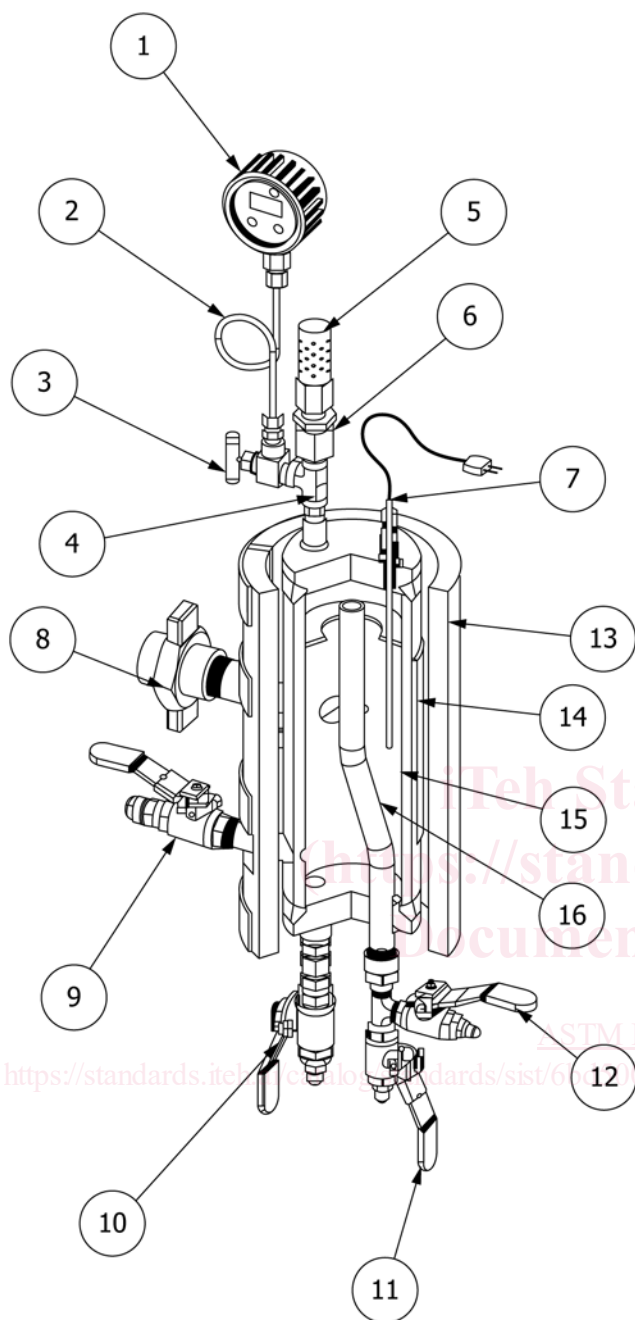

1. Digital pressure gauge (0-6.9 MPag, 0-1000 psig)
2. Loop seal
3. Pressure gauge isolation valve
4. Pressure tee
5. Pressure relief muffler
6. Rupture disk holder
7. RTD or thermocouple probe
8. 1 in. Lug union
9. 1/2 in. Main vent valve
10. 3/8 in. Liquid sample valve
11. 1/4 in. Steam monitoring vent valve
12. 1/4 in. Steam sample valve
13. Insulation jacket
14. ASME U-Stamp
15. 4 in. Separator body
16. 1/2 in. Steam outlet pipe

Material specification: All metal components made from UNS S30400, S31600, S30403, or S31603. Alternative materials, such as N06625 may be appropriate when sampling conditions are likely to cause stress corrosion cracking.

FIG. 2 Sampling Separator

separator body in such a way that it is secure, but still removable. Straps and buckles are the most common means of attachment.

6.2 Sample Hoses—Sample hoses are perfluoroalkoxy alkane (PFA) tubing with UNS S30400, S31600, S30403, or S31603 overbraid rated to 1378 kPag and 243°C (500 psig and 470°F). Joint Industry Council/Army-Navy (JIC/AN) type fittings attach hoses to the separator and condenser. Hoses are dedicated to either steam or liquid service to prevent cross-contamination.

6.2.1 The inner diameter of hose used for liquid sampling should not exceed 9.5 mm (0.375 in.).

6.2.2 The inner diameter of hose used for vapor sampling should not exceed 6.4 mm (0.250 in.).

6.2.3 When sampling pressure exceeds 1378 kPag, UNS S30400, S31600, S30403, or S31603 tubing should be used (0.25 to 0.375-in. outside diameter), although it is less convenient. Convoluted, flexible stainless steel hose is specifically excluded due to potential entrapment and contamination problems caused by the internal convolutions. Alternative materials such as N06625 may be appropriate when the fluid being sampled is likely to have high concentrations of halides.

6.3 Condenser—A sample condenser configuration with separate sets of UNS S30400, S31600, S30403, or S31603 tubing coils is required. One set of coils is dedicated for condensing steam and the other is dedicated for cooling liquid.

6.3.1 The steam condenser coil has a pressure/vacuum compound gauge (-30 in. of Hg to 30 psig is typical) located at the sample outlet and a regulating valve at the inlet. The steam flow is regulated at the inlet, as opposed to regulating the flow of condensate and gas at the outlet, which can result in large pressure surges and holdup of gas or condensate phases in the coils. The steam condenser coil tubing must not exceed 6.4 mm (0.25 in.) outside diameter to prevent the segregation of gas and condensate phases during sampling of steam.

6.3.1.1 The condenser coil is arranged as a downward spiral with the inlet at the top. This maintains the thermal gradient in the cooling container, allowing the coolant at the surface to boil and radiate as much heat as possible, while preserving the cooler fluids at the bottom of the vessel. The condensed steam exits through a straight tube rising to the top of the cooler, or in some cases, straight from the bottom of the container (see **6.3.3**).

6.3.2 The liquid cooling coil has a regulating valve at the outlet. Regulating the flow at the condenser outlet maintains pressure on the liquid as it cools, and prevents flashing of liquid inside the condenser which could result in gas break-out or chemical deposition, or both. The outside diameter of the liquid cooling coil is typically 6.4 mm (0.250 in.). In cases where the liquid contains substantial quantities of particulate matter, 9.5 mm (0.375 in.) outside diameter tubing coils may be used to minimize cooling coil plugging problems. Outside diameters larger than 9.5 mm (0.375 in.) should not be used, as larger tubing sizes increase the risk of contamination and chemical deposition during liquid sampling due to low fluid velocities and longer residence times within the tubing (see **Fig. 3** and **Fig. 4**).

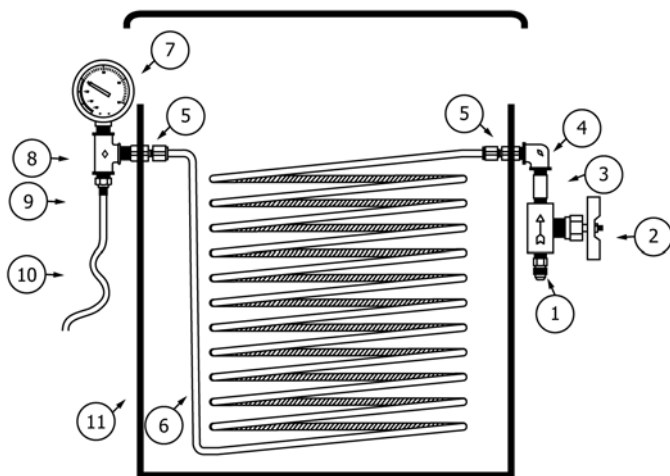

1. JIC Fitting (1/4 in. NPT × S.A.E. 37°) Sample Inlet
2. Regulating Valve (1/4 in. NPT)
3. Pipe Nipple (1/4 in. NPT)
4. Pipe Elbow (1/4 in. NPT)
5. Bulkhead Fitting (1/4 in. NPT × 1/4 in. Swagelok)
6. 20 ft. × 1/4 in. O.D. Tubing (0.035 in. wall)
7. 30 in. Hg × 30 psi Vacuum/Pressure Gauge
8. Gauge Tee (1/4 in. NPT)
9. Hose Adapter (1/4 in. NPT × 1/4 in. Hosebarb)
10. Plastic⁵ Tubing (3/8 in. O.D., 3/16 in. I.D.) Sample Outlet
11. 8- to 20-Gallon Drum with Lid

Material specification: All metal components made from UNS S30400, S31600, S30403, or S31603. Alternative materials, such as N06625 may be appropriate when sampling conditions are likely to cause stress corrosion cracking.

FIG. 3 Steam Sample Condenser

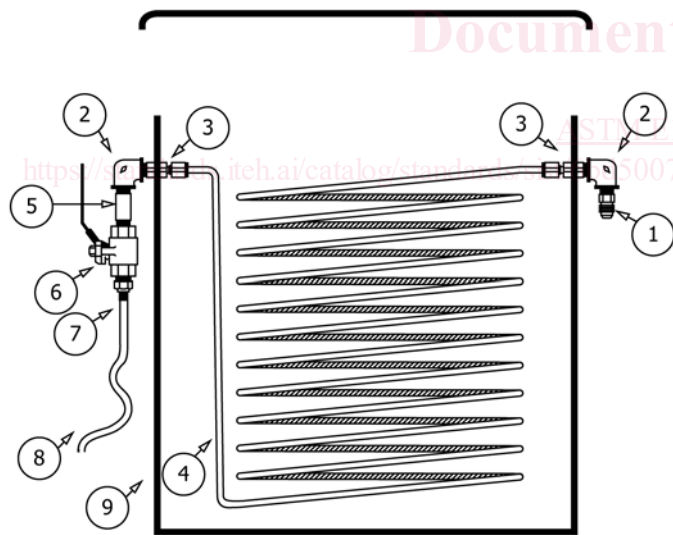

1. JIC Fitting (1/4 in. NPT × S.A.E. 37°) Sample Inlet
2. Pipe Elbow (1/4 in. NPT)
3. Bulkhead Fitting (1/4 in. NPT × 1/4 in. or 3/8 in. Swagelok)
4. 20 ft. × 1/4 in. or 3/8 in. O.D. Tubing (0.035 in. wall)
5. Pipe Nipple (3 in. × 1/4 in. NPT)
6. Sample Valve (Ball Valve, 1/4 in. NPT)
7. Hose Adapter (1/4 in. NPT × 1/4 in. Hosebarb)
8. Plastic⁵ Tubing (3/8 in. O.D., 3/16 in. I.D.) Sample Outlet
9. 8- to 20-Gallon Drum with Lid

Material specification: All metal components made from UNS S30400, S31600, S30403, or S31603. Alternative materials, such as N06625 may be appropriate when sampling conditions are likely to cause stress corrosion cracking.

FIG. 4 Liquid Sample Cooler

6.3.2.1 The brine cooling coil is arranged as a downward spiral with the inlet at the top. This maintains the thermal gradient in the cooling container, allowing the coolant at the surface to boil and radiate as much heat as possible, while preserving the cooler fluids at the bottom of the vessel. The brine exits through a straight tube rising to the top of the cooler.

6.3.3 In cases where the noncondensable gas concentration in steam exceeds approximately 5 % by weight, the outlet of the steam condenser coil should be at an elevation below the inlet with a continuous down-slope in the tubing from inlet to outlet. This allows the small volume of condensate to drain freely out of the condenser and prevents hold-up within the coils. Smaller diameter coils may be necessary if noncondensable gas concentrations exceed 5 % by weight. In these cases, tubing with an outer diameter of 3.18 mm (0.125 in.) will maintain flow velocities without excessive restriction of fluid flow.

6.3.4 Condenser cooling can be achieved by an ice/water bath surrounding the coils or by a continuous overflow of cooling water running into the vessel holding the coils (configuration shown in Fig. 3 and Fig. 4). Alternate configurations may include a water-tight jacket around the coils through which a constant source of cooling water flows. A source of coolant may be a glycol/water mixture circulated through the condenser jacket and an external fan-cooled heat exchanger.

6.4 Pressure Gauge—For the measurement of separator pressure. A digital pressure transducer should be used. A pressure-snubbing device is recommended to minimize the pressure spikes and surges common in two-phase flow lines. Minimum accuracy of the gauge should be $\pm 1\%$ of full-scale. The gauge should be calibrated at monthly intervals when in routine use and every six months for intermittent use. All gauges require permanent identification numbers so that field data and calibration data can be traced to each specific instrument.

6.5 Temperature Meter and Resistance Temperature Detector or Thermocouple Probes—For the measurement of separator temperature. Temperature meters are the digital readout style with plug-in Resistance Temperature Detector (RTD) probes or Type-K thermocouples. 4-wire RTD probes are preferred due to the large linear range and stable signal. Minimum accuracy of the meter should be at least $\pm 0.6^\circ\text{C}$ ($\pm 1^\circ\text{F}$). Meters and temperature probes should be calibrated at the same intervals as the pressure gauges to ensure consistency between the measurements of pressure and temperature. All meters and probes require permanent identification numbers so that field data and calibration data can be traced to each specific instrument.

6.6 Fittings—Sample ports on the separator often need to be replumbed, and fittings may need to be replaced. A selection of pipe fittings including reducer bushings, pipe nipples, couplings and elbows, plus those needed for sample equipment maintenance, are required on site.

6.7 Plastic⁴—Sample tubing located at the exit of the condenser for gas and liquid sample collection 4.8 mm (0.188

⁴ Tygon, a registered trademark product of Norton Co., has been used for this purpose.