



Designation: ~~D2625–94 (Reapproved 2015)~~ D2625 – 20

Standard Test Method for Endurance (Wear) Life and Load-Carrying Capacity of Solid Film Lubricants (Falex Pin and Vee Method)¹

This standard is issued under the fixed designation D2625; the number immediately following the designation indicates the year of original adoption or, in the case of revision, the year of last revision. A number in parentheses indicates the year of last reapproval. A superscript epsilon (ϵ) indicates an editorial change since the last revision or reapproval.

This standard has been approved for use by agencies of the U.S. Department of Defense.

1. ~~Scope~~ Scope*

1.1 This test method (see **Note 1**) covers the determination of the endurance (wear) life and load-carrying capacity of dry solid film lubricants in sliding steel-on-steel applications.

NOTE 1—Reference may be made to Coordinating Research Council, Inc. (CRC) Report No. 419, “Development of Research Technique for Measuring Wear Life of Bonded Solid Lubricant Coatings for Airframes, Using the Falex Tester.” See also ~~Military Specification MIL-L-8937 (ASG), SAE Aerospace Standard AS5272, Jan. 22, 1963, and Methods 3807 and 3812 of Federal Test Method 791a.~~

1.2 The values stated in SI units are to be regarded as the standard except where equipment is supplied using inch-pound units and would then be regarded as standard. The metric equivalents of inch-pound units given in such cases in the body of the standard may be approximate.

1.3 *This standard does not purport to address all of the safety concerns, if any, associated with its use. It is the responsibility of the user of this standard to establish appropriate ~~safety~~ safety, health, and ~~health~~ environmental practices and determine the applicability of regulatory limitations prior to use.*

1.4 *This international standard was developed in accordance with internationally recognized principles on standardization established in the Decision on Principles for the Development of International Standards, Guides and Recommendations issued by the World Trade Organization Technical Barriers to Trade (TBT) Committee.*

2. Referenced Documents

2.1 *ASTM Standards:*²

~~B16/B16M~~ Specification for Free-Cutting Brass Rod, Bar and Shapes for Use in Screw Machines

F22 Test Method for Hydrophobic Surface Films by the Water-Break Test

2.2 *U.S. Military Specifications:*³

~~MIL-L-8937~~

~~MIL-P-16232~~ F MIL-DTL-16232 Phosphate Coatings, Heavy, Manganese or Zinc Base ~~(for Ferrous Metals)~~

¹ This test method is under the jurisdiction of ASTM Committee D02 on Petroleum Products, Liquid Fuels, and Lubricants and is the direct responsibility of Subcommittee D02.L0.05 on Solid Lubricants.

Current edition approved July 1, 2015; Sept. 1, 2020. Published July 2015; October 2020. Originally approved in 1967. Last previous edition approved in 2010; 2015 as D2625 – 94 (2010); (2015). DOI: 10.1520/D2625-94R15.10.1520/D2625-20.

² For referenced ASTM standards, visit the ASTM website, www.astm.org, or contact ASTM Customer Service at service@astm.org. For *Annual Book of ASTM Standards* volume information, refer to the standard’s Document Summary page on the ASTM website.

³ Available from Standardization Documents Order Desk, DODSSP, Bldg. 4, Section D, 700 Robbins Ave., Philadelphia, PA 19111-5098, <http://dodssp.daps.dla.mil/https://quicksearch.dla.mil/qsSearch.aspx>.

*A Summary of Changes section appears at the end of this standard

2.3 Other Standards:

[42USC7671a Clean Air Act Amendments of 1990](#)⁴

~~Federal Test Method 791a~~ [SAE AS5272 Methods 3807 and 3812](#) [Lubricant, Solid Film, Heat Cured, Corrosion Inhibiting, Procurement Specification](#)⁵

3. Terminology

3.1 Definitions:

3.1.1 *dry solid film lubricants*—*lubricants, n*—dry coatings consisting of lubricating powders in a solid matrix bonded to one or both surfaces to be lubricated.

3.2 Definitions of Terms Specific to This Standard:

3.2.1 *direct load, n*—the load that is applied linearly, bisecting the angle of the vee block corrected to either the 800 lbf (3550 N) gauge reference or the 3000 lbf (13 300 N) gauge reference.

3.2.1.1 Discussion—

This load is equivalent to the true load times the $\cos 42^\circ$.

3.2.2 *endurance (wear) life*—*life, n*—the length of test time before failure under a constant loaded condition, in minutes, in which the applied test lubricant performs its function.

3.2.3 *gauge load, n*—the value obtained from the gauge while running the test after being corrected to the standard curve using the calibration procedure for the 4500 lbf (20 000 N) reference gauge.

3.2.3.1 Discussion—

The gauge reading is irrespective of the particular gauge used, and corrections are made by comparison to the Brinell ball impression diameters on a standard reference copper test coupon with a Rockwell hardness range of HB 37 to HB 39. An electronic calibration instrument⁶ is available which can be used in place of the copper coupon.

3.2.4 *load carrying capacity*—*capacity, n*—the highest indicated load sustained for a minimum of 1 min.

4. Summary of Test Method

4.1 The endurance test (Procedure A) consists of running two stationary steel vee block specimens loaded to a predetermined value against a rotating steel pin specimen. The endurance (wear) life is determined when the torque increases by 10 in.·lbf (1.13 N·m).

<https://standards.iteh.ai/catalog/standards/sist/f0ee23b1-5f4d-4491-b451-f4cd0839a0a6/astm-d2625-20>

4.2 The load-carrying capacity test (Procedure B) consists of running two stationary steel vee block specimens against a rotating steel pin, increasing the load on the pin until a sharp increase (10 in.·lbf (1.13 N·m)) in steady-state torque or pin breakage is experienced. Prior to both tests, the solid film lubricant is deposited on the surfaces of the test specimens.

5. Significance and Use

5.1 This test method differentiates between bonded solid lubricants with respect to their wear life and load-carrying capacity. If the test conditions are changed, wear life may change and relative ratings of the bonded solid film lubricants may be different.

6. Apparatus

6.1 *Falex Pin and Vee Block Test Machine*,⁶ ~~illustrated~~ illustrated in [Fig. 1](#) and [Fig. 2](#).

6.1.1 *Load Gauge*,⁶ ~~4500 lbf~~ 4500 lbf (20 000 N) range, or 3000 lbf (13 300 N) direct-reading gauge. An 800 lbf (3550 N) direct-reading load gauge may be used for Procedure A, but does not have a high enough load range for Procedure B.

⁴ Available from U.S. Government Printing Office Superintendent of Documents, 732 N. Capitol St., NW, Mail Stop: SDE, Washington, DC 20401, <http://www.access.gpo.gov> Environmental Protection Agency, <http://epa.gov>.

⁵ Available from SAE International (SAE), 400 Commonwealth Dr., Warrendale, PA 15096, <http://www.sae.org>.

⁶ Trademark of and available from Falex Corp., 1020 Airpark Dr., Sugar Grove, IL 60554. A new model of the Falex Pin and Vee Block Test Machine has been available since 1983. Certain operating procedures are different for this new model. Consult instruction manual of machine for this information. If you are aware of alternative suppliers, please provide this information to ASTM International Headquarters. Your comments will receive careful consideration at a meeting of the responsible technical committee,¹ which you may attend.

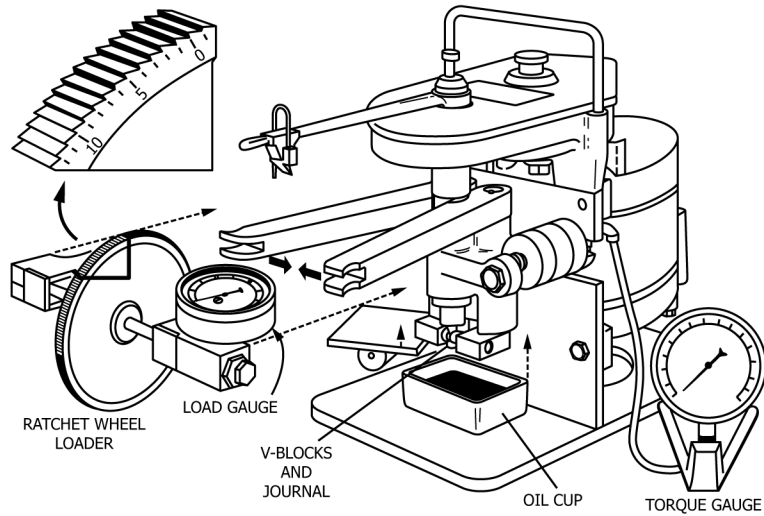

FIG. 1 Schematic Diagram of Failex Pin and Vee Block Test Machine



FIG. 1 Digital Pin and Vee Block Test Machine (continued)

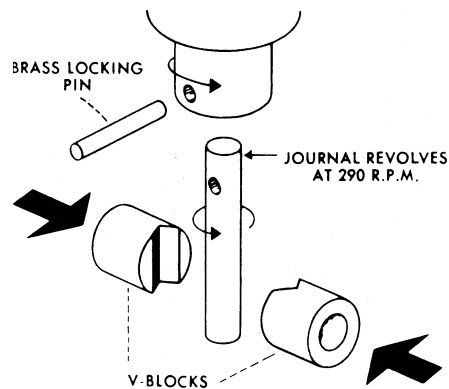

FIG. 2 Exploded View of Vee Blocks and Journal Arrangement, Failex Pin and Vee Block Test Machine

NOTE 2—Primary figures for loads are shown for the 4500 lbf (20 000 N) gauge. Equivalent readings on either 800 lbf or 3000 lbf (3550 N or 13 300 N) direct-reading gauges are shown in parentheses and can be obtained from the curve in Fig. 3.

6.1.2 *Optional*—An automatic cutoff, torque recorder, and timer may be used in place of the standard indicating torque gauge.

6.2 *Required for Calibration of Load Gauge:*

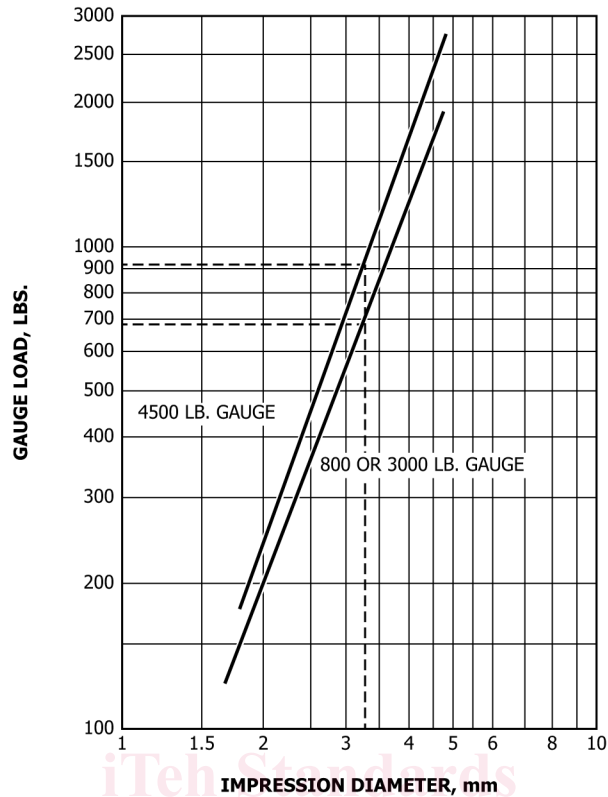

FIG. 3 Standard Curves for Load Gauge Calibration or Conversion, Brinell Impression Diameter versus Gauge Load Reading, Using Standard Copper Test Coupon of HB 37/39

- 6.2.1 Standardized Test Coupon, ⁶soft, soft, annealed copper HB 37/39.
- 6.2.2 Allen Screw, ⁶with with attached 10 mm Brinell ball.
- 6.2.3 Back-up Plug.⁶
- 6.2.4 Brinell Microscope, or equivalent.
- 6.2.5 Rule, steel, 150 mm (6 in.) long.
- 6.2.6 Timer, graduated in minutes and seconds.
- 6.3 Required for Application of Dry Solid Film Lubricants (see Annex A1):
 - 6.3.1 Desiccator, for storing test parts. The bottom of the desiccator shall be filled with desiccant to maintain approximately 50 % relative humidity. (Not required if parts can be stored in a fume-free room at 50 % ± 5 % relative humidity.)
 - 6.3.2 Forced-Circulation Oven, capable of maintaining a temperature of 149 °C ± 5 °C (300 °F ± 10 °F).
 - 6.3.3 Micrometer, reading 00 mm to 25 mm ± 0.0025 mm (0 in. to ±1 in. ± 0.0001 in.), with a one-ball anvil.
 - 6.3.4 ~~Vapor Degreasing Bath.~~ Suitable equipment for preparation and application of solid film lubricant.

7. Reagents and Materials

- 7.1 Required for Procedures A and B:

7.1.1 *Eight Standard Vee Blocks*, $96^{\circ} \pm 1^{\circ}$ angle, heat treated to 1.24×10^9 Pa to 1.38×10^9 Pa (180 000 psi to 200 000 psi) tensile strength; or standard coined vee blocks, $96^{\circ} \pm 1^{\circ}$ angle, of AISI C-1137 steel as an alternative, with a Rockwell hardness of HRC 20 to 24 and surface finish of 1.3×10^{-7} m to 2.5×10^{-7} m (5 μ m. to 10 μ m.), rms.

7.1.2 *Four Standard Test Pins*, ~~6.35 mm~~ **6.35 mm** (1/4 in.) outside diameter by 31.75 mm (1 1/4 in.) long, heat treated to 1.24×10^9 Pa to 1.38×10^9 Pa (180 000 psi to 200 000 psi) ultimate hardness; or Standard No. 8 Pins of AISI 3135 steel as an alternative, with a hardness of HRB 87 to 91, on a ground, flat surface (or approximately HRB 80 to 83 on the round), and a surface finish of 1.3×10^{-7} m to 2.5×10^{-7} m (5 μ m. to 10 μ m.) rms.

7.1.3 *Locking (Shear) Pin*, ~~1/2-H~~ **H** Brass, conforming to Specification **B16/B16M**.

7.2 *Required for Application of Dry Solid Film Lubricant* (see **Annex A1**):

7.2.1 *Phosphate Coating*, ~~manganese~~, **manganese**, conforming to Military Specification ~~MIL-P-16232F~~, **MIL-DTL-16232**, Type M, Class 3 controlled to a coating weight of 16 g/m² to 22 g/m².

NOTE 3—Lack of rigid control of the phosphate coating weight can significantly impact the data scatter. A film controlled to the minimum range is preferred over the uncontrolled standard heavy phosphate originally called out.

7.2.2 *Cleaners*—Select a cleaning media and method which is safe, non-film forming and which does not in any way attack or etch the surface chemically. In addition, no Class 1 ozone depleting substances conforming to Section 602(a) of the Clean Air Act Amendments of 1990 (42USC7671a) as identified in Section 326 of PL 102-484 should be used. Use a procedure as outlined in Test Method **F22** to judge the merit of the selected cleaning technique.

NOTE 4—A typical solvent found acceptable for this purpose is Stoddard solvent.

7.2.2.1 No method of cleaning can be judged as acceptable unless there is a valid method of judging the success or failure of the cleaning method. Test Method **F22** is a simple procedure that can be used on the actual test apparatus or on test coupons to judge each cleaning method's viability.

7.2.3 *Aluminum Oxide*, ~~white~~ **white** angular abrasive, ~~180 grit to 220 grit~~, **180 grit to 220 grit**.

8. Preparation of Apparatus

8.1 Thoroughly clean the jaw supports for the vee blocks and test journals, by washing with the solvent selected from **7.2.2**, of all debris or oil from previous test runs. See **Note 4**.

8.2 Avoid contact with the fingers of the mating surfaces of the vee blocks and test pins.

8.3 Avoid atmospheric contamination such as cigarette smoke, as this can adversely affect the test results.

9. Calibration of Load Gauge

9.1 *Calibration Procedure with* ~~4500 lbf (20 000 N)~~ **4500 lbf (20 000 N)** *Load Gauge*:

9.1.1 Remove the Allen set screw and 12.70 mm (1/2 in.) ball from the left jaw socket (**Fig. 4**).

9.1.2 Insert the special Allen screw with the attached 10 mm Brinell ball into the working face of the left jaw. Adjust so that the ball projects about 4 mm (3/32 in.) from face of the jaw.

9.1.3 Insert the back-up plug in the counterbore of the right-hand jaw. Adjust so that the plug projects about 0.8 mm (1/32 in.) from the face.

9.1.4 Support the standard test coupon so that the upper edge of the coupon is about 2.5 mm (3/32 in.) below the upper surface of the jaws. Place a steel rule across the face of the jaws. Adjust the Allen screw with the attached 10 mm ball until the face of the jaws are parallel to the steel rule with the test coupon in position for indentation.

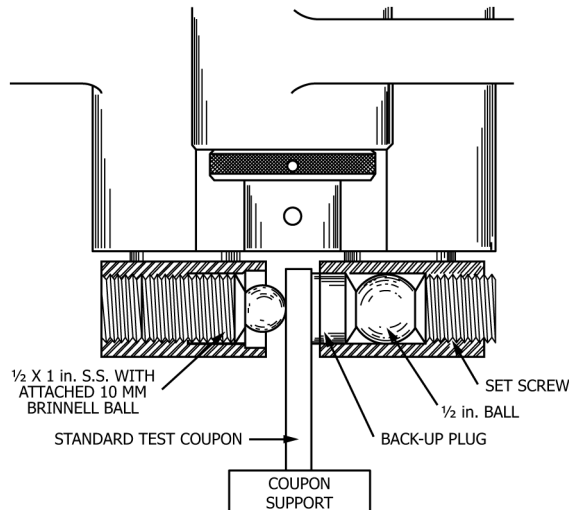

FIG. 4 Schematic Drawing of Calibration Accessories for Falex Pin and Vee Block Test Machine

9.1.5 With the test coupon in position for the first impression, place the load gauge assembly on the lever arms.

9.1.6 Place the loading arm on the ratchet wheel and actuate the motor. Allow the motor to run until the load gauge indicates a load of 300 lbf (1330 N). A slight takeup on the ratchet wheel is required to hold the load due to the ball sinking into the test coupon. After the 300 lbf (1330 N) load is obtained, hold for 1 min for the indentation to form.

9.1.7 Turn off the machine and back off the load until the test coupon is free of the jaws. Advance the test coupon approximately 9.5 mm ($\frac{3}{8}$ in.) (additional indentations should be separated by a minimum distance of $2.5 \times$ the diameter of the initial indentation). Check the alignment of the jaws, and repeat the procedure described in 9.1.6 at gauge loads of 750 lbf, 1000 lbf, and 1500 lbf (3300 N, 4450 N, and 6650 N).

9.1.8 Remove the load gauge assembly and test coupon and measure the diameter of each indentation to 0.01 mm with the Brinell microscope. Make three measurements of the indentation diameter, rotating the test coupon to ensure that no two measurements represent the same points. Average the three measurements of each impression and record.

9.1.9 Plot the four impression readings versus gauge load readings on log-log paper (K&E 467080 or equivalent). If they do not plot as an approximately straight line, repeat steps 9.1.4 – 9.1.8. A standard curve of impression diameter versus gauge reading is shown in Fig. 3. If the indentation diameter, plotted as above, is lower or higher than that shown on the standard curve, determine the actual load necessary to produce the indentation diameter that will correspond to that shown on the standard curve.

NOTE 5—A full-size standard calibration curve, plotted on log-log paper and similar to Fig. 3 but with finer subdivision lines included, should be used for accurate calibration.

9.2 Calibration Procedure with 800 lbf or 3000 lbf (3550 N or 13 300 N) Direct-Reading Load Gauge:

9.2.1 Use the same procedure as with the 4500 lbf (20 000 N) gauge above, except obtain impressions at gauge readings of 300 lbf, 500 lbf, 700 lbf, and 800 lbf (1330 N, 2220 N, 3100 N, and 3550 N) on the 800 lbf (3550 N) gauge; or at 300 lbf, 700 lbf, 1100 lbf, and 1700 lbf (1330 N, 3100 N, 4880 N, and 7550 N) on the 3000 lbf (13 300 N) gauge. Plot the impression readings versus gauge load readings, as in 9.1.9, with similar adjustments to the load in order to produce indentation diameter that corresponds to the indentation diameter on the standard curve.

10. Procedure A

10.1 Insert the solid film coated vee blocks in the recesses of the load jaws.

10.2 Mount the solid film coated pin in the test shaft and insert a new brass shear pin as shown in Fig. 1 and Fig. 2.

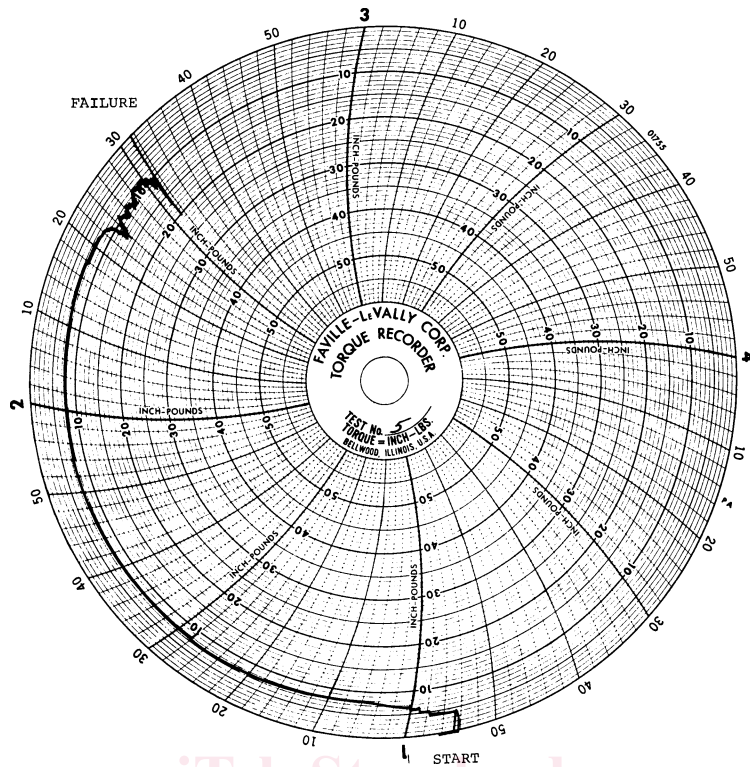

FIG. 5 Trace of Typical Torque Pattern for Procedure A, Using Falex Torque Recorder and Automatic Cutoff

10.3 Swing the arms inward so that the vee blocks contact the test pin in such a way that the vee grooves are aligned with the pin's major axis as shown in Fig. 2. Check this alignment visually. Place the automatic loading mechanism with attached load gauge on the load arms and turn the ratched wheel by hand until the test parts are securely seated, indicated by a slight upward movement of the load gauge needle. At this point the torque gauge should read zero or be adjusted to read zero.

10.4 Start the motor and engage the automatic loading ratchet until a gauge load of 300 lbf (1330 N) is reached (approximately 265 lbf (1170 N) on the direct-reading gauge). Remove the load applying arm and continue running (at 290 r/min \pm 10 r/min) for 3 min, then increase the load to 500 lbf (2220 N) (approximately 410 lbf (1820 N) on the direct-reading gauge) using the load applying arm, and run for 1 min.

10.5 Increase load to 750 lbf (3330 N) (590 lbf (2620 N) on the direct-reading gauge) and run for 1 min. Then increase the load to 1000 lbf (4450 N) (765 lbf (3400 N) on the direct-reading gauge). Maintain this load and measure the time until failure. Load should be maintained by taking up on the ratchet wheel as necessary. The total time until failure shall not include the 3-min run-in.

10.6 Failure is indicated by a torque rise of 10 in.·lbf (1.13 N·m) above the steady-state value, or breakage of the shear pin. The test shall be continued until one of the above failure criteria is attained. If the optional automatic cutoff, torque recorder, and timer (6.1.2) is used, set the cutoff point to 10 in.·lbf (1.13 N·m) above the initial steady state torque. When this preset torque is reached, the machine will shut off and the time of test may be read from the torque recorder tracer⁶ (Fig. 5).

10.7 Four runs shall constitute a test.

11. Procedure B

11.1 Repeat the cleaning and set-up procedures outlined in Section 8 and 10.1 – 10.3.

11.2 Start the motor and engage the automatic loading ratchet until a gauge load of 300 lbf (1330 N) (approximately 265 lbf (1170 N) on the direct-reading gauge) is reached. Remove the load applying arm and continue running (at 290 r/min \pm 10 r/min) for 3 min. Then increase the load to 500 lbf (2220 N) (approximately 410 lbf (1820 N) on the direct-reading gauge) using the load applying arm and run for 1 min.