



Designation: ~~C1422/C1422M—20~~ C1422/C1422M – 20a

Standard Specification for Chemically Strengthened Flat Glass¹

This standard is issued under the fixed designation C1422/C1422M; the number immediately following the designation indicates the year of original adoption or, in the case of revision, the year of last revision. A number in parentheses indicates the year of last reapproval. A superscript epsilon (ϵ) indicates an editorial change since the last revision or reapproval.

1. Scope

1.1 This specification covers the requirements for chemically strengthened glass products that are used in general building construction, transportation, solar, and other electronic applications, such as PC screens, notebooks, tablets, smart phones, and E-readers, as well as copy machine scanners, computer disks, and flat glass screens for television monitors. The technique covered in this specification usually involves conducting ion exchange of constituent alkali ions in a glass product by immersing it in a bath of molten salt containing larger alkali ions. Penetration of the larger ions into smaller host sites produces a layer of compression on the surface which strengthens the glass. Techniques such as ion implantation, dealcalization, etch-strengthening, and glaze coatings are specifically excluded from this specification.

1.2 Classification of chemically strengthened glass products is based on the laboratory measurements of surface compression and case depth (depth of compression) and not on the modulus of rupture (MOR). This specification does not purport to address end-use performance.

1.3 A test method for the measurement of case depth and surface compression is included in Section 8. Another test method for similar measurement using optically guided-wave equipment is included in Section 9.

1.4 The values stated in either SI units or inch-pound units are to be regarded separately as standard. The values stated in each system ~~may~~ are not necessarily exact equivalents; therefore, to ensure conformance with the standard, each system shall be used independently of the other. ~~Combining other, and values from the two systems may result in non-conformance with the standard; shall not be combined.~~

1.5 *This standard does not purport to address all of the safety concerns, if any, associated with its use. It is the responsibility of the user of this standard to establish appropriate safety, health, and environmental practices and determine the applicability of regulatory limitations prior to use.*

1.6 *This international standard was developed in accordance with internationally recognized principles on standardization established in the Decision on Principles for the Development of International Standards, Guides and Recommendations issued by the World Trade Organization Technical Barriers to Trade (TBT) Committee.*

2. Referenced Documents

2.1 ASTM Standards:²

C162 Terminology of Glass and Glass Products

C770 Test Method for Measurement of Glass Stress—Optical Coefficient

¹ This specification is under the jurisdiction of ASTM Committee C14 on Glass and Glass Products and is the direct responsibility of Subcommittee C14.08 on Flat Glass. Current edition approved April 15, 2020/Aug. 1, 2020. Published April 2020/September 2020. Originally approved in 1999. Last previous edition approved in 2015/2020 as C1422/C1422M—15. C1422/C1422M – 20. DOI: 10.1520/C1422-C1422M-20.10.1520/C1422_C1422M-20A.

² For referenced ASTM standards, visit the ASTM website, www.astm.org, or contact ASTM Customer Service at service@astm.org. For *Annual Book of ASTM Standards* volume information, refer to the standard's Document Summary page on the ASTM website.

C978 Test Method for Photoelastic Determination of Residual Stress in a Transparent Glass Matrix Using a Polarizing Microscope and Optical Retardation Compensation Procedures

C1036 Specification for Flat Glass

C1279 Test Method for Non-Destructive Photoelastic Measurement of Edge and Surface Stresses in Annealed, Heat-Strengthened, and Fully Tempered Flat Glass

C1648 Guide for Choosing a Method for Determining the Index of Refraction and Dispersion of Glass

E1967 Test Method for the Automated Determination of Refractive Index of Glass Samples Using the Oil Immersion Method and a Phase Contrast Microscope

F218 Test Method for Measuring Optical Retardation and Analyzing Stress in Glass

2.2 *ANSI Standard:*³

~~Z97.1-2015~~ Z97.1-2015-Safety Glazing Materials Used In Buildings - Safety Performance Specifications And Methods Of Test

2.3 ~~Federal Document:Standard:~~⁴

~~EPSC-16CFR~~ 16 CFR 1201 Consumer Product Safety Commission Safety Standard for Architectural Glazing Materials

iTeh Standards (<https://standards.iteh.ai>) Document Preview

[ASTM C1422/C1422M-20a](#)

<https://standards.iteh.ai/catalog/standards/sist/d35293c6-53d9-42fb-a797-a626dda2f332/astm-c1422-c1422m-20a>

³ Available from American National Standards Institute (ANSI), 25 W. 43rd St., 4th Floor, New York, NY 10036, <http://www.ansi.org>.

⁴ Available from U.S. Consumer Product Safety Commission (CPSC), 4330 East West Hwy., Bethesda, MD 20814, <http://www.cpsc.gov>.

3. Terminology

3.1 Definitions:

3.1.1 ~~Refer~~ For definitions of general terms used in this specification, refer to Terminology C162, as appropriate. For definitions of terms concerning flat glass blemishes, refer to Specification C1036.

3.1.2 ~~blemishes, n—refer to Specification C1036 for flat glass.~~

3.2 Definitions of Terms Specific to This Standard:

3.2.1 *case depth, n*—depth of compression below the surface to the nearest zero stress ~~plane. This plane;~~ this measurement does not depend upon the wavelength of the light beam employed.

3.2.2 *center tension (CT), n*—the magnitude of the maximum in-plane tensile stress in the interior of the glass away from the ion-exchanged region.

3.2.3 *chemically strengthened glass, n*—glass which has been strengthened by ion exchange to produce a compressive stress layer at the treated surface.

3.2.4 *depth of compression (DOC), n*—see *case depth*.

3.2.5 *depth of layer (DOL), n*—in optically guided-wave type equipment, the DOL is the depth of location where the differential refractive index profile reverses sign; this depth is shorter than the depth of ion penetration when measured using instruments such as the spectroscopic microprobe, and is longer than the case depth.

3.2.6 *ion exchange process (IOX or IX), n*—the exchange of constituent ions in the glass with externally supplied ions (generally at temperatures near the strain point of the glass), which when of a larger ionic radius, build strengthening compressive stress in the exchange region; this may be accomplished by immersing glass in a molten salt bath or solution with or without electric field, ultrasonic or other assistance, exposing glass to plasma, applying a paste on the glass surface, or contacting glass with molten salts in a furnace; in some cases, ion exchange can be conducted sequentially using multiple baths.

3.2.7 *surface compression or compressive stress (CS), n*—an in-plane (biaxial) stress which causes the length generated by constraining the expansion of the surface along both planar axes to be reduced with respect to its equilibrium value.” relative to its equilibrium length along both planar axes.

4. Significance and Use

4.1 Chemically strengthened glass is significantly stronger than annealed glass, depending upon the glass composition, strengthening process, level of abrasion, and the application environment. The strengthening process does not contribute significantly to optical distortion.

4.2 The chemical strengthening process can effectively strengthen glass of all sizes and shapes and can be useful in cases in which glass is too thin, small, or complex-shaped for thermal tempering.

4.3 Monolithic chemically strengthened glass is not a safety glazing product because its break pattern is similar to that of annealed glass. When safety glazing is required, chemically strengthened glass shall pass the requirements of ANSI Z97.1-2015, or shall be laminated in accordance with CPSC 16CFR 1201 Cat. I or Cat. II or ANSI Z97.1-2015.

4.4 The very nature of the chemical strengthening process alters the glass surface chemistry. Therefore, the procedures for and the performance of postprocessing steps, such as laminating and coating, can be different from that of nonchemically strengthened glass.

4.5 Modulus of rupture (MOR), weight gain measurement, and optical methods are examples of procedures used for process control in chemical strengthening. In addition to those described in Sections 8 and 9, optical methods utilizing differential surface

refractometer (DSR) and scattered light photoelasticity stress meter (SLP) have been proven to be reliable for some specific glass types and thicknesses and some specific ion-exchange couples (potassium for sodium in the glass or sodium for lithium in the glass).

5. Classification

5.1 *Kinds*—Chemically strengthened glass furnished in accordance with this specification shall be classified on the basis of the surface compression levels (Level 1-7) and case depth (Levels A-F). Surface compression and case depth are independent of each other. Increasing levels of surface compression permit an increasing amount of flexure. Greater case depths offer more protection from strength reduction caused by abuse and abrasion. Case depth values may vary on different thicknesses of the same glass type which have been manufactured under similar chemical exchange conditions. For classification purposes, all surface compression and case depth values are to be reported, along with the sheet thickness of the witness specimen in accordance with 8.1.3. See Fig. 1 and Fig. 1a.

5.1.1 Surface Compression:

5.1.1.1 *Level 1*—Surface compression, >7 MPa [1000 psi] ≤ 172 MPa [$25\,000$ psi].

5.1.1.2 *Level 2*—Surface compression, >172 MPa [$25\,000$ psi] ≤ 345 MPa [$50\,000$ psi].

5.1.1.3 *Level 3*—Surface compression, >345 MPa [$50\,000$ psi] ≤ 517 MPa [$75\,000$ psi].

5.1.1.4 *Level 4*—Surface compression, >517 MPa [$75\,000$ psi] ≤ 690 MPa [$100\,000$ psi].

5.1.1.5 *Level 5*—Surface compression, >690 MPa [$100\,000$ psi] ≤ 862 MPa [$125\,000$ psi].

5.1.1.6 *Level 6*—Surface compression, >862 MPa [$125\,000$ psi] ≤ 1034 MPa [$150\,000$ psi].

5.1.1.7 *Level 7*—Surface compression, >1034 MPa [$150\,000$ psi].

5.1.2 Case Depth:

5.1.2.1 *Level A1*—Case depth, ≤ 25 μm [0.001 in.].

5.1.2.2 *Level A2*—Case depth, >25 μm and ≤ 50 μm [0.002 in.].

5.1.2.3 *Level B*—Case depth, >50 μm [0.002 in.] and ≤ 150 μm [0.006 in.].

5.1.2.4 *Level C*—Case depth, >150 μm [0.006 in.] and ≤ 250 μm [0.010 in.].

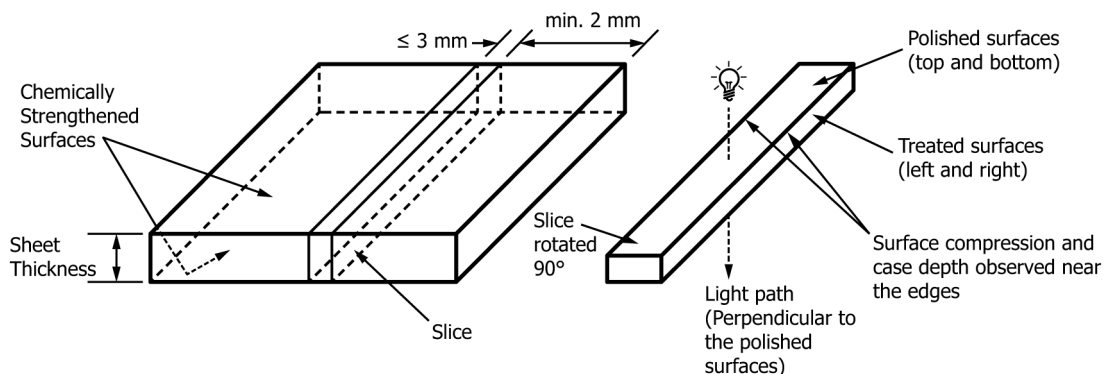

Fig. 1 Slice Location

Fig. 1a Finished Slice

FIG. 1 Slice Location

5.1.2.5 *Level D*—Case depth, $>250\ \mu\text{m}$ [0.010 in.] and $\leq 350\ \mu\text{m}$ [0.014 in.].

5.1.2.6 *Level E*—Case depth, $>350\ \mu\text{m}$ [0.014 in.] and $\leq 500\ \mu\text{m}$ [0.020 in.].

5.1.2.7 *Level F*—Case depth, $>500\ \mu\text{m}$ [0.020 in.].

6. Ordering Information

6.1 Purchasers should select the preferred options permitted in this specification and include the following information in the procurement documents:

- 6.1.1 Title, number, and date of this ~~specification~~ specification,
- 6.1.2 Glass ~~thickness~~ thickness,
- 6.1.3 Surface compression (see 5.1.1) or minimum acceptable ~~value~~ value,
- 6.1.4 Case depth (see 5.1.2) or minimum acceptable ~~value~~ value, and
- 6.1.5 Fabrication information (see 7.1).

7. Fabrication

7.1 *Fabrication*—After the glass has been chemically strengthened, it shall only be modified as recommended by the fabricator. No modification shall be made that will affect the surface compression and case depth. Glass which has been cut after chemical strengthening without subsequent strengthening of the cut edge plane by ion-exchange may be characterized as having a uniaxial stress (or birefringence) profile across such an edge which comprises at least one of an absence of compressive stress, exposed edge plane essentially that of a thin slice shown in Fig. 2, an otherwise reduced compressive stress, and exposed tensile stress. The exposed tensile stress in the mid-region may increase the risk of glass fracture. The fabricator shall disclose to the end user instances where glass has been cut after chemical strengthening without subsequent strengthening of the cut edge by ion exchange and any permanent logo applied to such a glass article shall include the words “CUT AFTER STRENGTHENING.”

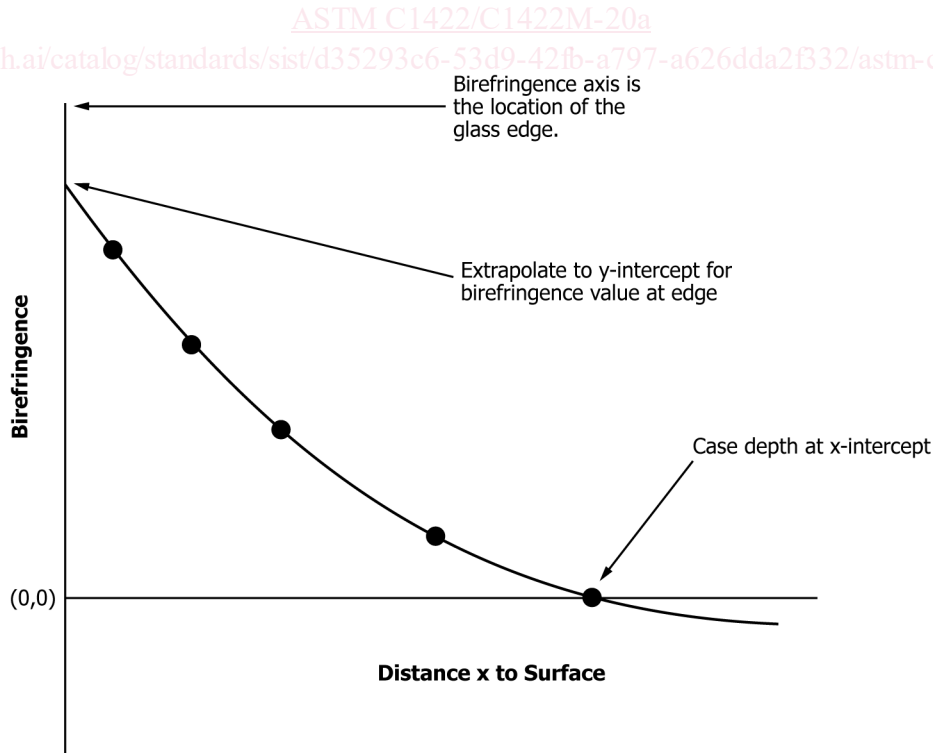

7.1.1 *Thickness*—Substrates for chemically strengthened glass shall be in accordance with the thicknesses in Specification **C1036** or as specified therein (see Section 6). All thicknesses may not be available. Consult the manufacturer or the fabricator.

8. Test Method

8.1 Preparation of Test Specimen:

8.1.1 Prepare the test specimens from the same material as the test batch and anneal before chemically strengthening.

8.1.2 Protect the edges of the test specimens during the preparation process (slicing, grinding, smoothing).

8.1.3 A witness specimen plate having length and width at a minimum of six times the sheet thickness shall be processed. Both the large flat faces of the specimen shall have the as-fabricated condition. After the chemical strengthening process, slice a section from this specimen perpendicularly at least 2 mm [0.08 in.] away from the ends (see **Fig. 1**). The slice thickness shall not exceed 3 mm, which allows for grinding and polishing loss. Lightly polish the slice on its non-chemically strengthened surfaces using conventional ceramographic techniques and examine it for classification by viewing the optical retardation through the slice thickness.

NOTE 1—The recommended range is from 0.15 to 3.00 mm [0.005 to 0.12 in.]. Specimen thicknesses at the lower end of this range yield better results.

8.2 Apparatus for Measuring of Surface Stress and Case Depth in Section (Slice) Using Polarizing Microscope:

8.2.1 *Microscope*, used with a minimum objective times eyepiece magnification of 25×. Case depths ~~<50 microns~~ <50 μm shall use a minimum magnification of 50×. The optimum magnification shall be selected based on the case depth.

8.2.2 *Polarizers*, installed in mutually crossed orientation, aligned at +45° to the symmetry plane of the microscope.

8.2.3 *Means of Measuring Distances Between Black Fringe and Edge*, including a fine-graduated reticle, an eyepiece reticle, or stage micrometer of appropriate resolution. The measuring system must resolve 1 μm or 2 % of the case depth, whichever is greater.

8.3 Measurement of Case Depth:

8.3.1 Using white light, identify the black fringe representing the transition from mid-plane tension to surface compression. Make the measurement of case depth from the center of that black fringe to the nearest fabrication surface using the reticle or micrometer. Compute the separation between the center of the dark fringe and the nearest surface using the known calibration and report as the case depth (see **Fig. 23(a)** and **Fig. 23(b)**).

8.4 Measurement of Surface Stress:

8.4.1 The retardation at the edge of the slice removed from the witness specimen, in other words, the surface stress of the sheet, can be measured and converted into stress units by using a microscope defined in 8.2, either in conjunction with a suitable compensator in accordance with Test Method **C978** or by photoelastic color pattern observation (in accordance with Test Method **F218**). The retardation can be converted to stress using the stress optic coefficient obtained from Test Method **C770** or **Eq 1**.

8.4.2 When visibility of the edge is inadequate, extrapolation techniques are permitted. To implement the extrapolation, measure the optical retardation or birefringence at several points between the zero fringe and the edge, typically in 10 μm intervals (a minimum of three points is required). The profile must be then extrapolated to the edge as shown in **Fig. 32**.

8.4.3 Alternate methods (not applicable to 8.1 or 8.2) include:

8.4.3.1 Differential surface refractometry (DSR) for some glass compositions, in accordance with Test Method **C1279**, Procedure **A-A**, and

8.4.3.2 Scattered light photoelasticity (suitable for some glass types).

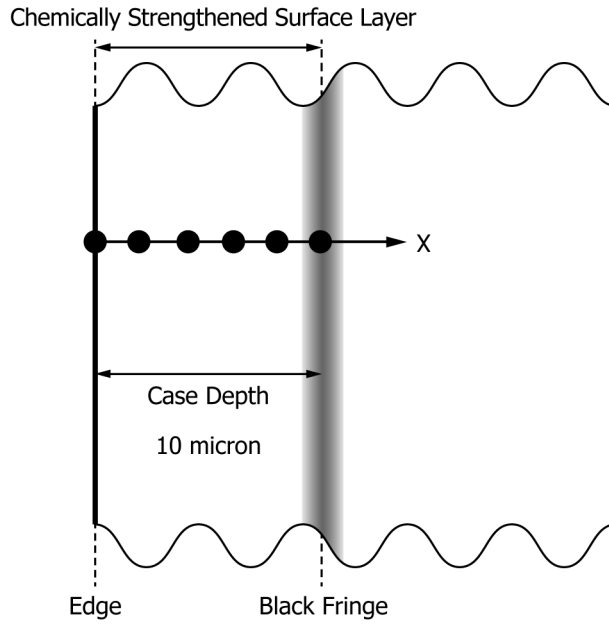

FIG. 23 (a) Case Depth and Birefringence Measurement Positions

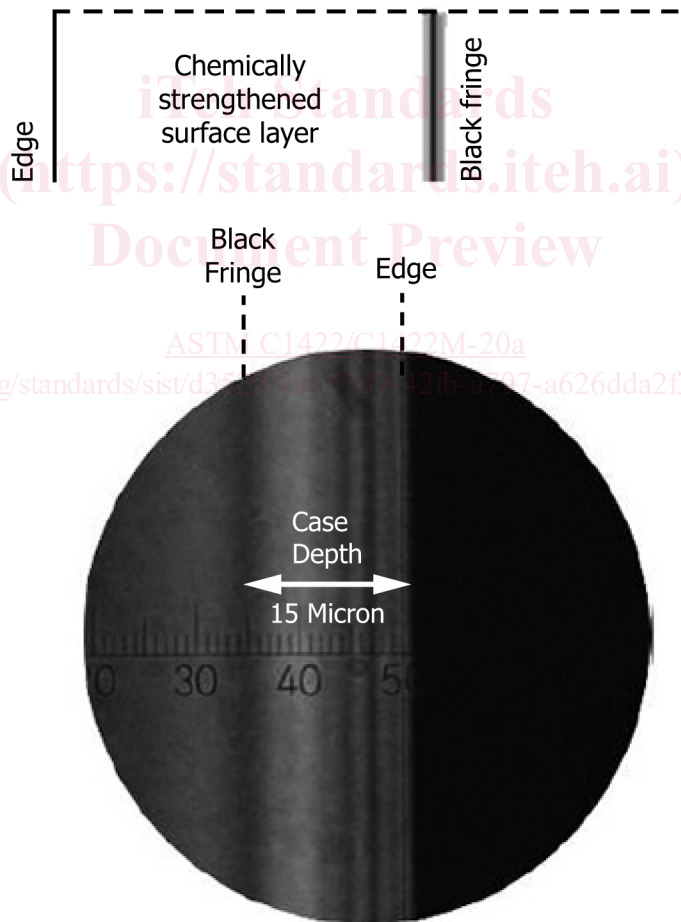

FIG. 23 (b) Photo from Polarizing Microscope Using Monochromatic Filter and Eyepiece Reticle to Measure Case Depth