



Designation: D2303 – 20

Standard Test Methods for Liquid-Contaminant, Inclined-Plane Tracking and Erosion of Insulating Materials¹

This standard is issued under the fixed designation D2303; the number immediately following the designation indicates the year of original adoption or, in the case of revision, the year of last revision. A number in parentheses indicates the year of last reapproval. A superscript epsilon (ϵ) indicates an editorial change since the last revision or reapproval.

This standard has been approved for use by agencies of the U.S. Department of Defense.

1. Scope*

1.1 These test methods cover the evaluation of the relative tracking and erosion resistance of insulating solids using the liquid-contaminant, inclined-plane test.² The following test methods also can be used to evaluate the tracking resistance of materials: Test Method **D2132** (contaminants: dust and fog) and Test Method **D3638** (contaminant: conductive liquid drops).

1.2 Two tracking and one erosion test procedure are described:

1.2.1 A “variable voltage method” to evaluate resistance to tracking.

1.2.2 A “time-to-track method” to evaluate resistance to tracking.

1.2.3 A method for quantitative determination of erosion (**Annex A1**).

1.3 While a particular contaminant solution is specified, other concentrations of the same contaminant, or different contaminants are used to simulate different environmental or service conditions.

1.4 The values stated in inch-pound units are to be regarded as standard. The values given in parentheses are mathematical conversions to SI units that are provided for information only and are not considered standard.

1.5 Although this standard and IEC 60587-2007, “Test Methods for Evaluating Resistance to Tracking and Erosion for Electrical Insulating Materials Used Under Severe Ambient Conditions,” differ in approach or detail, data obtained using either are technically equivalent.

1.6 *This standard does not purport to address all of the safety concerns, if any, associated with its use. It is the*

¹ These test methods are under the jurisdiction of ASTM Committee **D09** on Electrical and Electronic Insulating Materials and are the direct responsibility of Subcommittee **D09.12** on Electrical Tests.

Current edition approved Aug. 1, 2020. Published September 2020. Originally approved in 1964. Last previous edition approved in 2013 as D2303 – 13. DOI: 10.1520/D2303-20.

² K. N. Mathes, “Surface Failure Measurements,” Chapter 4 of *Engineering Dielectrics Volume IIB Electrical Properties of Solid Insulating Materials: Measurement Techniques*, ASTM STP 926, ASTM International, 1987.

responsibility of the user of this standard to establish appropriate safety, health, and environmental practices and determine the applicability of regulatory limitations prior to use. Specific precautionary statements are given in Section 9.

1.7 *This international standard was developed in accordance with internationally recognized principles on standardization established in the Decision on Principles for the Development of International Standards, Guides and Recommendations issued by the World Trade Organization Technical Barriers to Trade (TBT) Committee.*

2. Referenced Documents

2.1 *ASTM Standards:*³

D374/D374M Test Methods for Thickness of Solid Electrical Insulation

D1711 Terminology Relating to Electrical Insulation

D2132 Test Method for Dust-and-Fog Tracking and Erosion Resistance of Electrical Insulating Materials

D3638 Test Method for Comparative Tracking Index of Electrical Insulating Materials

2.2 *IEC Standard:*

IEC 60587-2007 Test Methods for Evaluating Resistance to Tracking and Erosion for Electrical Insulating Materials Used Under Severe Ambient Conditions

3. Terminology

3.1 *Definitions:*

3.1.1 *erosion, electrical, n*—the progressive wearing away of electrical insulation by the action of electrical discharges.

3.1.2 *erosion resistance, electrical, n*—the quantitative expression of the amount of electrical erosion under specific conditions.

3.1.3 *track, n*—a partially conducting path of localized deterioration on the surface of an insulating material.

³ For referenced ASTM standards, visit the ASTM website, www.astm.org, or contact ASTM Customer Service at service@astm.org. For *Annual Book of ASTM Standards* volume information, refer to the standard’s Document Summary page on the ASTM website.

*A Summary of Changes section appears at the end of this standard

3.1.4 *tracking, n*—the process that produces tracks as a result of the action of electric discharges on or close to the insulation surface.

3.1.5 *tracking, contamination, n*—tracking caused by scintillations that result from the increased surface conduction due to contamination.

3.1.6 *tracking resistance, n*—the quantitative expression of the voltage and the time required to develop a track under specified conditions.

3.2 Definitions of Terms Specific to This Standard:

3.2.1 *initial tracking voltage, n*—the applied voltage at which continuous tracking can be initiated in a specified time.

3.2.2 *time-to-track, n*—the time in which tracking proceeds a specified distance between the test electrodes at a specified voltage.

3.3 Other definitions pertinent to these test methods are given in Terminology [D1711](#).

4. Hazards

4.1 High Voltage:

4.1.1 Lethal voltages are a potential hazard during the performance of this test. It is essential that the test apparatus, and all associated equipment electrically connected to it, be properly designed and installed for safe operation.

4.1.2 Solidly ground all electrically conductive parts which it is possible for a person to contact during the test.

4.1.3 Provide means for use at the completion of any test to ground any parts which were at high voltage during the test or have the potential for acquiring an induced charge during the test or retaining a charge even after disconnection of the voltage source.

4.1.4 Thoroughly instruct all operators as to the correct procedures for performing tests safely.

4.1.5 When making high voltage tests, particularly in compressed gas or in oil, it is possible for the energy released at breakdown to be sufficient to result in fire, explosion, or rupture of the test chamber. Design test equipment, test chambers, and test specimens so as to minimize the possibility of such occurrences and to eliminate the possibility of personal injury. If the potential for fire exists, have fire suppression equipment available.

5. Significance and Use

5.1 These test methods differentiate solid electrical insulating materials on the basis of their resistance to the action of voltage stresses along the surface of the solid when wet with an ionizable, electrically conductive liquid contaminant.

5.2 These test methods quantitatively evaluate, in a relative manner, the effects upon an insulating material resulting from the action of electrical discharges upon a material surface. The effects are similar to those that may occur in service under the influence of dirt combined with moisture condensed from the atmosphere.

5.2.1 In the field, the conditions resulting in electrical discharges occur sporadically. Degradation, often in the form of a conducting “track,” develops very slowly until it ulti-

mately bridges the space between conductors thus causing complete electrical breakdown.

5.2.2 In these test methods, the conducting liquid contaminant is continuously supplied at an optimum rate to the surface of a test specimen in such a fashion that essentially continuous electrical discharge can be maintained.

5.2.3 By producing continuous surface discharge with controlled energy it is possible, within a few hours, to cause specimen failure which is similar to failure occurring under long-time exposure to the erratic conditions of service in the field.

5.2.4 The test conditions, which are standardized and accelerated, do not reproduce all of the conditions encountered in service. Use caution when making either direct or comparative service behavior inferences derived from the results of tracking tests.

5.3 The time-to-track a 1-in. (25 mm) distance at a specified voltage between electrodes separated 2 in. (50 mm) has also been found useful in categorizing insulating materials for indoor and protected outdoor applications, such as metal-clad switchgear.

5.4 The initial tracking voltage has been found useful for evaluating insulating materials to be used at high voltages or outdoors and unprotected, as well as for establishing (see [11.1](#)) the test voltage for the time-to-track test.

5.5 In service many types of contamination cause tracking and erosion of different materials to different degrees. This test method recognizes the importance of such variability and suggests the use of special test solutions to meet specific service needs. For example, an ionic contaminant containing, in addition, a carbonaceous component such as sugar is substituted to cause tracking on very resistant materials like polymethylmethacrylate. Such contamination is considered representative of some severe industrial environments. In this case, the time-to-track technique is used, since time is required to decompose the contaminant solution and build up conducting residues on the sample surface.

5.6 Very track-resistant materials, such as polymethylmethacrylate, typically erodes rather than track under more usual contaminant conditions in service. The use of this method for measuring erosion is consequently important. For erosion studies, only tests as a function of time at constant voltage are useful.

6. Apparatus

6.1 A simple schematic diagram of the apparatus is given in [Fig. 1](#) and consists of the following. Details are given in [Annex A2](#).

6.1.1 A 60 Hz power supply with an output voltage stabilized to $\pm 1\%$ which can be varied from 1 to at least 7.5 kV with a rated current of no less than 0.1 A for every test station to be used (that is, 0.5 A for five stations).

6.1.2 A means for applying a specified contaminant solution at a controlled rate to the specimen surface. A pneumatically actuated repeating pipet has been found useful for this purpose and is described in [Annex A2](#). Peristaltic pumps have also been used (see [Annex A2](#)).

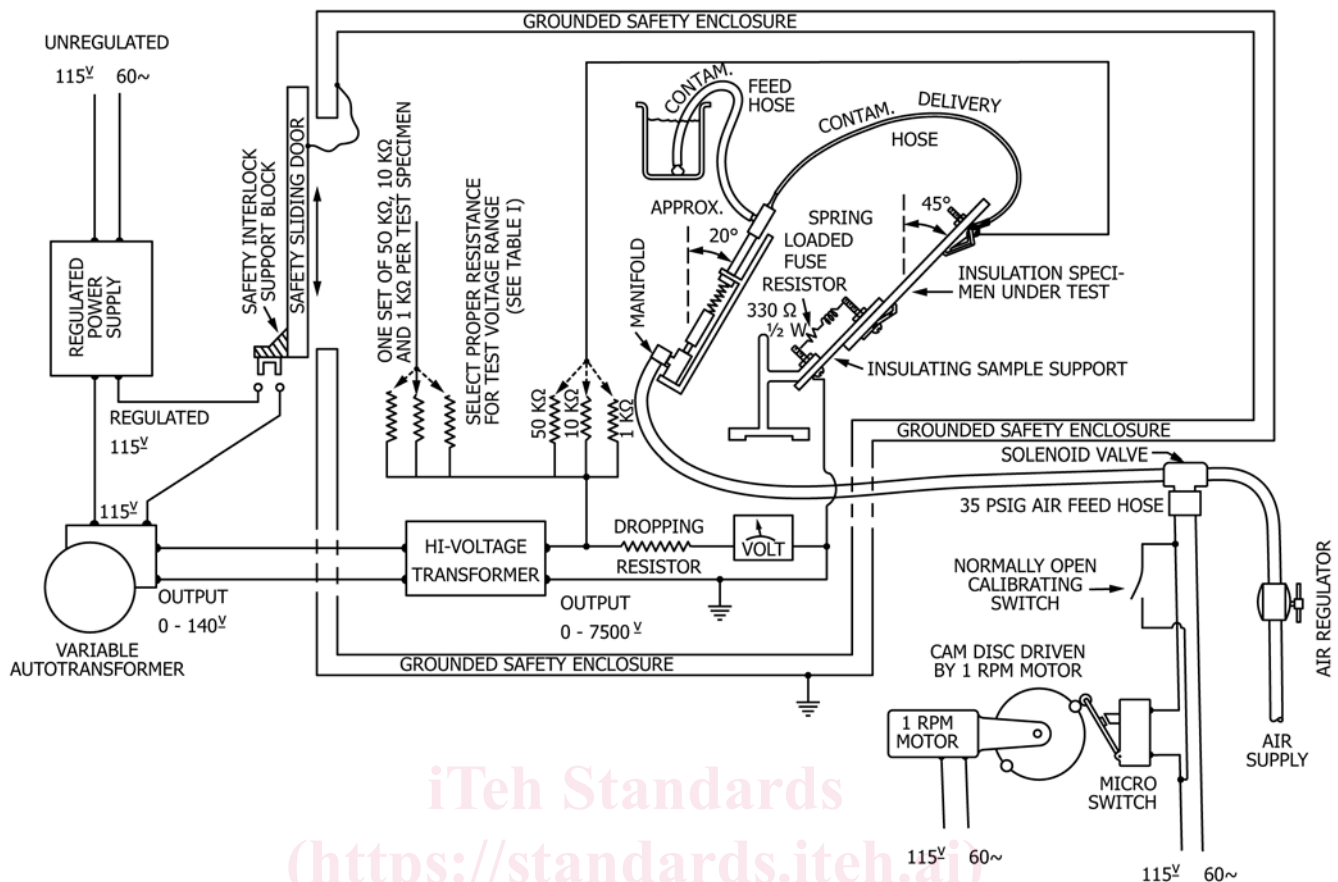

FIG. 1 Schematic Diagram of Apparatus

6.1.3 Stainless steel top and bottom electrodes as shown in Fig. 2.

NOTE 1—Stainless steel type 302 is recommended.

6.1.4 A pad of filter paper cut as shown in Fig. 3(a) and Fig. 3(b) to fit under the top electrode and used to smooth out the flow of the contaminant solution.

6.1.5 A set of ballast resistors (50, 10, and 1 kΩ rated at 200 W each) to be connected as specified in series with each test specimen on the high-voltage side of the power supply. Somewhat lower resistances are being considered by the International Electrotechnical Commission (IEC/TC15).

6.1.6 A 330 Ω, ½ W, carbon resistor mounted with a simple tension spring and connected in series with the specimen and ground to act as an overload, high-voltage fuse.

NOTE 2—RC20 mil type carbon composition resistors are commercially available from several sources.

6.1.7 Structural parts and a grounded safety enclosure.

6.1.8 Clip to hold the hose and filter paper in place. Fig. 3(a) and Fig. 3(b) shows an example of a paper clip configuration that may be used. Other paper clip configurations may be used as long as they do not pinch the hose affecting the contaminant flow.

7. Sampling

7.1 Refer to applicable materials specifications for sampling instructions.

8. Test Specimens

8.1 Specimens with a flat surface measuring approximately 2 × 5 in. (50 × 125 mm) as shown in Fig. 4. Measure the thickness in accordance with Test Methods D374/D374M if there is no standard for a particular material. Specimens must be thick enough that tracking does not penetrate completely through the specimen during the test.

8.1.1 Thin specimens shall be mounted on the apparatus as individual layers (that is, samples shall not be stacked).

8.1.2 Thin specimens shall be secured by mounting them on a support plaque made from an inert nonconductive material. Fig. 3(a) shows an example of a mounting support plaque made out of PTFE (polytetrafluoroethylene) at an approximate thickness of 6 mm.

8.1.3 Care shall be exercised with thin specimens to ensure contaminant does not flow on the back of the specimen. This can lead to inconclusive results.

8.2 Prepare separate specimens representative of different surfaces affected by anisotropy, morphology, texture, surface treatments, pull direction, fill direction, etc. Identify the different surfaces to be tested, such as mold face, press face, textured side, machine direction, cross-machine direction, warp or fill direction, etc. Prepare two sets of specimens of materials with noticeable directional characteristics, with the predominant directional characteristic in line with the electrodes for one set and at right angles to the other set. Identify the specimen

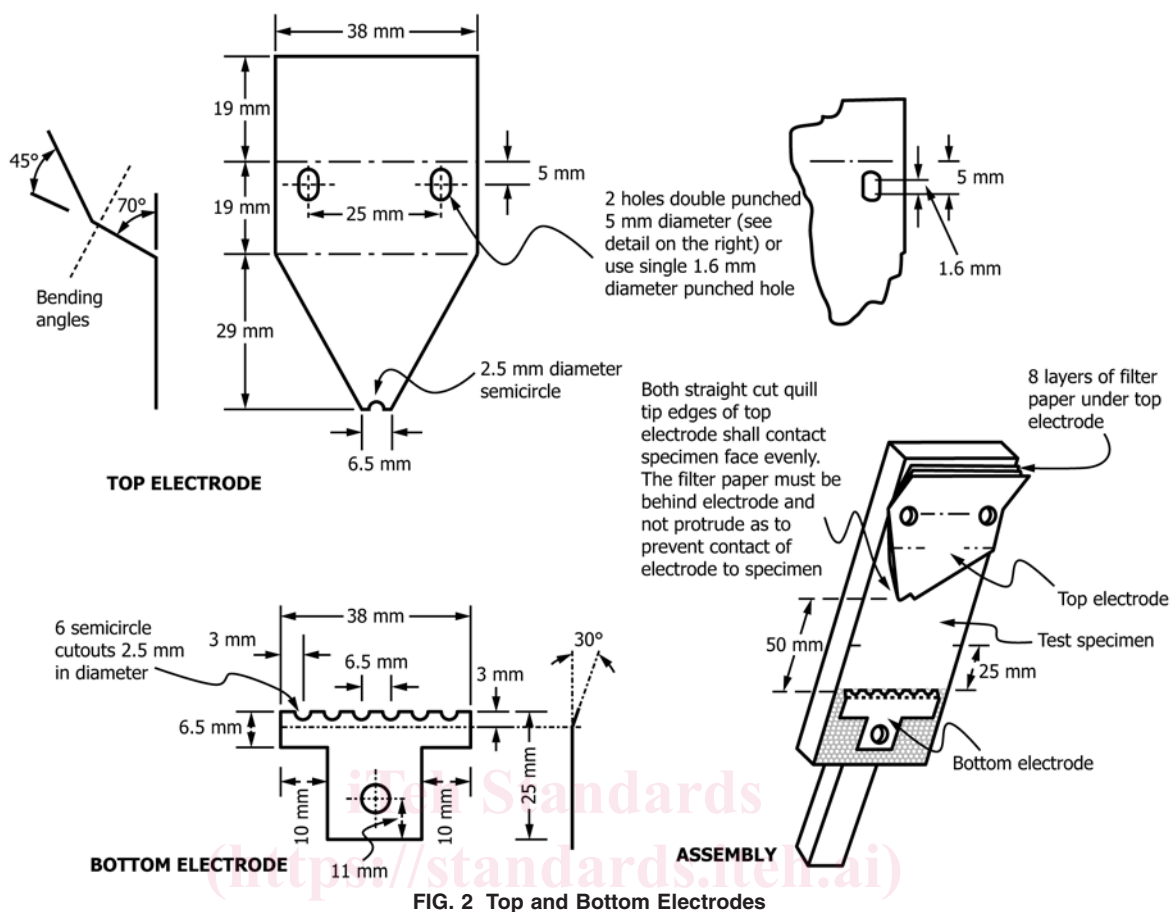

FIG. 2 Top and Bottom Electrodes

direction such as machine direction, cross-machine direction, warp or fill direction (for woven textile reinforced products). (See Fig. 5.)

8.3 *Preparation of Specimens*—Clean the specimen face with a suitable solvent and rinse with distilled water (see Note 3). For specimens to be used in the time-to-track method, do not mechanically destroy, that is, sand, abrade, and so forth, the natural surface finish of the specimen unless otherwise specified. However, with the variable-voltage method, the surface of the test specimens shall be lightly but completely sanded under flowing tap water with 400A-grit wet silicon carbide paper and rinsed with distilled water. Such sanding removes gloss and contaminants to provide a surface that is wet more easily and rapidly by the contaminant. Loss of gloss and slight erosion of the surface usually occurs in service, particularly outdoors. Generously cover the specimen area under the bottom electrode with conductive silver paint (see Note 4) and add the 1-in. (25 mm) tracking reference marks as shown in Fig. 5. For all tests, other than the time-to-track test, soak the test specimens prepared as above for 24 to 48 h in the specified contaminant solution before test.

NOTE 3—The solvent should not soften or otherwise damage the test specimen. Isopropyl alcohol has been found suitable for many materials.

NOTE 4—Conductive silver paint is commercially available from several sources.

8.4 Prepare five specimens for each determination.

9. Procedure

9.1 See Fig. 1.

9.2 Mount and fuse the specimen with the flat test surface on the underside at an angle of 45° from the horizontal as shown in Fig. 1. Insert the contaminant delivery hose midway between eight thicknesses of the filter paper as shown in Fig. 3(a) and Fig. 3(b) and fold back the filter paper “ear” to prevent contaminant from squirting out the sides.

9.3 At the start of each test date, replace all residual liquid in the contaminant supply beaker with fresh contaminant. Cover all beakers to minimize dust and dirt as well as evaporation. Unless otherwise specified, use 0.1 % (by weight) ammonium chloride (reagent grade) and 0.02 % (by weight) nonionic wetting agent (see Note 5) in distilled water. This contaminant solution must have a resistivity between $385 \pm 15 \Omega\text{-cm}$ when measured at $23 \pm 1 \text{ }^\circ\text{C}$.

NOTE 5—Octylphenol ethylene oxide condensate has been found satisfactory. It should be added to a small portion of the water and thoroughly mixed before being added to the larger bulk.

9.4 Adjust the contaminant flow and calibrate as described in Annex A1 to give the flow rate for the voltage to be specified in Table 1.

9.5 After calibration, the start-up procedure differs depending on whether the test specimen is a carry-over from a previous test, or an entirely new specimen.

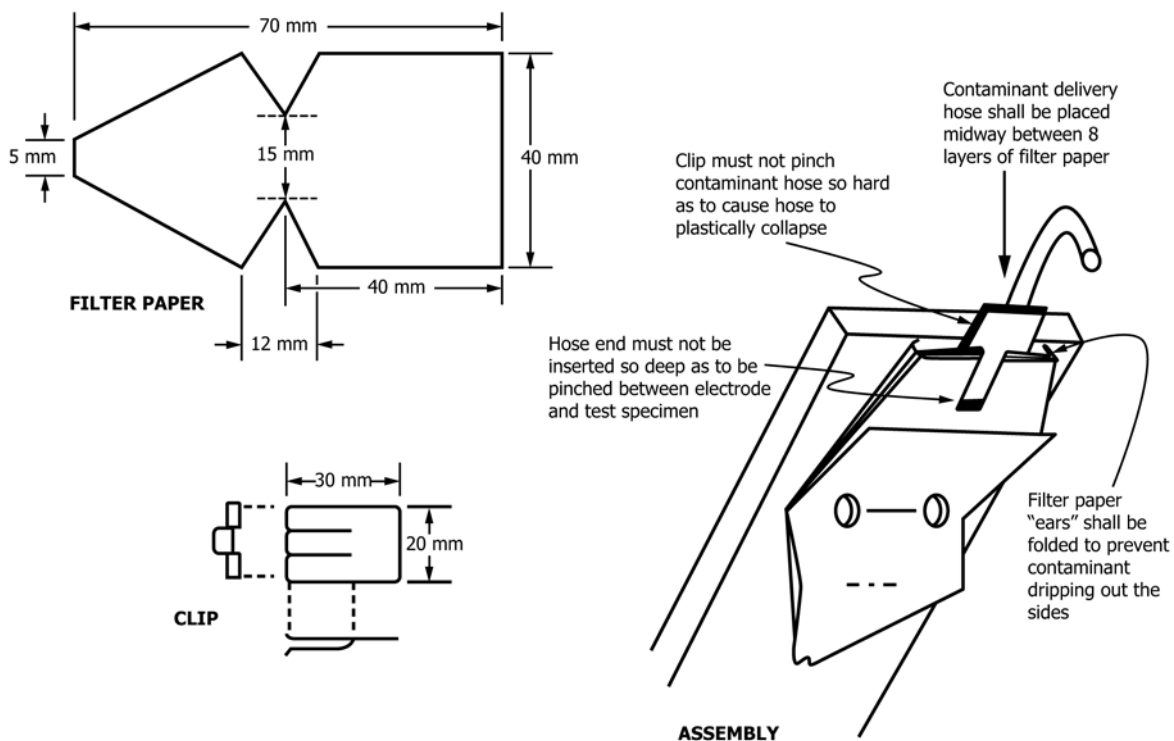

FIG. 3 (a) Filter Paper, Clip, and Method of Fastening



FIG. 3 (b) Nonconductive Mounting Support Plaque Made Out of PTFE, Approximately 6 mm Thick

9.5.1 For a specimen that has never been subjected to voltages and contaminant (that is, new specimen), start the contaminant injection into the filter paper, allowing the fresh contaminant to wet the filter paper thoroughly and replace the old liquid in the tubes and syringes and to flow as a steady stream (Note 6) (not intermittent bursts) across the test specimen face between electrodes. The contaminant must flow from the quill hole in the bottom of the top electrode and shall not squirt out of the sides or top of the filter paper during the

pressure stroke of the pipet. Adjust the specimens so that the contaminant runs down as nearly as possible the center line of the specimen. Avoid drafts on equipment that might cause undue cooling of the specimens or of the water vapor from evaporation of the contaminant. Close the safety gate and apply the appropriate test voltage tabulated in Table 1.

NOTE 6—This steady flow condition shall be observed for 5 min at the normal test contaminant feed rate and not at a manually operated accelerated calibration rate.

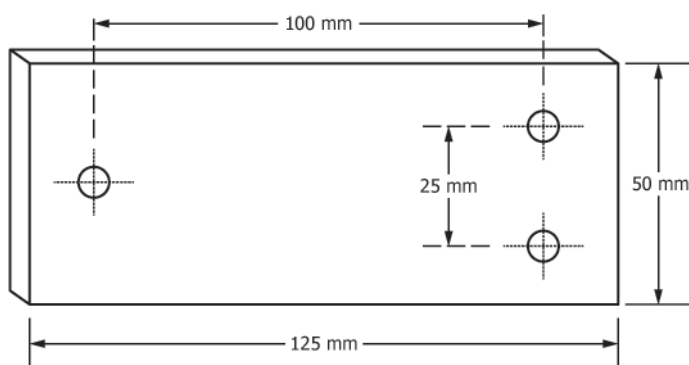

FIG. 4 Test Specimen

9.5.2 For a specimen that is a continuation from a previous test (that is, off test overnight), wash down the test specimen face and filter paper with distilled water in order to remove any contaminant residue from the previous test. Do not change the filter paper. Start the contaminant flow, allowing the fresh contaminant to wet the filter paper thoroughly, and replace the old liquid in the tubes and syringes until a steady contaminant flow (Note 6) is established across the specimen face. Momentarily arrest the contaminant injection into the filter paper, and inject 2 mL of distilled water into the filter paper with a manual syringe. Quickly rewash the specimen face only with distilled water, close the safety gate, start up the contaminant flow, and apply the required voltage. Time is of the essence here, for any prolonged delay will result in a too vigorous and faulty start-up.

9.6 Effective scintillation, small yellow to white (perhaps with some parts blue) arcs, is expected to appear predominantly just above the teeth of the lower electrode within at most a very few minutes after application of the voltage. These discharges are expected to occur in essentially a continuous fashion, although they sometimes “dance” from one tooth to another before finally settling down to cause a small, bright “hot spot” which will start “chewing” on the specimen surface and which will ultimately lead to tracking failure. The condition of effective scintillation can also be observed with a cathode-ray oscilloscope. The signal is sometimes seen on the ungrounded side of the fuse resistor. Proper scintillation is observed as a continual but non-uniform break-up of the 60 Hz current wave over the whole duration of each half cycle. Effective scintillation is critical and if not obtained, then the electrical circuit, the contaminant flow characteristics, and the contaminant conductivity must be carefully checked and adjusted to create the condition for effective scintillation.

9.7 Regardless of whether the start-up is for new specimens or specimens that were left overnight without reaching the 1 in. (25 mm) mark, watch the scintillations for the first 15 min, and periodically at least once every hour thereafter. Thus, the tracking time can be noted, in addition to watching for:

- 9.7.1 Steady scintillation between successive injections,
- 9.7.2 Loss of any contaminant, such as by squirting out of side of filter paper,
- 9.7.3 Whether the contaminant stream down the test specimen face is steady instead of in spurts,

9.7.4 Air bubble leaks into the syringes which would change the contaminant feed rate, and

9.7.5 Stuck syringe pistons.

9.8 Note the time, but do not stop the test to disconnect, any test specimen that has tracked to the 1 in. (25 mm) mark. Stopping the test and removing the voltage, even momentarily, will permit the contaminant to excessively saturate the partially tracked area of other unfailed specimens, with resultant vigorous scintillation after restart. Excessive current in any specimen that continues to track will be taken care of by the fuse resistor.

9.9 If the test is not completed within the working day, the test can be continued the following day if the following precautions are taken:

- 9.9.1 Remove voltage, and stop the contaminant feed.
- 9.9.2 Thoroughly wash down the filter paper with distilled water. Do not replace the filter paper.
- 9.9.3 Thoroughly wash down the specimen face with distilled water.
- 9.9.4 Throw out the contaminant left in the supply beaker and replace with distilled water so that the feed hose sinker will not become encrusted with dried contaminant residue. Do not pump this distilled water into the hose, filter paper, or syringe.

9.10 The method of voltage application and the evaluation of tracking or erosion characteristics depend upon the different test techniques used as described in Sections 10 – 12 and Annex A1.

10. Initial Tracking Voltage Test Method

10.1 For the determination of the initial tracking voltage, apply the voltage between the electrodes in 250 V steps. Hold each voltage for 1 h (unless failure is indicated) before increasing by 250 V to the next step. A starting test voltage must be determined so that tracking failure does not occur sooner than the third step (between 2 and 3 h). Adjust the rate of application of the contaminant so as to maintain effective scintillation at the different voltages (see Table 1). Time can be saved in the determination of the appropriate starting test voltage for a specific material if an intermediate to high voltage is first selected (that is, 3.25 kV). If the specimen fails quickly on the first voltage step, the starting voltage for the next test shall be decreased, usually at least 1 kV. On the other hand, if four steps or more are needed to cause failure, then, increase the initial voltage accordingly. Experience helps in the determination of the appropriate starting voltage.

10.2 The end point of the test is reached at the voltage step where progressive tracking starts. Careful observation is needed to note when isolated markings on the surface first join together and start progressing upward from the bottom electrode. It is important to let this track proceed at least 0.5 in. (13 mm) up the specimen surface before discontinuing the test to make certain that progressive tracking is actually under way. (Some test specimens appear to start tracking and then “clean up.”) Record the voltage at which continuous tracking is established as the “initial tracking voltage.” The elapsed time in the voltage step at which progressive tracking starts is recorded but is not considered to be as significant as the value of the voltage.

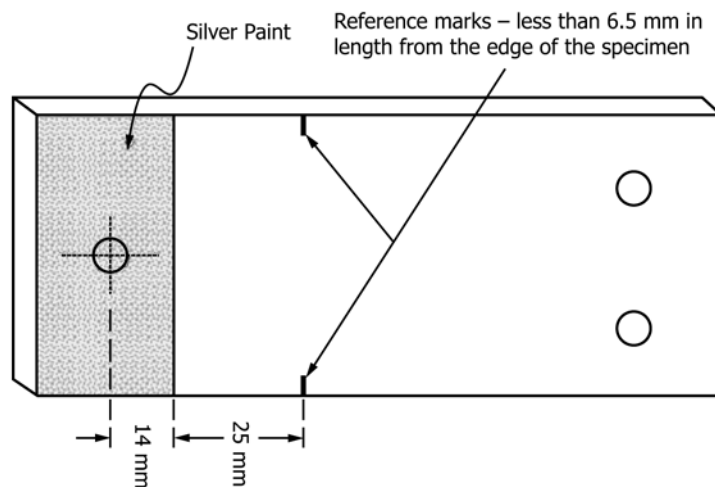

FIG. 5 Test Specimen Showing Location of Conducting Silver Paint and Tracking Reference Marks

TABLE 1 Rates of Contaminant Application

NOTE 1—The rates of contaminant application shown are suitable only for contaminants with a resistivity of $385 \pm 15 \Omega\text{-cm}$ at $23 \pm 1^\circ\text{C}$ on nonporous samples. With porous samples, check the contaminant flow and, if necessary, to increase the contaminant flow somewhat to maintain effective, continual scintillation. Lower contaminant resistivities also will require a higher rate and higher resistivities, a lower rate of contaminant application; this must be determined experimentally. At too high a contaminant rate scintillation will be greatly reduced because the current will flow in the contaminant film without disrupting it. At too low a rate the solution boils away or at the higher voltages is electrostatically removed so that scintillation occurs only at intervals in scattered bursts.^A The tendency for tracking and erosion is increased with a decrease in contaminant resistivity or with the incorporation of a carbonaceous material such as sugar, even though in the latter case the resistivity is not decreased. The chemical nature of the ionizable contaminant is usually of minor importance in respect to tracking but is of major importance in respect to erosion.

Rate of Application of 0.1 % NH_4Cl -0.02 % Wetting Agent, mL/min	Voltage Range, kV	Series Resistor, Ω
0.075	1.0 ^B to 1.75	1 000
0.15	2.0 to 2.75	10 000
0.30	3.0 to 3.75	50 000
0.60	4.0 to 4.75	50 000
0.90	5.0 to 6.0	50 000

^A Mathes, K. N., and McGowan, E. J., "Surface Electrical Failure in the Presence of Contaminants: The Inclined-plane, Liquid-contaminant Test," *Transactions of the AIEE Part I: Communications and Electronics*, 1961.

^B Scintillation at 1 kV is very critical. To achieve scintillation at 1 kV, consider removal of the series resistor and to decrease further the contaminant rate, that is, so that 0.075 mL is applied only once every 2 min. With such slow rates, it is possible also to obtain scintillation at voltages even lower than 1 kV to permit test of relatively poor materials.

10.3 Observe and record the character of the track and the appearance of the test specimen at the end of test. Tracking is, for example, broad, narrow, filamentary, or dendritic (tree-like), with or without deep erosion. The track is brown, or sometimes even white, and sometimes propagates along fiber bundles in the material. The residue in the track is sometimes hard, tough, brittle, powdery, fluffy, and so forth. The specimen itself in the presence of the contaminant and scintillation sometimes changes color, the weave in fabric reinforcement

sometimes gets more pronounced, delamination is sometimes apparent, and so forth.

10.4 The contaminant feed rate shall be constant throughout the test. Calibrate the rate (see Annex A2) at the beginning and end of each test day, or more often if the rate appears to be variable. A feed rate constancy of less than $\pm 5\%$ (preferably $\pm 1\%$) is desirable for the duration of track testing of a specimen.

11. Time-to-track Test Method

11.1 For the time-to-track technique, a constant, specified test voltage (Note 7) is used and the tracking time is recorded. If the test voltage is not specified, try a voltage 750 V lower than the initial tracking voltage as determined in Section 10. All materials in a tracking class must, of course, be tested at the same voltage. The requirements of Table 1 must be met for the test voltage used.

NOTE 7—A test voltage of 2.5 kV has been found generally useful for many track-resistant materials of 0.25 in. (6.0 mm) thickness. For poor tracking materials and thicknesses of 0.063 in. (1.5 mm), preliminary evaluations indicate promise for the use of 1.5 kV with no series resistor. For less than 2.0 kV, scintillation is difficult to maintain. The maximum useful voltage is 6 kV. Precautions should be taken for over 5 kV voltages.

11.2 Since relatively long tracking time sometimes occurs (as much as +10 h), it is important to ensure that the contaminant feed rate remains constant over the total test period. Calibrate the rate (see Annex A2) both before the start and at the end of each test or at least at the beginning and end of each day.

11.3 The time to track a distance of 1 in. (25 mm) above the lower electrode (to the reference mark of Fig. 2) is taken as the failure criterion and is reported in hours and minutes. A taut horizontal string within the test enclosure can be used as a sighting reference to judge whether tracking has progressed to the reference marks. If the time to track is less than 10 min or more than about 15 h, assume the material is out of the voltage range selected, and determine a lower or higher voltage to bring the time to track within the 10 min to 15 h range.