



Designation: D2782 – 20

# Standard Test Method for Measurement of Extreme-Pressure Properties of Lubricating Fluids (Timken Method)<sup>1</sup>

This standard is issued under the fixed designation D2782; the number immediately following the designation indicates the year of original adoption or, in the case of revision, the year of last revision. A number in parentheses indicates the year of last reapproval. A superscript epsilon ( $\epsilon$ ) indicates an editorial change since the last revision or reapproval.

## 1. Scope\*

1.1 This test method covers the determination of the load-carrying capacity of lubricating fluids by means of the Timken Extreme Pressure Tester.

NOTE 1—This test method is suitable for testing fluids having a viscosity of less than about 5000 cSt (5000 mm<sup>2</sup>/s) at 40 °C. For testing fluids having a higher viscosity, refer to Note 5 in 9.1.

1.2 The values stated in SI units are to be regarded as standard. Because the equipment used in this test method is available only in inch-pound units, SI units are omitted when referring to the equipment and the test specimens.

1.3 *This standard does not purport to address all of the safety concerns, if any, associated with its use. It is the responsibility of the user of this standard to establish appropriate safety, health, and environmental practices and determine the applicability of regulatory limitations prior to use.* Specific warning statements are given in 7.1, 7.2, 8.1, 8.2, 9.4, and 9.9.

1.4 *This international standard was developed in accordance with internationally recognized principles on standardization established in the Decision on Principles for the Development of International Standards, Guides and Recommendations issued by the World Trade Organization Technical Barriers to Trade (TBT) Committee.*

## 2. Referenced Documents

2.1 *ASTM Standards:*<sup>2</sup>

D2509 Test Method for Measurement of Load-Carrying Capacity of Lubricating Grease (Timken Method)

D4175 Terminology Relating to Petroleum Products, Liquid Fuels, and Lubricants

<sup>1</sup> This test method is under the jurisdiction of ASTM Committee D02 on Petroleum Products, Liquid Fuels, and Lubricants and is the direct responsibility of Subcommittee D02.L0.11 on Tribological Properties of Industrial Fluids and Lubricates.

Current edition approved Oct. 1, 2020. Published October 2020. Originally approved in 1969. Last previous edition approved in 2017 as D2782 – 17. DOI: 10.1520/D2782-20.

<sup>2</sup> For referenced ASTM standards, visit the ASTM website, www.astm.org, or contact ASTM Customer Service at service@astm.org. For *Annual Book of ASTM Standards* volume information, refer to the standard's Document Summary page on the ASTM website.

## G40 Terminology Relating to Wear and Erosion

### 3. Terminology

3.1 *Definitions:*

3.1.1 *extreme pressure (EP) additive, n*—in a lubricant, a substance that minimizes damage to metal surfaces in contact under high-stress rubbing conditions. **D4175**

3.1.2 *lubricant, n*—any substance interposed between two surfaces for the purpose of reducing friction or wear between them. **G40**

3.1.3 *scoring, n*—in tribology, a severe form of wear characterized by the formation of extensive grooves and scratches in the direction of sliding. **G40**

3.1.4 *wear, n*—damage to a solid surface generally involving progressive loss of material, due to relative motion between that surface and a contacting substance or substances. **G40**

3.2 *Definitions of Terms Specific to This Standard:*

3.2.1 *load-carrying capacity of a lubricant, n*—as determined by this test method, the maximum load or pressure that can be sustained by the lubricant (when used in the given system under specific conditions) without failure of the sliding contact surfaces as evidenced by scoring or seizure or asperity welding.

3.2.2 *OK value, n*—as determined by this test method, the maximum mass (weight) added to the load lever weight pan, at which no scoring or seizure occurs.

3.2.3 *score value, n*—as determined by this test method, the minimum mass (weight) added to the load lever weight pan, at which scoring or seizure occurs.

3.2.3.1 *Discussion*—When the lubricant film is substantially maintained, a smooth scar is obtained on the test block, but when there is a breakdown of the lubricant film, scoring or surface failure of the test block takes place, as shown in Figs. 1 and 2. In its simplest and most recognized form, scoring is characterized by the furrowed appearance of a wide scar on the test block and by excessive pick-up of metal on the surface of the test cup. The form of surface failure more usually encountered, however, consists of a comparatively smooth scar, which shows local damage that usually extends beyond the width of the scar. Scratches or striations that occur in an

\*A Summary of Changes section appears at the end of this standard

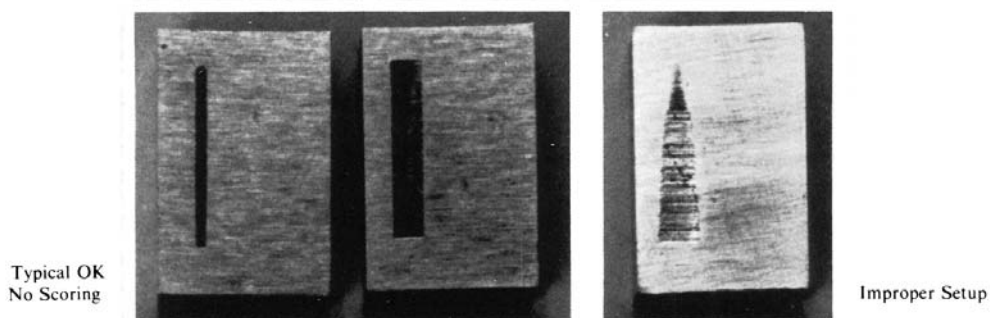

FIG. 1 Test Blocks Showing Various Types of Scar

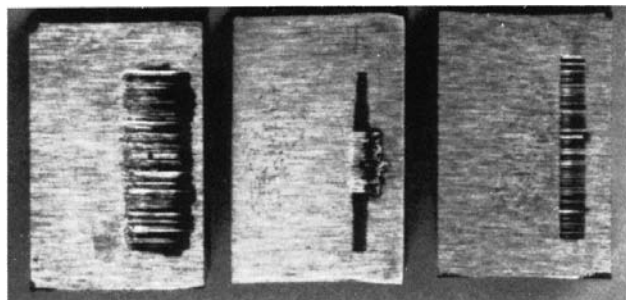

FIG. 2 Scoring

otherwise smooth scar and that do not extend beyond the width of the scar are not considered as evidence of scoring.

3.2.4 *seizure or asperity welding*, *n*—localized fusion of metal between the rubbing surfaces of the test pieces. Seizure is usually indicated by streaks appearing on the surface of the test cup, an increase in friction and wear, or unusual noise and vibration. Throughout this test method the term *seizure* is understood to mean *seizure or asperity welding*.

#### 4. Summary of Test Method

4.1 The tester is operated with a steel test cup rotating against a steel test block. The rotating speed is 123.71 m/min  $\pm$  0.77 m/min (405.88 ft/min  $\pm$  2.54 ft/min), which is equivalent to a spindle speed of 800 r/min  $\pm$  5 r/min. Fluid samples are preheated to 37.8 °C  $\pm$  2.8 °C (100 °F  $\pm$  5 °F) before starting the test.

4.2 Two determinations are made: the minimum load (score value) that will rupture the lubricant film being tested between the rotating cup and the stationary block and cause scoring or seizure; and the maximum load (OK value) at which the rotating cup will not rupture the lubricant film and cause scoring or seizure between the rotating cup and the stationary block.

#### 5. Significance and Use

5.1 This test method is used widely for the determination of extreme pressure properties for specification purposes. Users are cautioned to carefully consider the precision and bias statements herein when establishing specification limits.

#### 6. Apparatus

6.1 *Timken Extreme Pressure Tester*,<sup>3</sup> described in detail in Annex A1 and illustrated in Fig. 3.

6.2 *Sample Feed Device*,<sup>3</sup> for supplying the test specimens with fluid is described in Annex A1.

6.3 *Loading Mechanism*,<sup>3</sup> for applying and removing the load weights without shock at the uniform rate of 0.91 kg/s to 1.36 kg/s (2 lb/s to 3 lb/s). A detailed description is given in Annex A1.

6.4 *Microscope*,<sup>3</sup> low-power (50 $\times$  to 60 $\times$ ) having sufficient clearance under objective to accommodate the test block. It should be fitted with a filar micrometer so that the scar width may be measured with an accuracy of  $\pm$ 0.05 mm ( $\pm$ 0.002 in.).

6.5 *Timer*, graduated in minutes and seconds.

#### 7. Reagents and Materials

7.1 *Acetone*, reagent grade. (**Warning**—Extremely flammable. Harmful when inhaled. See A3.1.)

7.2 *Stoddard Solvent or White Spirit*, reagent grade. (**Warning**—Flammable. See A3.2.)

7.3 *Test Cup*,<sup>3,4</sup> of carburized steel, having a Rockwell Hardness “C” Scale Number of 58 to 62, or a Vickers Hardness Number of 653 to 756. The cups have a width of 0.514 in.  $\pm$  0.002 in., a perimeter of 6.083 in.  $\pm$  0.009 in., a diameter of 1.938 in. + 0.001 in., – 0.005 in. and a maximum radial run-out of 0.0005 in. The axial surface roughness should lie between 0.51  $\mu$ m and 0.76  $\mu$ m (20  $\mu$ in. and 30  $\mu$ in.) C.L.A.

7.4 *Test Blocks*,<sup>3,5</sup> with test surfaces 0.485 in.  $\pm$  0.002 in. wide and 0.750 in.  $\pm$  0.016 in. long, of carburized steel, having a Rockwell Hardness “C” Scale Number of 58 to 62, or a Vickers Hardness Number of 653 to 756. Each block is supplied with four ground faces and the surface roughness should lie between 0.51  $\mu$ m and 0.76  $\mu$ m (20  $\mu$ in. and 30  $\mu$ in.) C.L.A.

<sup>3</sup> The sole source of supply of the apparatus known to the committee at this time is Falex Corp., 1020 Airpark Dr., Sugar Grove, IL 60554. If you are aware of alternative suppliers, please provide this information to ASTM International Headquarters. Your comments will receive careful consideration at a meeting of the responsible technical committee,<sup>1</sup> which you may attend.

<sup>4</sup> Available from Falex Corp., under Part No. F-25061.

<sup>5</sup> Available from Falex Corp., under Part No. F-25001.

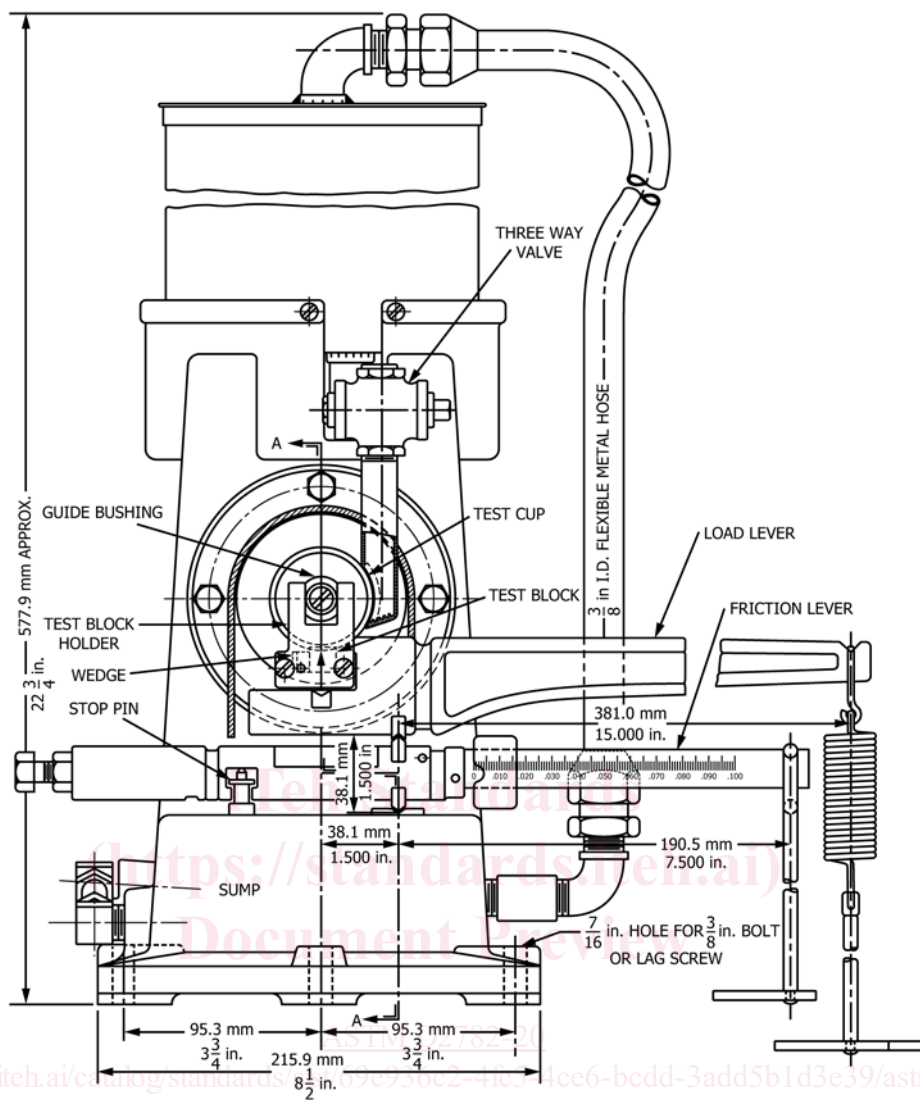

FIG. 3 Timken Tester

## 8. Preparation of Apparatus

8.1 Clean the apparatus with (1) Stoddard solvent or White Spirit, and (2) acetone and blow dry. (**Warning**—Extremely flammable. Harmful when inhaled. See A3.1.) (**Warning**—Flammable. See A3.2.) Flush with approximately 1 L (1 qt) of the fluid to be tested. Discard the flushing fluid. (**Warning**—Since acetone is highly flammable, use the minimum quantity.)

8.2 Select a new test cup and block, wash with Stoddard solvent or White Spirit (**Warning**—Flammable. See A3.2.) and dry with a clean soft cloth or paper. Immediately before use rinse the test cup and block with acetone and blow them dry. Do not use solvents such as carbon tetrachloride or others that may inherently possess load-carrying properties which may effect the results.

NOTE 2—This cleaning may be done in an ultrasonic cleaner.

8.3 Assemble the tester carefully (Fig. 4), placing the test cup on the spindle and making certain that it is well seated, drawing it up firmly but avoiding possible distortion from excessive tightening (Note 3). Place the test block in the test

block holder and adjust the levers so that all the knife edges are in proper alignment. Exercise special care in placing the stirrup of the spring-weight platform assembly (selection of which will depend on the loading device) in the groove of the load-lever arm to avoid premature shock to the test block when the load is applied. To ensure that the test block, test block holder, and lever arms are properly aligned and seated, coat the test block and test cup with the lubricant to be tested, and rotate the machine slowly for a few revolutions either by hand or by suitable control mechanism. When the parts are in alignment, the fluid will be wiped off the cup over its entire width.

NOTE 3—At this point it is recommended that a dial indicator used to check the radial run-out of the cup *in situ* not exceed 0.025 mm (0.001 in.) total indicator movement.

## 9. Procedure

9.1 Fill the reservoir of the tester to within 76 mm (3 in.) of the top (approximately 3 L or 3 qt) with the fluid to be tested. Preheat the fluid to 37.8 °C ± 2.8 °C (100 °F ± 5 °F).

NOTE 4—The fluid may be heated by the use of an immersion heater

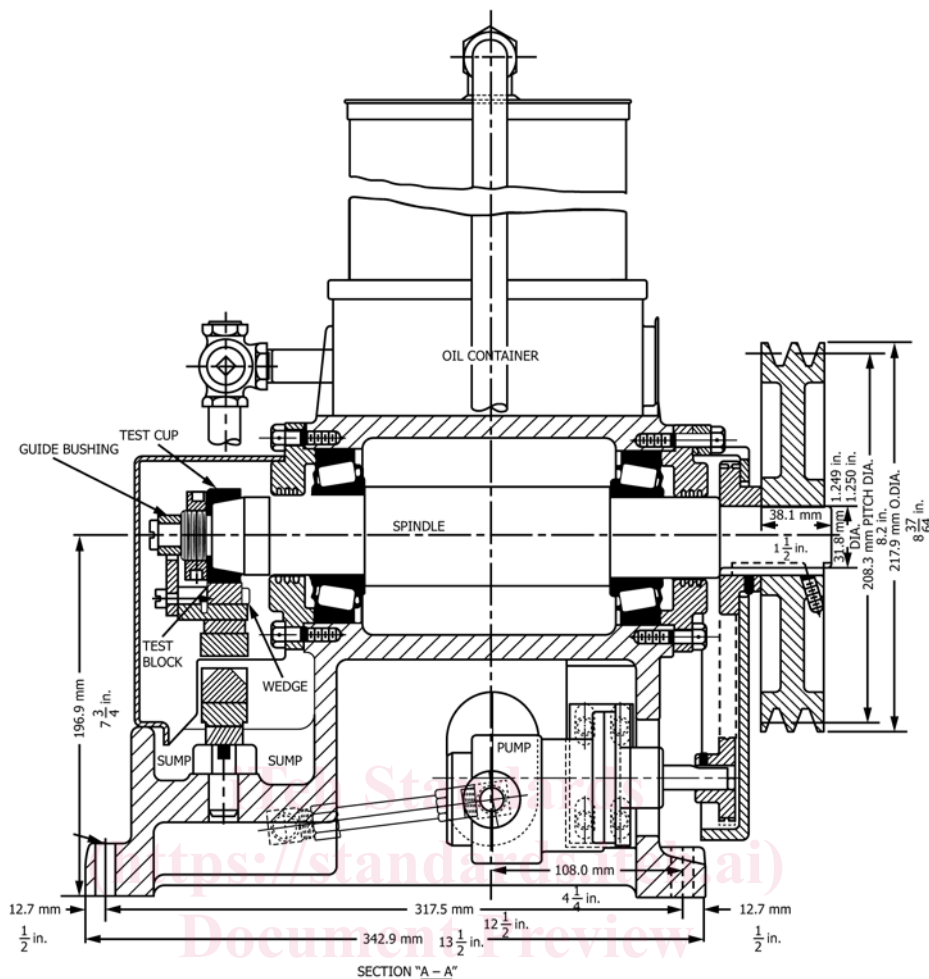

FIG. 3 Timken Tester (continued)

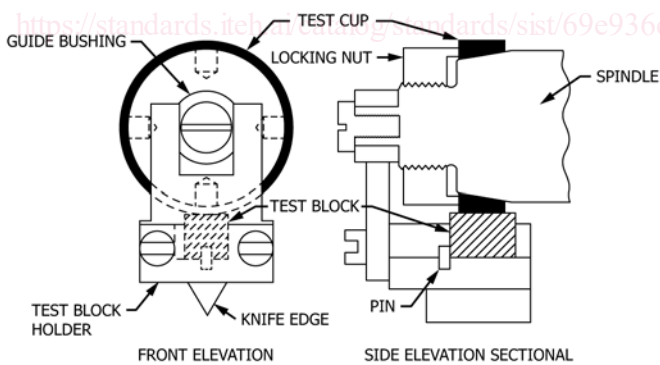

FIG. 4 Assembly of Tester Showing Test Pieces

located in the tester reservoir or by heating the fluid prior to filling the reservoir. If an immersion heater is used, localized overheating must be avoided. This may be done by stirring or by circulating prior to the assembly of the lever arm.

NOTE 5—Fluids having a viscosity above about 5000 cSt (5000 mm<sup>2</sup>/s) at 40 °C often cannot be tested at the prescribed fluid temperature of 37.8 °C ± 2.8 °C (100 °F ± 5 °F) because of inability of the pump to recirculate the fluid at this temperature. However, results from limited cooperative tests, covered in Tables A1.1 and A1.2, indicate that the starting fluid temperature could be increased to 65.6 °C (150 °F) to obtain adequate flow without affecting OK or score values. Testing of such high-viscosity fluids at room temperature in the Test Method D2509

grease feeder also appears valid but may be difficult because of fluid leakage.

9.2 Set the discharge valve at full open. Allow the lubricant to flood the test cup and block. When the sump is about half filled with the fluid, start the motor and run for 30 s to break-in. If the equipment used is equipped with acceleration control, start the motor and increase the spindle speed gradually to achieve 800 r/min ± 5 r/min after 15 s. Run for a further 15 s to complete the break-in.

9.3 After a break-in period of 30 s, start the timer and apply at 8.9 N/s to 13.3 N/s (2 lbf/s to 3 lbf/s), a load that is less than the expected score load. In the absence of a better estimate, a starting load of 30 lbf is recommended. The load-lever arm, spring-weight platform assembly is not considered a part of the applied load. In the event a lower starting load is used, it must be a multiple of 6. Then allow the machine to run at 800 r/min ± 5 r/min for 10 min ± 15 s after load application is initiated, unless a score is detected before that period.

9.4 If, after the load has been applied, scoring is evident by vibration or noise, stop the tester at once, turn off the flow of lubricant, and remove the load. Since the excessive heat developed with deep scoring may alter the surface characteristics of the entire block, discard the test block. (Warning—



The machine and test pieces may be hot at this point and care should be exercised in their handling.)

9.5 If no scoring is detected, allow the tester to run for 10 min ± 15 s from the start of the application of the load. At the end of the 10 min ± 15 s period, reverse the loading device and remove the load from the lever arm. Turn off the motor, allow the spindle to come to rest, then turn off the flow of fluid. Remove the load lever and inspect the condition of the test block surface at 1× magnification. Microscopical observations shall not be used to define when scoring has occurred. The lubricant has failed at the imposed load if the wear scar indicates any scoring or welding.

NOTE 6—A microscope may be used to examine the wear scar for further information as required in 9.9.

9.6 If no score is observed, turn the test block to expose a new surface of contact and, with a new test cup, repeat the test, as in 9.5, at 10 lbf increments until a load that produces a score is reached. At this point decrease the load by 5 lbf for the final determination.

NOTE 7—Before each test in 9.6 – 9.8 cool the fluid in the reservoir to 37.8 °C ± 2.8 °C (100 °F ± 5 °F), cool the shaft to less than 65.6 °C (150 °F), install a new test cup, and turn the test block to expose a new surface of contact. When seizure has occurred, discard the entire test block since excessive heat, developed when scarring occurs, may alter the surface characteristics of the entire block.

9.7 If a score is produced at the 30 lbf load, reduce the load by 6 lbf decrements until no scoring is realized. At this point, increase the load by 3 lbf for the final determination.

9.8 When the wear scar evidence at any load stage makes the definition of the onset of scoring questionable, repeat the test at the same load. If the second test produces a score, record a score rating for this load. Similarly, if the second test produces no scoring, record a no score rating. If the second test again yields a questionable result, simply withhold judgment of the rating at this load stage and test the fluid at the immediately next higher load stage (see Annex A2). Then assign a rating to the load stage in question that is identical to the rating obtained at the immediately next higher load stage employed.

9.9 After the OK value has been determined, remove the test block and wash with Stoddard solvent or White Spirit, rinse with acetone (**Warning**—Extremely flammable. Harmful when inhaled. See A3.1.) (**Warning**—Flammable. See A3.2.), and blow dry. By means of a filar micrometer microscope, measure the width of the scars on those blocks which successfully carried this load. Make all measurements to 0.05 mm (0.002 in.).

## 10. Calculation

10.1 When desired, the contact (unit) pressure that exists between the cup and block at the conclusion of the test can be calculated. Calculate the contact pressure,  $C$ , as follows:

$$C, \text{ psi} = [L(X+G)]/YZ \text{ or } [20(X+G)]/Z \quad (1)$$

$$C, \text{ MPa} = 9.81[L(X'+0.454G)]/Y'Z' \quad (2)$$

where:

- $L$  = mechanical advantage of load-lever arm, 10,
- $G$  = load-lever constant (value is stamped on lever arm of each tester),
- $X$  = mass (weight) placed on the weight pan, lb,
- $X'$  = mass (weight) placed on the weight pan, kg,
- $Y$  = length of test scar (½ in.),
- $Y'$  = length of test scar (12.7 mm),
- $Z$  = average width of test scar, in., and
- $Z'$  = average width of test scar, mm.

10.2 For convenience, contact (unit) pressures in pounds per square inch are listed in Table X3.1.

## 11. Report

11.1 Report the OK and score values in terms of the mass (weights) placed on the weight pan hanging from the end of the load-lever arm; do not include the mass (weight) of the pan assembly. Report the values in multiples of 5 lb above 30 lb and in multiples of 3 lb below 30 lb.

## 12. Precision and Bias<sup>6</sup>

12.1 The precision and this test method as determined by the statistical examination of interlaboratory test results is as follows:

12.1.1 *Repeatability*—The difference between successive results obtained by the same operator with the same apparatus under constant operating conditions on identical test material would, in the long run, in the normal and correct operation of the test method exceed the following values only in one case in twenty.

Repeatability = 30 % of the mean value

12.1.2 *Reproducibility*—The difference between two single and independent results obtained by different operators working in different laboratories on identical test material would, in the long run, exceed the following values only in one case in twenty.

Reproducibility = 74 % of the mean value

NOTE 8—Precision data were obtained from round-robin tests by eleven laboratories on seven paraffinic base oil blends.<sup>6</sup> A table of raw data from the round robin is provided in Appendix X1 for information only.

NOTE 9—The precision values given in Section 12 are considered applicable for samples having, in the long run, an average Timken OK load of 15 lbf minimum.

NOTE 10—The following equipment, as listed in RR:D02-1223,<sup>6</sup> was used to develop the precision statement and no statistically significant differences were found between these pieces of equipment: (1) Falex Timken EP Tester, 1020 Airpark Drive, Sugar Grove, IL 60555. (2) The Timken Company, Canton, OH. To date, no other equipment has demonstrated through ASTM interlaboratory testing the ability to meet the precision of this test. This is not an endorsement or certification by ASTM.

## 13. Keywords

13.1 EP; extreme pressure; load carrying capacity; lubricant; Timken

<sup>6</sup> Supporting data have been filed at ASTM International Headquarters and may be obtained by requesting Research Report RR:D02-1223. Contact ASTM Customer Service at service@astm.org.

ANNEXES

(Mandatory Information)

A1. TIMKEN EXTREME PRESSURE TESTER

A1.1 *Timken Extreme Pressure Tester*,<sup>3</sup> consisting essentially of a steel test cup rotating against a steel test block loaded from below. The test cup is attached to a horizontal spindle mounted in two roller bearings and driven at 800 r/min ± 5 r/min by a 2 hp (1.5 W) synchronous motor. The test block is mounted in a holder upon knife-edge bearings, designed to promote correct alignment and uniform pressure between the test cup and block. The machine must be mounted rigidly as results are affected by vibration. See Table A1.1 and Table A1.2 for test results.

A1.1.1 *Test Block Holder*, fitted with a pin, is provided with a steel wedge to hold the test block in position. It also has a pair of arms which fit around a cast iron guide bushing on the spindle. The bottom of the holder is mounted on knife edges on the load lever.

A1.1.2 *Test Cup Spindle*, tapered to receive the test cup which is locked in position by a locking nut with a left-hand thread. The spindle has a maximum radial run out of 0.013 mm (0.0005 in.); if the assembled cup and spindle has a radial run out greater than 0.025 mm (0.001 in.), test results can be affected. This value would indicate a badly worn or damaged spindle which should be replaced. Periodic checking of an assembled cup and spindle is recommended.

A1.1.3 *Lever System*, consisting of two levers: the upper or load lever and the bottom or friction lever. The load lever carries the test block holder and is mounted on knife edges on the friction lever. The friction lever, pivoted on a knife edge, is provided with a stop at the unloaded end.

A1.1.4 *Load-Lever Constant*—The mechanical advantage of the load lever is 10; that is, 1 lb placed on the notch at the outer end will exert a force of 10 lbf on the test block. The effective weight of the load-lever arm and weight pan system is stamped on the lever arm of each tester.

A1.1.5 *Sample Feed Device*—A 3785 mL (1 gal) capacity reservoir and piping allows gravity flow of test fluid over test cup and block. The reservoir is fitted with an electric heater so that test fluid may be heated. The test fluid flows into a sump and is removed by a pump which returns the fluid to the reservoir. A 20 to 100-mesh screen placed in the sump outlet impedes wear particles from entering the fluid system. Larger screen openings permit the flow of more viscous fluids. A

magnet placed in the sump outlet is also suggested for this purpose. Flow rate of fluid onto the test cup and block is controlled by a three-way valve at the reservoir outlet.

A1.2 *Loading Mechanism*<sup>3</sup>, consists of a power-operated loading platform so arranged that the weights are applied to the end of the load lever at a uniform rate of 0.91 kg/s to 1.36 kg/s (2 lb/s to 3 lb/s), thus eliminating any errors due to a non-uniformity of load application. The weights are applied vertically to the center of the pan at the end of the load lever. Note that the loading rate is a function of the velocity of the loading mechanism and the deflection rate of the weight carrier springs. To measure the loading rate of the mechanism, the following procedure can be used.

A1.2.1 Place a piece of paper on the loading platform. Over it place the weight pan, with a 10 lb or 20 lb (4.54 kg or 9.07 kg) mass (weight) on the pan. An edge of the paper must be left exposed.

A1.2.2 Start the loading platform. When loading begins (indicated by loss of slack in the pan suspension apparatus) begin timing using a stopwatch.

A1.2.3 Grip the paper under the weight pan firmly. When the paper slides out from between the pan and platform, the stopwatch must be stopped. The time elapsed is the time to apply the load on the pan.

A1.2.4 Repeat A1.2.1, A1.2.2, and A1.2.3 at 10 lbf or 20 lbf increments through the maximum load to be used on the tester (smaller increments may be necessary if the loading spring is very non-linear).

A1.2.5 Plot corresponding load versus time values and draw a curve through them. The slope at all points should be between 8.9 N/s to 13.3 N/s (2 lbf/s and 3 lbf/s). Alternatively, the loading rate for each load increment can be calculated as illustrated as follows, for a 20 lbf (89 N) increment between 20 lbf and 40 lbf (89 N and 177.9 N).

Load lbf = N		Time to Apply, s
0	0	0
20	89	7.8
40	177.9	14.6
60	266.9	21.3

TABLE A1.1 Results of 4-Machine, 3-Laboratory Study of Flow Rates of High-Viscosity Fluids in Timken Tester

Fluid Viscosity, cSt (mm <sup>2</sup> /s) at 37.8 °C	Flow Rate, <sup>A</sup> mL/min, at 37.8 °C ± 1.1 °C (100 °F ± 2 °F), Valve Full Open	
	Lowest	Highest
214	1680	2250
648	593	794
1519	256	321
2202	162	209

<sup>A</sup> Calculated from the time for delivery of 900 mL of fluid from full reservoir.

**TABLE A1.2 Viscosities and Estimated Flow Rates for Two Fluids (Low and High Viscosity)**

	Viscosity, cSt SUS			Estimated Flow Rate, <sup>A</sup> mL/min, D2782, Valve Full Open			
	37.8 °C (100 °F)	52.5 °C (125 °F) (ext.)	65.6 °C (150 °F) (ext.)	99 °C (210 °F)	37.8 °C (100 °F)	52.5 °C (125 °F)	65.6 °C (150 °F)
Fluid A	218.5 (1012)	103.1 (470)	53.8 (250)	18.44 (86)	1650–2300	3500–4500	6500–8000
Fluid B	5 505 (25 500)	1 681 (7800)	624 (2900)	105.5 (492)	70–90	240–300	570–800

<sup>A</sup> Estimates from plot of temperature versus flow rate data on the four fluids shown in Table A1.1.

### Rate

$$(20 \text{ to } 40 \text{ lbf}) = \frac{40 \text{ lbf} - 20 \text{ lbf}}{14.6 \text{ s} - 7.8 \text{ s}} = \frac{20 \text{ lbf}}{6.8 \text{ s}} = 2.9 \text{ lbf/s} \quad (\text{A1.1})$$

$$(89 \text{ to } 177.9 \text{ N}) = \frac{177.9 \text{ N} - 89 \text{ N}}{14.6 \text{ s} - 7.8 \text{ s}} = \frac{88.9 \text{ N}}{6.8 \text{ s}} = 13.07 \text{ N/s} \quad (\text{A1.2})$$

All increments must show values in the range from 98.9 N/s to 13.3 N/s (2.0 lbf/s to 3.0 lbf/s).

A1.2.6 Once the loading rate has been established, it can be adjusted, if necessary, by either changing the platform descent rate, or by switching to a spring having different elongation behavior when loaded.

## A2. PROCEDURE FOR ASSIGNING RATING IN CASE OF QUESTIONABLE EVIDENCE OF SCORING

A2.1 The procedure to be followed in the assignment of a score or non-score rating to a load stage at which the evidence of the onset of scoring is questionable is illustrated by considering the following examples. In each example it is assumed that in accordance with 9.8 duplicate results have previously been obtained at the load stage in question, and that the examination of wear scars so produced made the assignment of either score or no-score ratings uncertain.

A2.1.1 If a fluid is tested in duplicate at a load of 40 lbf (177.9 N) in accordance with 9.8, and the examination of both wear scars produced leaves some question regarding the onset of scoring, the operator must next test the fluid at a load of 45 lbf (200.2 N). If no score is observed at this higher load, a no-score rating will be entered for the 40 lbf (177.9 N) load, and testing will proceed at the next usual load increment, for example, 50 lbf (222.4 N). If a score is observed at the 45 lbf (200.2 N) load, a score rating will be entered for the 40 lbf

(177.9 N) load. In this case in accordance with 9.6 the next and final test would be conducted at the 35 lbf (155.7 N) load.

A2.1.2 If a fluid is tested in duplicate at a load of 24 lbf (106.8 N) in accordance with 9.8, and the examination of both wear scars produced leaves some question regarding the onset of scoring, the operator should next test the fluid at a load of 27 lbf (120.1 N). If a score is observed at this higher load, a score rating will be entered for the 24 lbf (106.8 N) load, and testing will proceed at the next usual load decrement, for example, 18 lbf (80.1 N). If no score is observed at the 27 lbf (120.1 N) load, a no-score rating will be entered for the 24 lbf (106.8 N) load. In this case in accordance with 9.7 no further testing is required since no-score ratings are recorded for the 24 lbf and 27 lbf (106.8 N and 120.1 N) loads and scoring had presumably previously been observed at the 30 lbf (133.4 N) load.

## A3. PRECAUTIONARY STATEMENTS

### A3.1 Acetone

Harmful if inhaled. Vapors may cause flash fire.

Keep away from heat, sparks, and open flame.

Keep container closed.

Use with adequate ventilation.

Avoid buildup of vapors and eliminate all sources of ignition, especially nonexplosion-proof electrical apparatus and heater.

Avoid prolonged breathing of vapor or spray mist.

Avoid prolonged or repeated skin contact.

### A3.2 Stoddard Solvent or White Spirit

Vapor may cause flash fire.

Keep away from heat, sparks, and open flame.

Keep container closed.

Use with adequate ventilation.

Avoid buildup of vapors and eliminate all sources of ignition, especially nonexplosion-proof electrical devices and heaters.

Avoid prolonged breathing of vapor or spray mist.

Avoid prolonged or repeated skin contact.