



SLOVENSKI STANDARD

SIST EN 12697-30:2004

01-september-2004

6]li a Ybg_Y'na Ygj'É'DfYg_i gbY'a YfcXY'nUj fc Y'UgZU'fbY'na Ygj'É' \$"XY.'Df]dfUj U
dfYg_i ýUbWj' n'i XUfb]a `n[cý Yj Ub]_ca

Bituminous mixtures - Test methods for hot mix asphalt - Part 30: Specimen preparation
by impact compactor

Asphalt - Prüfverfahren für Heiasphalt - Teil 30: Probenvorbereitung, Marshall-
Verdichtungsgert

iTeh STANDARD PREVIEW

Mlanges bitumineux - Mthodes d'essai pour mlange hydrocarbon a chaud - Partie
30 : Confection d'prouvettes par compacteur a impact

[SIST EN 12697-30:2004](https://standards.iteh.ai/catalog/standards/sist/3c83b67e-fc8b-481d-afed-ab06cd29e2f/sist-en-12697-30-2004)

Ta slovenski standard je istoveten z: [EN 12697-30:2004](https://standards.iteh.ai/catalog/standards/sist/3c83b67e-fc8b-481d-afed-ab06cd29e2f/sist-en-12697-30-2004)

ICS:

93.080.20 Materiali za gradnjo cest Road construction materials

SIST EN 12697-30:2004

en

iTeh STANDARD PREVIEW
(standards.iteh.ai)

SIST EN 12697-30:2004

<https://standards.iteh.ai/catalog/standards/sist/3c83b67e-fc8b-481d-afed-abfebcd29e2f/sist-en-12697-30-2004>

ICS 93.080.20

English version

Bituminous mixtures - Test methods for hot mix asphalt - Part
30: Specimen preparation by impact compactor

Mélanges bitumineux - Méthodes d'essai pour mélange
hydrocarboné à chaud - Partie 30 : Confection
d'éprouvettes par compacteur à impact

Asphalt - Prüfverfahren für Heißasphalt - Teil 30:
Probenvorbereitung, Marshall-Verdichtungsgerät

This European Standard was approved by CEN on 16 April 2004.

CEN members are bound to comply with the CEN/CENELEC Internal Regulations which stipulate the conditions for giving this European Standard the status of a national standard without any alteration. Up-to-date lists and bibliographical references concerning such national standards may be obtained on application to the Central Secretariat or to any CEN member.

This European Standard exists in three official versions (English, French, German). A version in any other language made by translation under the responsibility of a CEN member into its own language and notified to the Central Secretariat has the same status as the official versions.

CEN members are the national standards bodies of Austria, Belgium, Cyprus, Czech Republic, Denmark, Estonia, Finland, France, Germany, Greece, Hungary, Iceland, Ireland, Italy, Latvia, Lithuania, Luxembourg, Malta, Netherlands, Norway, Poland, Portugal, Slovakia, Slovenia, Spain, Sweden, Switzerland and United Kingdom.

SIST EN 12697-30:2004

<https://standards.iteh.ai/catalog/standards/sist/3c83b67e-fc8b-481d-afed-abfebcd29e2f/sist-en-12697-30-2004>



EUROPEAN COMMITTEE FOR STANDARDIZATION
COMITÉ EUROPÉEN DE NORMALISATION
EUROPÄISCHES KOMITEE FÜR NORMUNG

Management Centre: rue de Stassart, 36 B-1050 Brussels

Contents

page

Foreword.....	3
1 Scope	6
2 Normative references	6
3 Principle	6
4 Apparatus	6
4.1 Impact compactor with steel anvil	6
4.2 Impact compactor with wooden pedestal	9
4.3 Compaction mould	10
4.4 Ovens or hot plates	10
4.5 Steel block	10
4.6 Shields, baffle plates or sand baths	10
5 Shape and dimensions of the specimens	14
6 Specimen preparation	14
7 Procedure	14
8 Report	15
Annex A (informative) Device for the measurement of the specimens thickness during compaction.....	16
Bibliography	17

iTeH STANDARD PREVIEW
(standards.itech.ai)

SIST EN 12697-30:2004
<https://standards.itech.ai/catalog/standards/sist/3c83b67e-fc8b-481d-afed-abfebcd29e2f/sist-en-12697-30-2004>

Foreword

This document (EN 12697-30:2004) has been prepared by Technical Committee CEN/TC 227 "Road materials", the secretariat of which is held by DIN.

This European Standard shall be given the status of a national standard, either by publication of an identical text or by endorsement, at the latest by December 2004, and conflicting national standards shall be withdrawn at the latest by August 2005.

Annex A is informative.

This document includes a Bibliography.

This European Standard is one of a series of standards as listed below:

EN 12697-1, *Bituminous mixtures — Test methods for hot mix asphalt — Part 1: Soluble binder content*

EN 12697-2, *Bituminous mixtures — Test method for hot mix asphalt — Part 2: Determination of particle size distribution*

EN 12697-3, *Bituminous mixtures - Test methods for hot mix asphalt - Part 3: Bitumen recovery: Rotary evaporator*

EN 12697-4, *Bituminous mixtures - Test methods for hot mix asphalt - Part 4: Bitumen recovery: Fractionating column*

EN 12697-5, *Bituminous mixtures — Test methods for hot mix asphalt — Part 5: Determination of the maximum density*

EN 12697-6, *Bituminous mixtures — Test methods for hot mix asphalt — Part 6: Determination of bulk density of bituminous specimens*

EN 12697-7, *Bituminous mixtures — Test methods for hot mix asphalt — Part 7: Determination of bulk density of bituminous specimens by gamma rays*

EN 12697-8, *Bituminous mixtures - Test methods for hot mix asphalt - Part 8: Determination of void characteristics of bituminous specimens*

EN 12697-9, *Bituminous mixtures - Test methods for hot mix asphalt - Part 9: Determination of the reference density*

EN 12697-10, *Bituminous mixtures — Test methods for hot mix asphalt — Part 10: Compactability*

EN 12697-11, *Bituminous mixtures - Test methods for hot mix asphalt - Part 11: Determination of the affinity between aggregate and bitumen*

EN 12697-12, *Bituminous mixtures - Test methods for hot mix asphalt - Part 12: Determination of the water sensitivity of bituminous specimens*

EN 12697-13, *Bituminous mixtures — Test methods for hot mix asphalt — Part 13: Temperature measurement*

EN 12697-14, *Bituminous mixtures — Test methods for hot mix asphalt — Part 14: Water content*

EN 12697-15, *Bituminous mixtures — Test methods for hot mix asphalt — Part 15: Determination of the segregation sensitivity*

EN 12697-16, *Bituminous mixtures — Test methods for hot mix asphalt — Part 16: Abrasion by studded tyres*

EN 12697-17, *Bituminous mixtures — Test methods for hot mix asphalt — Part 17: Particle loss of porous asphalt specimen*

- prEN 12697-18, *Bituminous mixtures — Test methods for hot mix asphalt — Part 18: Binder drainage*
- EN 12697-19, *Bituminous mixtures — Test methods for hot mix asphalt — Part 19: Permeability of specimen*
- EN 12697-20, *Bituminous mixtures — Test methods for hot mix asphalt — Part 20: Indentation using cube or Marshall specimens*
- EN 12697-21, *Bituminous mixtures — Test methods for hot mix asphalt — Part 21: Indentation using plate specimens*
- EN 12697-22, *Bituminous mixtures — Test methods for hot mix asphalt — Part 22: Wheel tracking*
- EN 12697-23, *Bituminous mixtures - Test methods for hot mix asphalt - Part 23: Determination of the indirect tensile strength of bituminous specimens*
- EN 12697-24, *Bituminous mixtures — Test methods for hot mix asphalt — Part 24: Resistance to fatigue*
- prEN 12697-25, *Test methods for hot mix asphalt - Part 25: Cyclic compression test*
- prEN 12697-26, *Bituminous mixtures — Test methods for hot mix asphalt — Part 26: Stiffness*
- EN 12697-27, *Bituminous mixtures — Test methods for hot mix asphalt — Part 27: Sampling*
- EN 12697-28, *Bituminous mixtures — Test methods for hot mix asphalt — Part 28: Preparation of samples for determining binder content, water content and grading*
- EN 12697-29, *Bituminous mixtures - Test method for hot mix asphalt - Part 29: Determination of the dimensions of a bituminous specimen*
- EN 12697-30, *Bituminous mixtures — Test methods for hot mix asphalt — Part 30: Specimen preparation by impact compactor*
- EN 12697-31, *Bituminous mixtures — Test methods for hot mix asphalt — Part 31: Specimen preparation by gyratory compactor*
- EN 12697-32, *Bituminous mixtures — Test methods for hot mix asphalt — Part 32: Laboratory compaction of bituminous mixtures by vibratory compactor*
- EN 12697-33, *Bituminous mixtures — Test methods for hot mix asphalt — Part 33: Specimen prepared by roller compactor*
- EN 12697-34, *Bituminous mixtures — Test methods for hot mix asphalt — Part 34: Marshall test*
- prEN 12697-35, *Bituminous mixtures — Test methods for hot mix asphalt — Part 35: Laboratory mixing*
- EN 12697-36, *Bituminous mixtures — Test methods for hot mix asphalt — Part 36: Determination of the thickness of a bituminous pavement*
- EN 12697-37, *Bituminous mixtures — Test methods for hot mix asphalt — Part 37: Hot sand test for the adhesivity of binder on precoated chippings for HRA*
- prEN 12697-38, *Bituminous mixtures — Test methods for hot mix asphalt — Part 38: Common equipment and calibration*
- prEN 12697-39, *Bituminous mixtures — Test methods for hot mix asphalt — Part 39: Binder content by ignition*
- prEN 12697-40, *Bituminous mixtures — Test methods for hot mix asphalt — Part 40: In-situ drainability*
- prEN 12697-41, *Bituminous mixtures — Test methods for hot mix asphalt — Part 41: Resistance to de-icing fluids*
- prEN 12697-42, *Bituminous mixtures — Test methods for hot mix asphalt — Part 42: Amount of foreign matters in reclaimed asphalt*
- prEN 12697-43, *Bituminous mixtures — Test methods for hot mix asphalt — Part 43: Resistance to fuel*

According to the CEN/CENELEC Internal Regulations, the national standards organizations of the following countries are bound to implement this European Standard: Austria, Belgium, Cyprus, Czech Republic, Denmark, Estonia, Finland, France, Germany, Greece, Hungary, Iceland, Ireland, Italy, Latvia, Lithuania,

Luxembourg, Malta, Netherlands, Norway, Poland, Portugal, Slovakia, Slovenia, Spain, Sweden, Switzerland and United Kingdom.

iTeh STANDARD PREVIEW
(standards.iteh.ai)

[SIST EN 12697-30:2004](https://standards.iteh.ai/catalog/standards/sist/3c83b67e-fc8b-481d-afed-abfebcd29e2f/sist-en-12697-30-2004)

<https://standards.iteh.ai/catalog/standards/sist/3c83b67e-fc8b-481d-afed-abfebcd29e2f/sist-en-12697-30-2004>

1 Scope

This European Standard describes methods of moulding specimens from bituminous mixtures by impact compaction. Such specimens are primarily used to determine bulk density and other technological characteristics e.g. Marshall stability and flow according to EN 12697-34.

This European Standard applies to bituminous mixtures (both those made up in a laboratory and those resulting from work site sampling), with an upper aggregate size not larger than 22,4 mm.

2 Normative references

This European Standard incorporates by dated or undated reference, provisions from other publications. These normative references are cited at the appropriate places in the text, and the publications are listed hereafter. For dated references, subsequent amendments to or revisions of any of these publications apply to this European Standard only when incorporated in it by amendment or revision. For undated references the latest edition of the publication referred to applies (including amendments).

EN 12591, Bitumen and bituminous binders – Specifications for paving grade bitumens

EN 12697-10, *Bituminous mixtures — Test methods for hot mix asphalt — Part 10: Compactability*

EN 12697-27, *Bituminous mixtures — Test methods for hot mix asphalt — Part 27: Sampling*

prEN 12697-35, *Bituminous mixtures — Test methods for hot mix asphalt — Part 35: Laboratory mixing*

prEN 13924, Bitumen and bituminous binders – Specifications for hard paving grade bitumens

prEN 14023, Bitumen and bituminous binders – Framework specification for polymer modified bitumens

SIST EN 12697-30:2004
<https://standards.iteh.ai/catalog/standards/sist/5c63b67c-fc86-481d-afed-abf6bcd29e2f/sist-en-12697-30-2004>

3 Principle

To prepare the specimens, tempered asphalt mix, either freshly mixed according to prEN 12697-35 or sampled on site or plant according to EN 12697-27 is transferred into a specified steel compaction mould. The mixture is then compacted in one of the specified impact compactors by the sliding mass being allowed to fall from a specified height with a specified number of blows within a specified time onto the foot of the hammer, located on top of the asphalt specimen. The specimen is then allowed to cool to room temperature.

4 Apparatus

4.1 Impact compactor with steel anvil

4.1.1 General

4.1.1.1 The impact compactor with steel anvil (see Figure 1), a machine-driven apparatus shall comprise the components listed in 4.1.1.2 to 4.1.1.9.

4.1.1.2 Steel base plate, 15 mm thick and about 600 mm × 610 mm, set horizontally on a firm base.

4.1.1.3 Three feet of equal rigidity in the direction of both compression and shear, fitted with rubber buffers corresponding to the mass of the compaction pedestal.

4.1.1.4 Compaction pedestal (see Figure 2) made of cast iron having a mass of at least 100 kg.

4.1.1.5 Clamping device, with eccentric cam (see Figure 1) to hold the compaction mould.

4.1.1.6 Compaction hammer, consisting of a cylindrical guide rod, a sliding mass (see Figure 3), weighing $(4\,550 \pm 20)$ g, and a foot (see Figure 4), weighing $(3\,960 \pm 20)$ g.

4.1.1.7 Chain-driven lifting gear, for the sliding mass, designed so that the length of the free fall is (460 ± 3) mm.

4.1.1.8 Device for counting and recording the number of blows.

NOTE The number of blows should be counted and added.

4.1.1.9 Linear variable differential transformer (optional), as described in annex A, for measuring the specimen thickness during compaction for measuring compactibility in accordance with EN 12697-10.

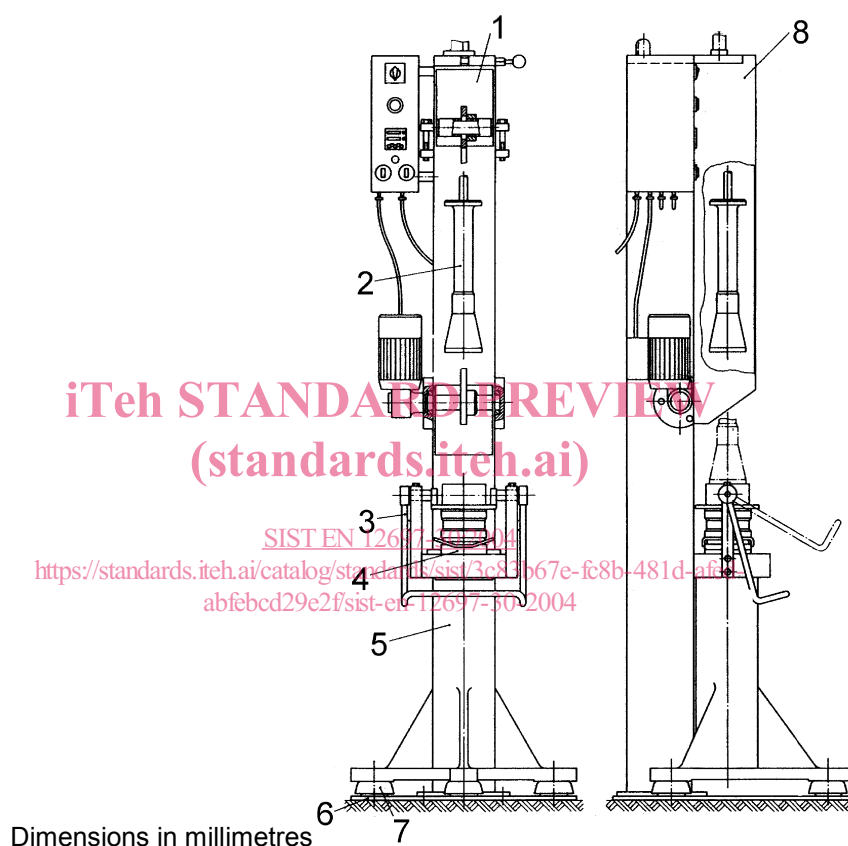

Key

- 1 Basic apparatus with power-driven lifting gear for the sliding mass and impact counter (shown without shielding)
- 2 Compaction hammer with guide rod for the sliding mass
- 3 Eccentric cam for clamping device
- 4 Mould base with compaction mould attached
- 5 Compaction pedestal
- 6 Steel base plate
- 7 Feet
- 8 Shielding

Figure 1 — Diagrammatic sketch of the impact compactor

NOTE See annex A for optional linear variable differential transformer to measure the specimen thickness during compaction.