



Designation: F2700 – 08 (Reapproved 2020)

# Standard Test Method for Unsteady-State Heat Transfer Evaluation of Flame-Resistant Materials for Clothing with Continuous Heating<sup>1</sup>

This standard is issued under the fixed designation F2700; the number immediately following the designation indicates the year of original adoption or, in the case of revision, the year of last revision. A number in parentheses indicates the year of last reapproval. A superscript epsilon ( $\epsilon$ ) indicates an editorial change since the last revision or reapproval.

## 1. Scope

1.1 This test method measures the non-steady state heat transfer through flame-resistant materials for clothing subjected to a continuous, combined convective and radiant heat exposure.

1.1.1 This test method is not applicable to materials that are not flame resistant.

NOTE 1—The determination of a material's flame resistance shall be made prior to testing and done according to the applicable performance or specification standard, or both, for the material's end-use.

1.1.2 This test method does not predict a material's skin burn injury performance from the specified thermal energy exposure. It does not account for the thermal energy contained in the test specimen after the exposure has ceased.

NOTE 2—See [Appendix X4](#) for additional information regarding this test method and predicted skin burn injury.

1.2 This test method is used to measure and describe the response of materials, products, or assemblies to heat under controlled conditions, but does not by itself incorporate all factors required for fire hazard or fire risk assessment of the materials, products, or assemblies under actual fire conditions.

1.3 The values stated in SI units are to be regarded as standard. The values given in parentheses are mathematical conversions to inch-pound or other units that are commonly used for thermal testing.

1.4 *This standard does not purport to address all of the safety concerns, if any, associated with its use. It is the responsibility of the user of this standard to establish appropriate safety, health, and environmental practices and determine the applicability of regulatory limitations prior to use.*

1.5 *This international standard was developed in accordance with internationally recognized principles on standardization established in the Decision on Principles for the Development of International Standards, Guides and Recom-*

*mendations issued by the World Trade Organization Technical Barriers to Trade (TBT) Committee.*

## 2. Referenced Documents

2.1 *ASTM Standards:*<sup>2</sup>

[D123 Terminology Relating to Textiles](#)

[D1776/D1776M Practice for Conditioning and Testing Textiles](#)

[D1777 Test Method for Thickness of Textile Materials](#)

[D3776/D3776M Test Methods for Mass Per Unit Area \(Weight\) of Fabric](#)

[E457 Test Method for Measuring Heat-Transfer Rate Using a Thermal Capacitance \(Slug\) Calorimeter](#)

[F1494 Terminology Relating to Protective Clothing](#)

[F2703 Test Method for Unsteady-State Heat Transfer Evaluation of Flame Resistant Materials for Clothing with Burn Injury Prediction](#)

## 3. Terminology

3.1 *Definitions:*

3.1.1 *breakopen, n*—in testing thermal protective materials, a material response evidenced by the formation of a hole in the test specimen during the thermal exposure that may result in the exposure energy in direct contact with the heat sensor.

3.1.1.1 *Discussion*—The specimen is considered to exhibit breakopen when a hole is produced as a result of the thermal exposure that is at least 3.2 cm<sup>2</sup> (0.5 in.<sup>2</sup>) in area or at least 2.5 cm (1.0 in.) in any dimension. Single threads across the opening or hole do not reduce the size of the hole for the purposes of this test method.

3.1.2 *charring, n*—the formation of a carbonaceous residue as the result of pyrolysis or incomplete combustion.

3.1.3 *dripping, n*—a material response evidenced by flowing of the polymer.

3.1.4 *embrittlement, n*—the formation of a brittle residue as a result of pyrolysis or incomplete combustion.

<sup>1</sup> This test method is under the jurisdiction of ASTM Committee F23 on Personal Protective Clothing and Equipment and is the direct responsibility of Subcommittee F23.80 on Flame and Thermal.

Current edition approved Oct. 1, 2020. Published October 2020. Originally approved in 2008. Last previous edition approved in 2013 as F2700 – 08 (2013). DOI: 10.1520/F2700-08R20.

<sup>2</sup> For referenced ASTM standards, visit the ASTM website, [www.astm.org](http://www.astm.org), or contact ASTM Customer Service at [service@astm.org](mailto:service@astm.org). For *Annual Book of ASTM Standards* volume information, refer to the standard's Document Summary page on the ASTM website.

3.1.5 *heat flux, n*—the thermal intensity indicated by the amount of energy transmitted divided by area and time; kW/m<sup>2</sup> (cal/cm<sup>2</sup>·s).

3.1.6 *ignition, n*—the initiation of combustion.

3.1.7 *melting, n*—a material response evidenced by softening of the polymer.

3.1.8 *unsteady state heat transfer value, n*—in testing of thermal protective materials, a quantity expressed as the time-dependent difference between the incident and exiting thermal energy values normal to and across two defined parallel surfaces of an exposed thermal insulative material.

3.1.9 *heat transfer performance value (HTP), n*—in testing of thermal protective materials, the cumulative amount of energy identified by the intersection of the measured time-dependent heat transfer response through the subject material to a time-dependent, empirical performance curve, expressed as a rating or value; J/cm<sup>2</sup> (cal/cm<sup>2</sup>).

3.1.10 *response to heat exposure, n*—in testing the thermal resistance of thermal protective materials, the observable response of the material to the energy exposure as indicated by breakopen, melting, dripping, charring, embrittlement, shrinkage, sticking, and ignition.

3.1.11 *shrinkage, n*—a decrease in one or more dimensions of an object or material.

3.1.12 *sticking, n*—a material response evidenced by softening and adherence of the material to the surface of itself or another material.

3.1.13 For the definitions of protective clothing terms used in this method, refer to Terminology F1494, and for other textile terms used in this method, refer to Terminology D123.

## 4. Summary of Test Method

4.1 A horizontally positioned test specimen is exposed to a combined convective and radiant heat source with an exposure heat flux of  $84 \pm 2$  kW/m<sup>2</sup> ( $2 \pm 0.05$  cal/cm<sup>2</sup>s).

NOTE 3—Other exposure heat flux values are allowed, however, different exposure conditions have the potential to produce different results. The test facility shall verify the stability of other exposure levels over the material's exposure time interval (used to determine the heat transfer performance value) and include this in the test results report.

4.2 The unsteady-state transfer of heat through the test specimen is measured using a copper slug calorimeter. The change in temperature versus time is used, along with the known thermophysical properties of copper, to determine the respective thermal energy passed through the test specimen.

4.3 A heat transfer performance value of the test specimen is determined as the intersection of the time-dependent cumulative heat response as measured by the calorimeter to a time-dependent, empirical performance curve identified in 10.9.

4.4 Observations of the thermal response of the specimen resulting from the exposure are optionally noted.

## 5. Significance and Use

5.1 This test method is intended for the determination of the heat transfer performance value of a material, a combination of

materials, or a comparison of different materials used in flame-resistant clothing for workers exposed to combined convective and radiant thermal hazards.

5.2 This test method evaluates a material's unsteady-state heat transfer properties when exposed to a continuous and constant heat source. Air movement at the face of the specimen and around the calorimeter can affect the measured heat transferred due to forced convective heat losses. Minimizing air movement around the specimen and test apparatus will aid in the repeatability of the results.

5.3 This test method maintains the specimen in a static, horizontal position and does not involve movement except that resulting from the exposure.

5.4 This test method specifies a standardized  $84 \pm 2$  kW/m<sup>2</sup> ( $2 \pm 0.05$  cal/cm<sup>2</sup>s) exposure condition. Different exposure conditions have the potential to produce different results. Use of other exposure conditions that are representative of the expected hazard are allowed but shall be reported with the results along with a determination of the exposure energy level stability.

5.5 This test method does not predict skin burn injury from the heat exposure.

NOTE 4—See Appendix X4 for additional information regarding this test method and predicted skin burn injury.

## 6. Apparatus and Materials

6.1 *General Arrangement*—The measurement apparatus configuration consists of a combined convective and radiant energy heat source, a water-cooled shutter for exposure control, a specimen and sensor support structure, a specimen holder assembly, a copper calorimeter sensor assembly, and a data acquisition/analysis system. Automation of the apparatus for execution of the measurement procedure is allowed. The general arrangement of the test apparatus configuration is shown in Fig. 1.

6.2 *Gas Supply*—Propane (commercial grade or better) or methane (technical grade or better).

6.3 *Gas Flowmeter*—Any gas flowmeter or rotometer with range to give a flow equivalent of at least 6 L (0.21 ft<sup>3</sup>)/min air at standard conditions.

### 6.4 Thermal Energy Sources:

6.4.1 Two each, Meker or Fisher burners jetted for the selected fuel gas (propane or methane) with a 38 mm (1.5 in.) diameter top and an orifice size of 1.2 mm (<sup>3</sup>/<sub>64</sub> in.) arranged so that the bodies (top section) do not obstruct the quartz lamps and their flame profiles overlap. Dimension tolerances are  $\pm 5$  %.

6.4.2 Nine 500W T3 translucent quartz infrared lamps,<sup>3</sup> connected to a variable electrical power controller, arranged as a linear array with  $13 \pm 0.5$  mm center-to-center spacing set  $125 \pm 10$  mm from the specimen surface.

6.4.2.1 Use of a water-cooled housing for the quartz infrared lamp bank is recommended. This helps to avoid heating

<sup>3</sup> A 500-Watt T3 120VAC quartz infrared heat lamp, product number 21651-1 from Philips Lighting Company has been used successfully in this application.

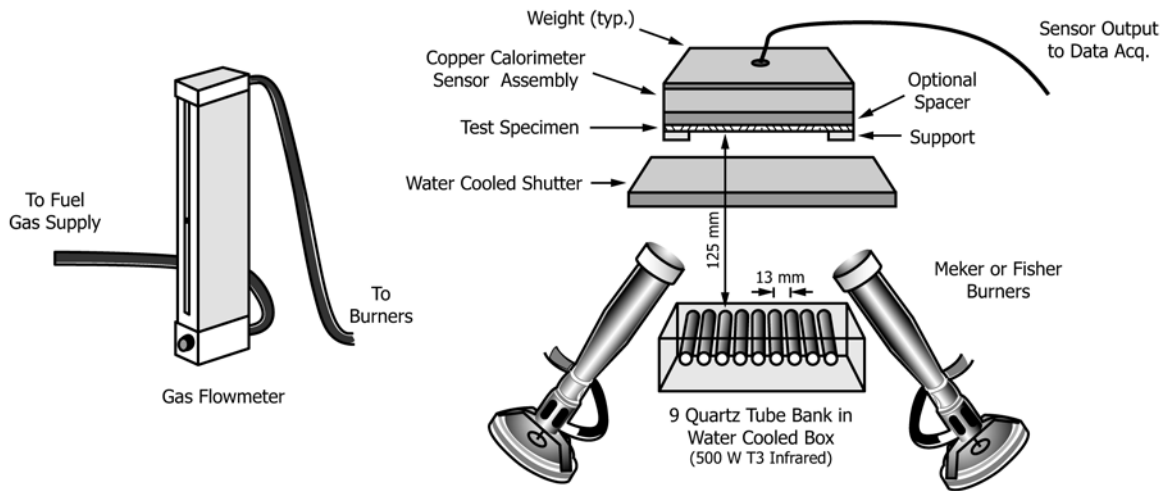

NOTE 1—Note the exposure heat source incorporates two Meker burners and nine quartz infrared lamps.

FIG. 1 Apparatus Used to Measure Heat Transfer Performance of Textile Materials

adjacent mechanical components and to shield the operator from the radiant energy.

#### 6.5 Thermal Sensor:

6.5.1 The transmitted heat sensor is a  $4 \pm 0.05$  cm diameter circular copper slug calorimeter constructed from electrical grade copper with a mass of  $18 \pm 0.05$  g (prior to drilling) with a single ANSI type J (Fe / Cu-Ni) or ANSI type K (Ni-Cr / Ni-Al) thermocouple wire bead (0.254 mm wire diameter or finer—equivalent to 30 AWG) installed as identified in 6.5.2 and shown in Fig. 2 (see Test Method E457 for information regarding slug calorimeters). The sensor holder shall be constructed from nonconductive, heat-resistant material with a thermal conductivity value of  $\leq 0.15$  W/m-K, high temperature stability, and resistance to thermal shock. The board shall be nominally 1.3 cm (0.5 in.) or greater in thickness. The sensor is held into the recess of the board using three straight pins, trimmed to a nominal length of 5 mm, by placing them equidistant around the edge of the sensor so that the heads of the pins hold the sensor flush to the surface.

6.5.1.1 Paint the exposed surface of the copper slug calorimeter with a thin coating of a flat black, high-temperature spray paint with an absorptivity of 0.9 or greater.<sup>4</sup> The painted sensor must be dried and cured, according to the manufacturer's instructions, before use and present a uniformly applied coating (no visual thick spots or surface irregularities). In the absence of manufacturer's instructions, an external heat source, for example, an external heat lamp, shall be used to completely drive off any remaining organic carriers in a freshly painted surface before use.

NOTE 5—Absorptivity of painted calorimeters is discussed in the ASTM Research Report, "ASTM Research Program on Electric Arc Test Method Development to Evaluate Protective Clothing Fabric; ASTM F18.65.01

<sup>4</sup> Zynolyte #635 from Aervoe Industries has been found suitable. Zynolyte is a registered trademark of the Glidden Company.

Testing Group Report on Arc Testing Analysis of the F1959 Standard Test Method—Phase 1."<sup>5</sup>

6.5.2 The thermocouple wire bead is installed in the calorimeter as shown in Fig. 2.

6.5.2.1 The thermocouple wire bead shall be bonded to the copper disk either mechanically or by using high melting point (HMP) solder.

(1) A mechanical bond shall be produced by mechanically deforming the copper disk material (utilizing a copper filling slug as shown in Fig. 2) around the thermocouple bead.

(2) A solder bond shall be produced by using a suitable HMP solder with a melting temperature  $>280$  °C.

NOTE 6—HMP solders consisting of 5 %Sb-95 %Pb (~307 °C melting point) and 5 %Sb-93.5%Pb-1.5 %Ag (~300 °C melting point) have been found to be suitable. The 280 °C temperature minimum identified above corresponds to the point where melting of the solder bond would be experienced with an ~17 s exposure of an 84 kW/m<sup>2</sup> heat flux to a prepared copper calorimeter with a surface area of 12.57 cm<sup>2</sup> and a mass of 18.0 g. A careful soldering technique is required to avoid "cold" solder joints (where the solder has not formed a suitable bond of the thermocouple to the copper disk).

6.5.3 Weight the sensor board assembly so that the total mass is  $1.0 \pm 0.01$  kg and the downward force exhibited by the copper slug sensor surface is uniform.

NOTE 7—Any system of weighting that provides a uniformly weighted sensor is allowed. An auxiliary stainless steel plate affixed to or individual weights placed at the top of the sensor assembly, or both, have been found to be effective.

6.6 Data Acquisition/Analysis System—A data acquisition/analysis system is required that is capable of recording the calorimeter temperature response, calculating the resulting thermal energy, and determining the test endpoint by comparing the time-dependent thermal energy transfer reading to an empirical performance curve.

<sup>5</sup> Supporting data have been filed at ASTM International Headquarters and may be obtained by requesting Research Report RR:F18-1001. Contact ASTM Customer Service at service@astm.org.

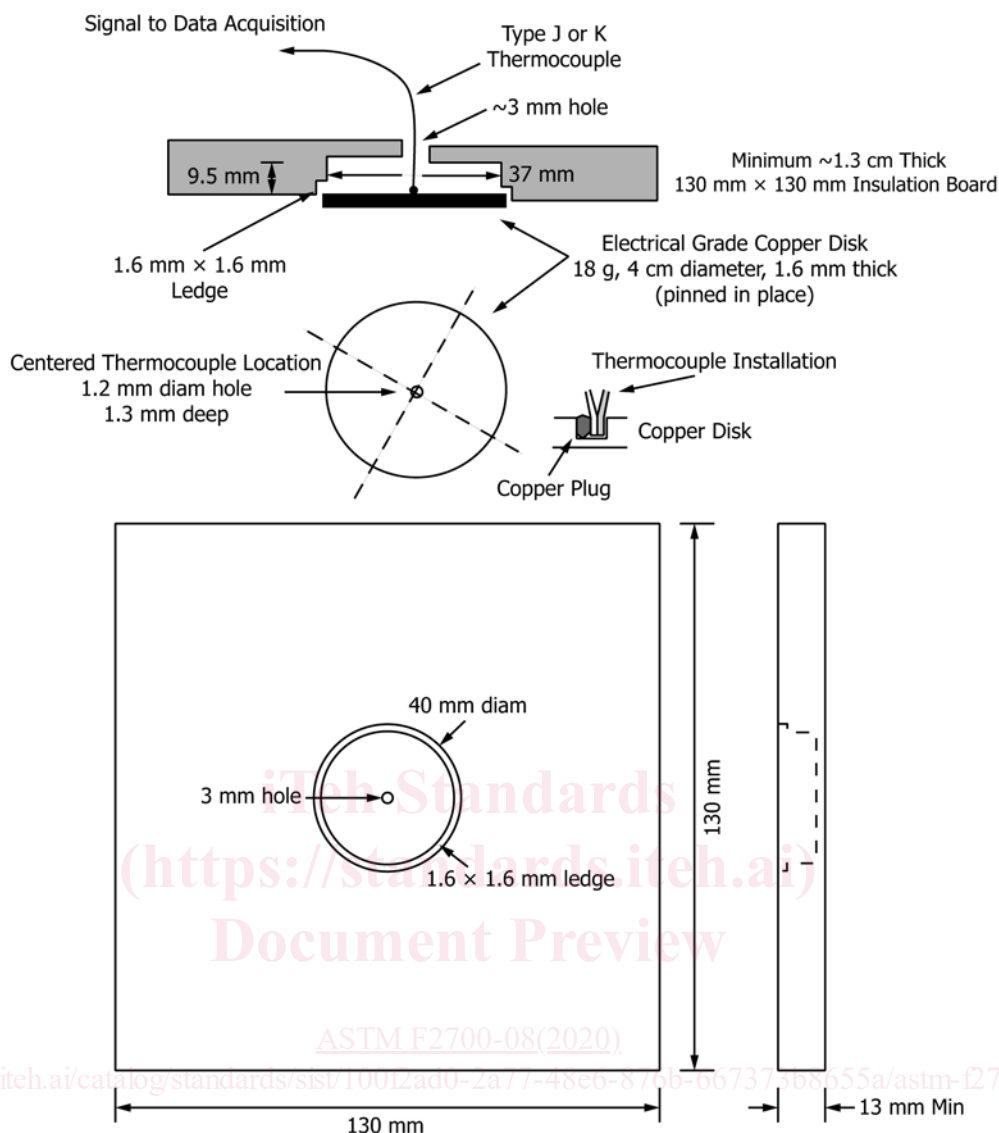

NOTE 1—Secure sensor into supporting insulation board with three sewing pins cut to a nominal 5 mm. All dimensional tolerances are  $\pm 1\%$ .

FIG. 2 Copper Calorimeter Sensor Detail

6.6.1 The data acquisition component shall have a minimum sampling rate of four samples per second for temperatures to 250 °C with a minimum resolution of 0.1 °C and an accuracy of  $\pm 0.75$  °C. It must be capable of making cold junction corrections and converting the millivolt signals from either the type J or K thermocouple to temperature (see NIST Monograph 175 or ASTM MNL 12 Manual on the Use of Thermocouples in Temperature Measurement).<sup>6</sup>

6.7 *Solvents*, alcohol or petroleum solvent for cleaning the copper slug calorimeter.

6.8 *Paint*, flat black, spray type with an absorptivity value  $> 0.90$ .

6.9 *Specimen Holder Assembly*—(See Fig. 3.) Three complete assemblies are desirable for testing efficiency. Alteration is allowed to provide for mechanically restraining a specimen in the holder (see 10.3.2.1).

NOTE 8—The upper specimen mounting plate is designed so that the copper calorimeter assembly fits into the center cutout. An optional spacer component is also designed to fit into the center cutout with the copper calorimeter positioned on top of it. Tolerances for all dimensions are  $\pm 1\%$  to accommodate these arrangement requirements.

6.10 *Shutter*—A manual or computer-controlled shutter is used to block the heat flux from the burner (placed between the

<sup>6</sup> Available from ASTM Headquarters.

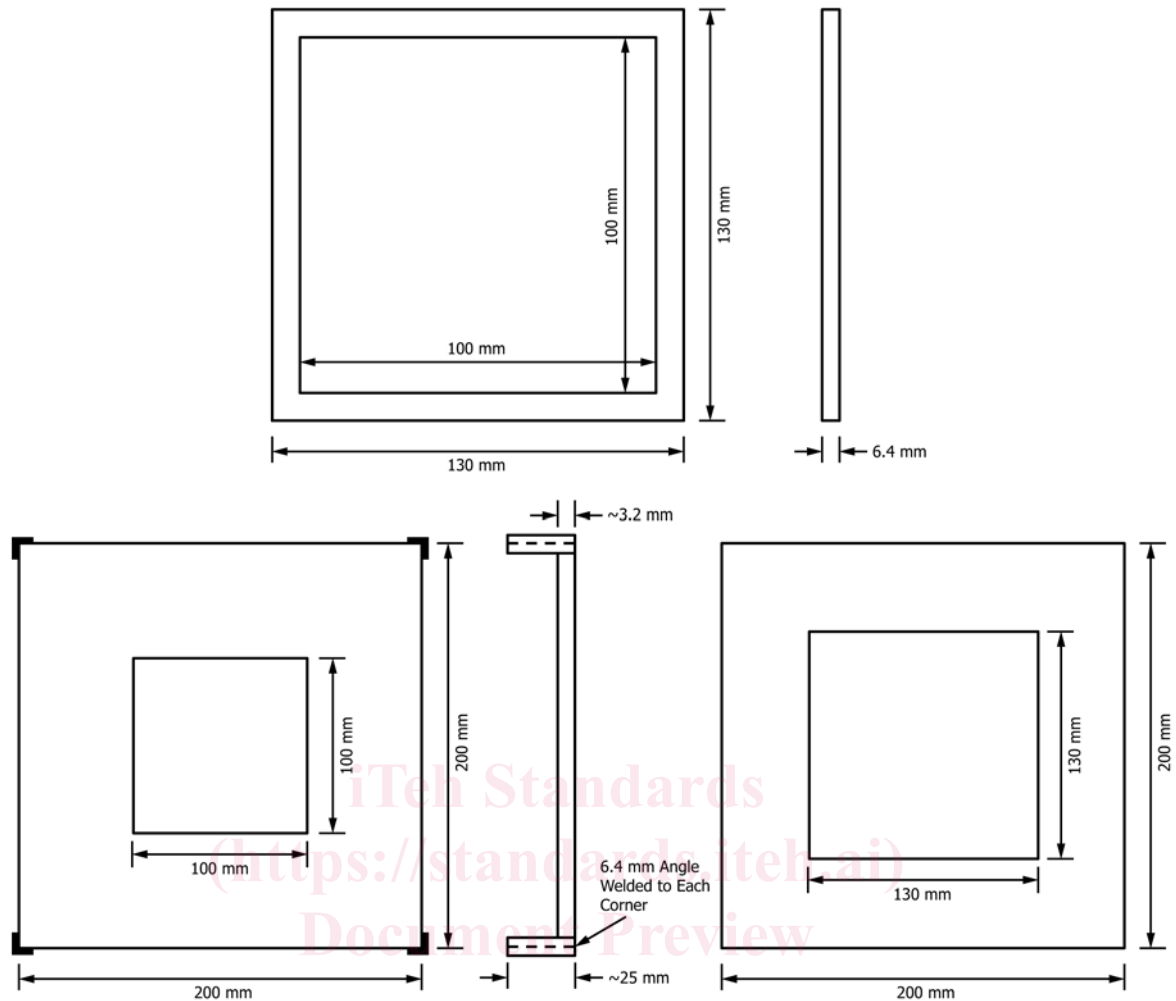

FIG. 3 Details of Specimen Holder Construction, Specimen Holder Parts

[https://standards.iteh.ai/catalog/standards/sist/100f2ad0-2a77-48e6-876b-667373b8655a/astm-f2700-08\(2020\)](https://standards.iteh.ai/catalog/standards/sist/100f2ad0-2a77-48e6-876b-667373b8655a/astm-f2700-08(2020))

specimen holder and the burner). Water-cooling is recommended to minimize radiant heat transfer to other equipment components and to prevent thermal damage to the shutter itself.

## 7. Hazards

7.1 Perform the test in a hood to carry away combustion products, smoke, and fumes. Shield the apparatus or turn off the hood while running the test; turn the hood on to clear the fumes. Maintain an adequate separation between the burner and combustible materials.

7.2 The specimen holder and calorimeter assembly become heated during testing. Use protective gloves when handling these hot objects.

7.3 Use care when the specimen ignites or releases combustible gases. Allow the sample to burn out, or smother it with a flat plate if necessary.

7.4 Refer to manufacturer's Material Safety Data Sheets (MSDS) for information on handling, use, storage, and disposal of materials used in this test method.

7.5 Refer to local codes for compliance on the installation and use of the selected fuel gas (propane or methane).

## 8. Sampling and Specimen Preparation

8.1 *Laboratory Sample*—Select a minimum of a 1.0 m<sup>2</sup> sample size from the material to be tested. Individual test specimens will be produced from this sample.

### 8.2 *Laundering of Laboratory Sample:*

8.2.1 For specimens submitted without explicit test laundering specifications, launder the laboratory sample for one wash and dry cycle prior to conditioning. Use laundry conditions of AATCC Test Method 135 (1, V, A, i).

8.2.1.1 Stitching the edges of the laboratory sample is allowed to minimize unraveling of the sample material.

8.2.1.2 Restoring test specimens to a flat condition by pressing is allowed.

8.2.1.3 If an alternative laundry procedure is employed, report the procedure used.

8.2.2 For those materials that require cleaning other than laundering, follow the manufacturer's recommended practice using one cleaning cycle followed by drying and note the procedure used in the test report.

8.2.3 Record the procedure used in the test report for materials that are submitted with explicit laundering instructions.



8.2.4 Materials designated by the manufacturer not to be laundered or cleaned shall be tested as received.

8.3 *Test Specimens*—Cut and identify eight test specimens from each swatch in the laboratory sample. Make each test specimen 150 by 150 ± 5 mm (6 by 6 ± 1/8 in.) with:

- (a) Two of the sides of the specimen parallel with the warp yarns in the woven material samples;
- (b) The wales in knit material samples; or
- (c) The length of the material in batts or nonwovens.

Do not cut samples closer than 10 % of the material width from the edge; arrange the specimens diagonally across the sample swatch so as to obtain a representative sample of all yarns present.

8.3.1 If the laboratory sample edges have been stitched to reduce unraveling (see 8.2.1.1), test specimens shall be cut so they do not incorporate the stitching material.

8.3.2 Three of the eight test specimens identified above are required for determining average thickness and surface density (see 8.5 and 8.6).

8.4 *Conditioning*—Condition each test specimen for at least 24 h at 21 ± 2 °C (70 ± 5 °F) and 65 ± 5 % relative humidity. The specimens shall be tested within 30 min of removal from the conditioning area.

8.4.1 If any specimens removed from conditioning cannot be tested within 30 min, return them to the conditioning area or seal them in polyethylene bags (or other material with low water vapor permeability) until immediately prior to testing.

8.4.2 Bagged specimens have a 4 h storage limit and are required to be tested within 20 min after removal from the bag.

8.4.3 Bagged specimens that exceed the 4 h storage limit shall be removed from their bag and reconditioned in accordance with 8.4 prior to testing.

8.5 *Determination of Test Specimens Average Thickness*—Determine the three specimens' average thickness identified in 8.3.2 following Test Method D1777. Save these specimens for determining average surface density.

8.6 *Determination of Test Specimens Average Surface Density*—Following the average thickness determination, use the same three specimens to establish an average surface density (mass divided by surface area) following Test Methods D3776/D3776M.

## 9. Preparation, Calibration, and Maintenance of Apparatus

9.1 Remove the sensor assembly and any specimens from the specimen holder and place the apparatus in its measurement position (sample holder directly over the heat source). Position the two Meker or Fisher burners so that the center of each burner head surface is separated by 125 ± 10 mm, located 65 ± 10 mm beneath the specimen holder assembly opening, and subtending an approximate 45° angle from the vertical so that the resulting flames converge at a point immediately beneath the specimen.

9.2 *Heat Flux Calibration*—Calibrating the dual burner/quartz lamp heat source heat flux value is an iterative process that begins with the quartz infrared lamp assembly. After the lamp assembly heat flux is fixed, the burners are adjusted to

obtain an 84 ± 2 kW/m<sup>2</sup> (2.0 ± 0.05 cal/cm<sup>2</sup>s) value for testing. Several calibration passes of both heat source components are typically required to establish the standard value for testing within the specifications described below.

9.2.1 Set the output of the quartz infrared lamp assembly after a minimum 15 min warm-up period to 13 ± 4 kW/m<sup>2</sup> (0.3 ± 0.1 cal/cm<sup>2</sup>s), as measured by an independent NIST traceable Schmidt-Boelter or Gardon type radiant heat flux sensor, positioned in the same geometry as the copper calorimeter sensor in the apparatus, using the lamp's variable power control.

NOTE 9—Fixing the NIST traceable Schmidt-Boelter or Gardon type radiant heat flux sensor into an unused sensor supporting insulation board (see Fig. 2) has proven effective in calibration. Also note that the use of two properly adjusted Meker or Fisher burners and a quartz lamp bank (heat flux output set to 13 kW/m<sup>2</sup>) establishes an approximately 50 % radiant, 50 % convective heat flux at 84 kW/m<sup>2</sup> for testing.

9.2.2 *Burner Gas Supply*—Reduce the pressure on the gas supply to about 55 kPa (8 psig) for proper flame adjustment and remove the Schmidt-Boelter or Gardon type radiant heat flux sensor from the specimen holder (it is used only to calibrate the quartz lamp assembly).

9.2.3 With the quartz lamp bank on (heat flux output set to 13 ± 4 kW/m<sup>2</sup>), start the two burners at a low gas flow rate setting on the gas flowmeter/rotometer. Adjust the burner needle valves so that the flames converge with each other just below the center of the specimen holder (hottest portion of the flames). The flame profile from each burner shall have clearly defined stable blue tips positioned on the burner grids with the larger diffuse blue flames converging in the center.

9.2.4 Increasing or decreasing the heat flux is accomplished by changing the gas flow through the flowmeter/rotometer. Do not adjust the quartz lamp assembly once it has been calibrated. Minor burner needle valve adjustments are typically required to maintain the converged flame profile.

9.2.5 Verify that the copper calorimeter sensor is at room temperature. Ensure the sensor has a clean, black surface without any accumulation of deposits. Otherwise, recondition the sensor surface as described in 9.3.2. Calibration shall not proceed until the sensor temperature has stabilized (less than 1 °C temperature change for a 1 min duration).

9.2.6 With the heat source active, start the data acquisition system then place the sensor onto the specimen holder.

9.2.7 Expose the copper calorimeter to the heat source for at least 10 s.

9.2.8 Stop the data acquisition system and remove the sensor from the holder, placing it away from the apparatus where it is allowed to cool to room temperature.

NOTE 10—Use protective gloves when handling the hot copper calorimeter sensor.

NOTE 11—Using the shutter to control the heat flux calibration exposure in 9.2.6 – 9.2.8 is allowed, but not required.

9.2.9 Calculate the average exposure heat flux value using a sampling interval that starts with the temperature measured at time = 0 (data sample taken just as the sensor is placed onto the sample holder) and ends with the temperature measured at exposure time = 10 s using the computational method identified in 11.1 (sensor response). This value is the measured heat flux.

9.2.10 If the heat flux value determined in 9.2.9 is within the specifications of  $84 \pm 2 \text{ kW/m}^2$  ( $2.0 \pm 0.05 \text{ cal/cm}^2\text{s}$ ), the system is considered calibrated. The actual measured value shall be recorded as the incident heat flux value and shall be used for the determination of the heat transfer performance value in 10.8. If the heat flux value is outside the specifications, adjust the flowmeter/rotometer in the direction required and repeat the calibration process (see 9.2.5 – 9.2.9).

9.2.11 When the correct heat flux is achieved, note the flowmeter/rotometer reading (as well as all other settings for the specific apparatus configuration) as a guide for subsequent adjustments.

### 9.3 Sensor Care:

9.3.1 *Initial Temperature*—Cool the sensor after an exposure with a jet of air (or contact with a cold surface) to room temperature, approximately  $21 \text{ }^\circ\text{C}$  ( $70 \text{ }^\circ\text{F}$ ), prior to positioning the sensor onto the test specimen holder. A measurement shall not proceed until the sensor temperature has stabilized (less than  $1 \text{ }^\circ\text{C}$  temperature change for a 1 min duration).

9.3.2 *Surface Reconditioning*—Wipe the sensor face with a nonabrasive material immediately after each exposure, while hot, to remove any decomposition products that condense on the sensor since these could be a source of error. If a deposit collects and appears to be irregular or thicker than a thin layer of paint, the sensor surface requires reconditioning. Carefully clean the cooled sensor with solvent, making certain there is no ignition source nearby. If bare copper is showing on the sensor surface, completely clean it to bare copper (remove any remaining paint on the surface) and repaint the copper sensor with a thin layer of flat black, high-temperature spray paint identified in 6.5.1.1. Repeat the calibration process (see 9.2.5 – 9.2.9) with the resurfaced sensor before continuing.

9.4 *Specimen Holder Care*—Use dry specimen holders at ambient temperature for test runs. Alternate with several sets of holders to permit cooling between runs, or force cool with air or water. Clean the holder with a non-aqueous solvent if it becomes coated with tar, soot, or other decomposition products.

## 10. Procedure

10.1 The results from a minimum of five test specimen exposures are required for determination of a heat transfer performance value. If additional specimens are taken from the laboratory sample and exposed, they shall be included in the determination of the heat transfer performance value.

10.2 *Calibrate the Heat Source*—Calibrate the system as described in 9.1 and 9.2. Then carefully move the specimen holder assembly and burner away from each other to allow setting up the specimens and sensor in the apparatus for exposure.

10.3 *Specimen Mounting*—Single-layer specimens are mounted either restrained, to restrict heat shrinkage, or relaxed, to permit heat shrinkage. Choose restrained mounting to evaluate barrier performance such as breakopen resistance. Choose relaxed mounting for material shrinkage during exposure. Multiple-layer samples are tested relaxed with the sensor in contact with the back surface of the specimen, unless otherwise specified.

10.3.1 *Optional Spacer*—The optional 6.4 mm ( $\frac{1}{4}$  in.) spacer, if used, is placed between the sensor assembly and the back surface of the specimen. See Fig. 1 for a graphical representation of the appropriate arrangement of the specimen holder (with specimen), spacer, and sensor assembly.

10.3.2 *Restrained Single Layer*—Center the specimen on the lower mounting plate with the surface that will be worn next to the skin facing up and secure all four edges with pressure-sensitive tape of at least 12.7 mm (0.5 in.) width. Attach one edge of the specimen to the plate and then attach the opposite edge of the specimen, using slight tension to remove any sags or wrinkles. Do not pull enough to remove weave crimp or distort a knit fabric or nonwoven structure. Similarly, attach the other two sides with slight tension. The securing tapes will then contact the upper or inside face of the fabric. Place the upper mounting plate on top of the secured specimen.

10.3.2.1 A specimen holder with upper or lower, or both, plate pins<sup>7</sup> or other mechanical restraints is allowed for use in lieu of the pressure-sensitive tape.

10.3.3 *Relaxed Single Layer* (heat shrinkage permitted)—Center the specimen on the lower mounting plate, with the surface to be worn next to the skin facing up. Place the upper mounting plate on top of the specimen. Do not restrain with tape or other mechanical means.

10.3.4 *Multiple Layer Samples*—Place the surface of the material to be used as the outside of the garment face down on the lower mounting plate. Place the subsequent layers on top of each other in the order used in the garment, with the surface to be worn toward the skin facing up. Place the upper mounting plate on top of the layered specimen.

NOTE 12—*Multiple Layer Optional Spacer Use*—The optional spacer is typically used to simulate the average air layer between the inner surface of a worn garment and the wearer. On some multilayer systems, use of the optional spacer can produce test conditions that exceed the valid range of applicability of the literature derived empirical exposure reference model (see Eq 1) used in this test method. This occurs when exposure times exceed ~60 s. The use of the spacer is not recommended for multilayer systems exceeding 60 s exposure times in this configuration.

10.4 Ensure that the sensor has a clean, black surface without any accumulation of deposits. Otherwise, recondition the sensor surface as described in 9.3.2.

10.5 Place the copper calorimeter sensor assembly onto the specimen holder plate (with or without the optional spacer). The black copper slug face shall always be facing downward towards the back of the specimen.

10.6 *Test Exposure*—Place the shutter over the calibrated heat source to block the exposure radiant and convective thermal energy. Center the combined sensor assembly/prepared specimen holder plate over the blocked heat source essentially matching the position used for calibrating the sensor. Remove the shutter to expose the specimen to the heat source and simultaneously start the data acquisition system (sensor data collection).

NOTE 13—Variations using a static sensor assembly and specimen

<sup>7</sup> An example of a lower mounting plate employing pins can be found in Canadian General Standards Board Standard CAN/CGSB-155.20-200 Workwear for Protection Against Hydrocarbon Flash Fire.