



Designation: ~~E477 – 13^{ε1}~~ E477 – 20

Standard Test Method for Laboratory Measurements of Acoustical and Airflow Performance of Duct Liner Materials and Prefabricated Silencers¹

This standard is issued under the fixed designation E477; the number immediately following the designation indicates the year of original adoption or, in the case of revision, the year of last revision. A number in parentheses indicates the year of last reapproval. A superscript epsilon (ϵ) indicates an editorial change since the last revision or reapproval.

^{ε1} NOTE—Equations 9 and 10 were editorially corrected in September 2015.

1. Scope

1.1 This test method covers the laboratory testing of some of the acoustical properties of sound attenuating devices including duct liner materials, integral ducts, and in-duct absorptive straight and elbow silencers used in the ventilation systems of buildings. Procedures are described for the measurement of acoustical insertion loss, airflow generated noise, and pressure drop as a function of airflow.

1.2 Excluded from the scope are reactive mufflers and those designed for uses other than in ventilation systems, such as automobile mufflers.

1.3 This test method includes a provision for a simulated semi-reflective plenum to fit around thin-walled duct and silencer test specimens, since the acoustical environments around such thin-walled specimens can affect the measured insertion loss.

1.4 This method tests the performance of the specimen in well-defined and controlled conditions. If the specimen is installed in the field in any different manner, the results may be different. This standard does not provide estimating procedures for determining the actual installed performance of the specimen under field conditions.

1.5 The values stated in SI units are to be regarded as standard. The values in parentheses are provided for information only.

1.6 *This standard does not purport to address all of the safety concerns, if any, associated with its use. It is the responsibility of the user of this standard to establish appropriate safety, health, and environmental practices and determine the applicability of regulatory limitations prior to use.*

1.7 *This international standard was developed in accordance with internationally recognized principles on standardization established in the Decision on Principles for the Development of International Standards, Guides and Recommendations issued by the World Trade Organization Technical Barriers to Trade (TBT) Committee.*

2. Referenced Documents

2.1 ASTM Standards:²

¹ This test method is under the jurisdiction of ASTM Committee E33 on Building and Environmental Acoustics and is the direct responsibility of Subcommittee E33.08 on Mechanical and Electrical System Noise.

Current edition approved June 1, 2013; July 1, 2020. Published August 2013; October 2020. Originally approved in 1973. Last previous edition approved in 2006 as E477 – 06a; E477 – 13^{ε1}. DOI: 10.1520/E0477-13E01; 10.1520/E0477-20.

² For referenced ASTM standards, visit the ASTM website, www.astm.org, or contact ASTM Customer Service at service@astm.org. For *Annual Book of ASTM Standards* volume information, refer to the standard's Document Summary page on the ASTM website.

C634 Terminology Relating to Building and Environmental Acoustics

2.2 *ANSI Standards:*³

~~S1.1-1994(R2004)~~[S1.1-2013 Acoustical Terminology](#)

~~S1.11-2004(R2009)~~[S1.11-2014/Part 1/IEC 61260:1-2014 Specification—Octave, Half-Octave and Third-Octave Band Filter Sets—Electroacoustics – Octave-Band and Fractional-Octave-Band Filters – Part 1: Specifications](#)

~~S1.43-1997(R2007)~~[Specifications for Integrating-Averaging Sound Level Meters](#)

~~S12.5-2006/ISO 6926:1999(R2011)~~[S12.5-2016/ISO 6926-2016 Requirements for the Performance and Calibration of Reference Sound Sources Used for the Determination of Sound Power Levels](#)

~~S12.51-2012/ISO 3741:2010 (R2017)~~[S12.51-2012/ISO 3741:2010 \(R2017\) Acoustics-Determination of Sound Power Levels of Noise Sources Using Sound Pressure-Precision Method for Reverberation Rooms](#)

2.3 *ASHRAE Documents and Standards:*⁴

~~2009~~[2017 ASHRAE Handbook, Handbook Fundamentals, Chapter 36, Fundamentals, Chapter 37, Measurement and Instruments](#)

~~ANSI/ASHRAE 41.2-2018~~[Standard Methods for Air Velocity and Airflow Measurement](#)

~~ANSI/ASHRAE 41.3-1989~~[41.3-2014 Standard Method for Pressure Measurement \(plus errata dated 5 January 1998\)](#)

2.4 *IEC Standards:*⁵

~~61672-1-2013~~[Electroacoustics – Sound Level Meters – Part 1: Specifications](#)

2.5 *NAIMA Documents and Standards:*⁶

~~Fibrous Glass Duct Liner Standard~~[Standard Publication AH124, Third Edition, 2002](#)

3. Terminology

3.1 *Definitions*—The acoustical terms used in this method are consistent with Terminology **C634**, and ANSI S1.1.

3.2 *Definitions of Terms Specific to This Standard:*

3.2.1 *acoustical duct liner material*—a material that has sound absorptive properties and is attached to the inside wall of a duct to attenuate the sound that propagates down that section of duct.

3.2.2 *airflow generated noise*—the sound created by aerodynamic turbulence caused by air flowing through a device.

3.2.3 *background noise*—the total sound pressure level of all noise sources of interference in a system used for the production, detection, measurement, or recording of a signal, independent of the presence of the signal.

3.2.4 *dynamic insertion loss*—insertion loss measured with air flowing through the test specimen.

3.2.5 *empty duct measurements*—acoustical measurements of sound propagation through the duct system when no test specimen is inserted in this system.

3.2.6 *end reflection loss (ERL)*—sound energy reflected back into the duct at the termination of duct into a large space.

3.2.7 *equivalent diameter of rectangular ducts*— $\{4(W \times H)/\Pi\}^{1/2}$, where W and H are the width and height of the duct specimen connection, respectively.

3.2.8 *forward flow (+)*—(a) the condition where air flows through a sound attenuating device in the same direction as the propagation of sound; (b) the airflow from the sound source chamber to the reverberation room (through the duct system).

3.2.9 *in-duct sound-attenuating devices*—a device or system intended to reduce the sound power propagating inside the duct from one duct section to another.

3.2.10 *insertion loss (IL)*—the reduction in sound power level, in decibels, due to the placement of a sound-attenuating device in the path of transmission, for example, the test duct system, between a sound source and the given location—which in this standard is the reverberation room.

³ Available from American National Standards Institute (ANSI), 25 W. 43rd St., 4th Floor, New York, NY 10036, <http://www.ansi.org>.

⁴ Available from American Society of Heating, Refrigerating, and Air-Conditioning Engineers, Inc. (ASHRAE), 1791 Tullie Circle, NE, Atlanta, GA 30329, <http://www.ashrae.org>.

⁵ Available from International Electrotechnical Commission (IEC), 3, rue de Varembe, 1st floor, P.O. Box 131, CH-1211, Geneva 20, Switzerland, <https://www.iec.ch>.

⁶ Available from North American Insulation Manufacturers Association (NAIMA), 44 Canal Center Plaza, Suite 310, Alexandria, VA 22314, <http://www.naima.org>.

3.2.11 *integral duct*—a duct formed from an integral composite of materials, typically having a porous inner layer to provide sound absorption, with an impervious outer surface.

3.2.12 *reference sound source (RSS)*—a portable, aerodynamic sound source that produces a known stable broadband sound power output.

3.2.13 *reverse flow (-)*—(a) the condition where air flows through a sound attenuating device in the opposite direction to the propagation of sound; (b) the airflow from the reverberation room to the sound source chamber (through the duct system).

3.2.14 *sound source chamber* —an enclosure, near one end of the duct system, in which one or more sources are located for the purpose of generating sound, which is transmitted through the duct system to the reverberation room, located at the other end.

3.2.15 *standard air density (d_s)*—1.202 kg/m³. This corresponds approximately to dry air at 21°C and 101.3 kPa.

3.2.16 *static pressure at a plane of traverse, (P_s)*, Pa—the arithmetic average of the static pressure at points in the plane of traverse.

3.2.17 *static pressure at a point, (P'_s)*, Pa—the pressure measured by the static connection of a pitot tube pointed upstream at that point.

3.2.18 *test run*—pertains to all measurements and calculations at any one setting of the airflow throttling device.

3.2.19 *thin-walled duct*—a duct or silencer whose wall mass or stiffness are low enough to allow significant energy to escape into the surrounding environment. This term applies to ducts whose walls are thinner than 0.6 mm, or are flexible, or are of rigid glass fiber construction.

3.2.20 *total pressure at a plane of traverse, (P_t)*, Pa—the algebraic sum of the velocity pressure at the plane of traverse and the static pressure at the plane of traverse.

3.2.21 *traverse*—a series of measurements made with a pitot tube in a cross section of the test duct, perpendicular to the duct length, in accordance with the *ASHRAE Fundamentals Handbook* Chapter on Measurement and Instruments.

<https://standards.iteh.ai/catalog/standards/sist/a1c2de7e-6886e-436f-953e-c2f9a8c2f127/astm-e477-20>

3.2.22 *velocity pressure at a plane of traverse, (P_v)*, Pa—the square of the average of the square roots of the velocity pressures at points in the plane of traverse.

3.2.23 *velocity pressure at a point, (P'_v)*, Pa—the pressure measured by the differential measurement of a pitot tube pointed upstream at that point.

4. Summary of Test Method

4.1 Insertion loss is measured by comparing the change in sound pressure level due to the insertion of a test specimen into a duct system connecting a reverberation room to a sound source chamber. When insertion loss is measured with air flowing through the test specimen, the measured quantity is dynamic insertion loss. The sound signal is created by a system of loudspeakers within the sound source chamber and transmitted through the system ductwork to the reverberation room. The intent of the method is that the airborne path through the duct is the dominant means of sound transmission between the sound source chamber and the reverberation room. Measurements are made in a series of frequency bands because insertion loss is a function of frequency.

4.2 Noise generated by air flowing through the test specimen is measured in the reverberation room and expressed in terms of a computed sound power level within each frequency band.

4.3 Pressure drop performance is obtained by measuring the static pressure at designated locations upstream and downstream of the test specimen at various airflow settings. The pressure drop and airflow may be measured with a variety of standard acceptable instrumentation such as piezometer rings, flow nozzles, orifices, etc. However, the method described herein is the pitot tube and manometer method.

4.4 It is the intent of this test method that corrections due to background and flanking noise be eliminated or minimized as much as possible. Where corrections are unavoidable, the data are to be marked as corrected and shall indicate the magnitude of the corrections made as described in Sections 9 and 10.

5. Significance and Use

5.1 Specimens tested using this standard, for example, duct silencers, are used to control sound propagation through ventilation ducts. The results gathered from testing specimens to this standard can be used to estimate the reduction in fan sound levels in ducted airflow systems caused by including a sound attenuating device in the system. The device can be a component in a source-path-receiver analysis where calculations are performed to determine the resultant sound level in an occupied space. Correct selection of a sound attenuating device can enable a designer to achieve in-space background noise criteria.

5.2 The insertion loss of a silencer varies with frequency and with the direction and speed of airflow. Because silencers partially obstruct the air path and provide resistance to airflow, two other effects must be quantified: pressure drop and airflow-generated noise. Both increase with increasing air speeds; thus data are required for several airflows to correctly characterize performance.

5.3 The aerodynamic results from testing specimens to the standard can be used as information for the system design engineer to determine the amount of static pressure drop resistance to be overcome by the system fan(s). Guidelines for appropriate maximum allowable pressure drop for a sound attenuating element have been established in the design community and are based on the procedures described herein.

5.4 As stated previously in 1.4 of this test method, the actual performance of a sound attenuating device as installed in an air duct system may be significantly different than reported based on the test procedure herein. This standard does not provide guidance to the user on these system effects.

5.5 Silencers are often designed to be used under conditions which do not duplicate the test set-ups of this standard. Mock-ups and specialized test set-ups to determine performance of sound attenuating devices in non-standard configurations may be based on this test method but cannot be considered to be in full conformance with this test method. See Annex A2 for further information regarding such tests.

6. Test Facilities

6.1 The test facility shall consist of a sound source chamber and a reverberation room coupled together by means of a length of straight or elbow duct. Provisions shall be made in the duct system for inserting either a test specimen, or a section of empty duct having the same interior cross-sectional dimensions at the duct connection points, length, and shape (for elbow testing) as the test specimen. An example of a facility set-up to accommodate straight silencer testing is shown in Fig. 1. An example of a facility set-up to accommodate elbow silencer testing (at various angles) is shown in Fig. 2. Airflow and sound source chamber may be at a fixed or a mobile location within the test facility to accommodate straight and/or elbow silencer testing.

6.2 *Signal Source Chamber*—The sound source chamber shall be a device (as shown schematically in Fig. 1) containing two openings if testing will be conducted with airflow through the test specimen. One opening connects to the test duct and the reverberation chamber, and the other opening connects to the duct from the fan system. The sound source chamber openings for these two ducts shall have the same dimensions (or larger) as the connecting duct. It is recommended that a flared (tapered) opening be provided for the test duct to minimize flow generated noise. The recommended sound source chamber opening dimension is 2 times the duct dimension for the test duct connecting to the reverberation chamber. The sound source (loudspeaker) shall be structurally isolated from the sound source chamber and the connecting duct systems. The sound source chamber shall be large enough to accommodate one or more sound sources with a minimum clearance between the sound source diaphragm and the sound source chamber walls of at least 250 mm in all directions. The recommended minimum volume of the sound source chamber is 10 m³.

6.2.1 The sound source chamber shall be constructed of materials having sufficient sound transmission loss and be adequately isolated from the surrounding environment to minimize noise from the sound source from entering the reverberation chamber by any path other than the duct containing the test specimen. It may be necessary to install sound absorbing materials on the inside surface of the sound source chamber walls to meet the sound source chamber qualification (see 6.2.2).

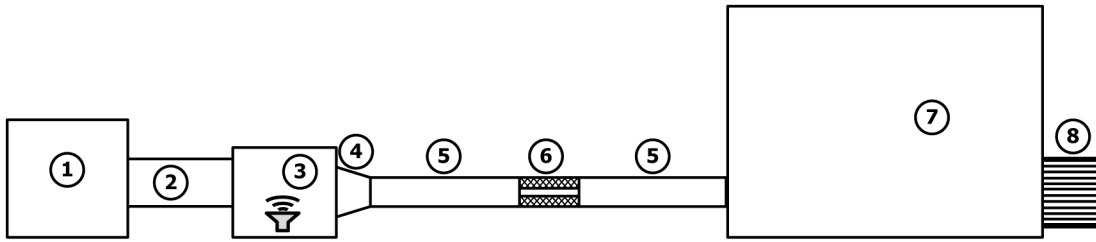

1. Quiet Airflow Source
2. Airflow Measuring Station
3. Signal Source Chamber
4. Transition
5. Test Ductwork with pressure test station
6. Test Specimen
7. Reverberation Room
8. Relief Silencer

FIG. 1 Typical Facility for Rating Straight Duct Silencers With or Without Airflow

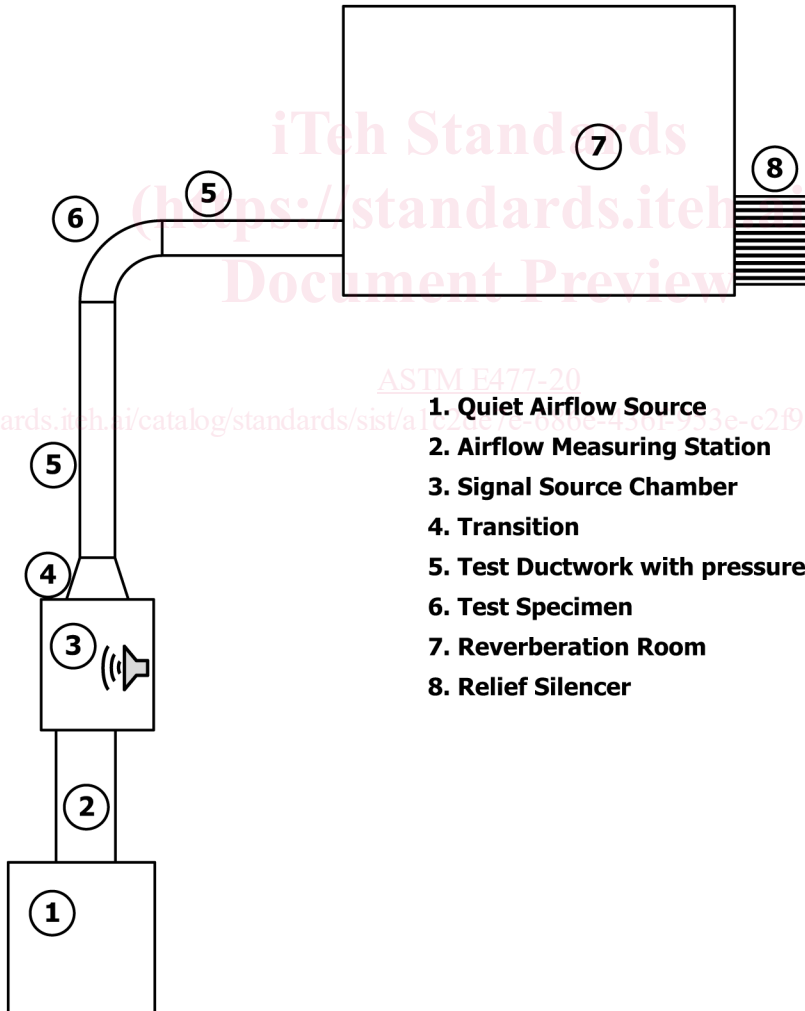

1. Quiet Airflow Source
2. Airflow Measuring Station
3. Signal Source Chamber
4. Transition
5. Test Ductwork with pressure test station
6. Test Specimen
7. Reverberation Room
8. Relief Silencer

FIG. 2 Typical Facility for Rating Elbow Duct Silencers With or Without Airflow

6.2.2 The sound source chamber shall be tested to ensure that the acoustic energy transmitted into the test duct is not affected by the insertion of the test sample by passing the following qualification test.

6.2.2.1 The positioning of the loudspeaker(s) shall be the same during routine testing and sound source chamber qualification.

6.2.2.2 A measurement microphone (meeting the requirements of section 6.6) shall be used to monitor and qualify the sound source chamber. The sound source chamber microphone shall be located at a point centered on the opening of the duct connecting to the reverberation chamber with the microphone placed 150 mm to 300 mm from the opening as shown in Fig. 3. Sound levels in the source chamber shall be measured with the test specimen and the flanking test plug installed as per Fig. A3.1 in Annex A3. Repeat the measurement for the empty duct setup. Compute the sound pressure level difference between the two tests as a function of frequency. The sound source chamber is qualified for measurements according to this standard if the difference between the two sound pressure levels is less than 2 dB in each one-third octave band.

6.2.2.3 If the sound source chamber fails to meet the specified tolerance in one or more frequency bands, modifications to the sound source chamber design are required. Improvements that may be required include adding sound absorptive materials to the sound source chamber walls, increasing the size (volume) of the sound source chamber, or repositioning the loudspeakers(s).

6.3 *System (Between Sound Source Chamber and Reverberation Room)*—The construction of the duct system shall be of adequate mass (1.897 mm or heavier steel) so that any environmental or flanking noises entering the duct system have a negligible effect on the measurements. When testing high insertion loss silencers, it may be necessary to apply a damping material to the outside of the duct walls or increase the transmission loss, or both, by adding one or more layers of gypsum board to the exterior. The interior surface of the duct system shall be smooth and have a low sound absorption coefficient in the frequency range of interest.

6.3.1 The length of the duct system is primarily determined by the requirements of air-flow measurements and is shown in Fig. 4. The test duct length upstream, regardless of the shape of the test specimen and layout of test facility, shall be not less than five equivalent diameters from the entrance to the test specimen. Similarly downstream, it shall be not less than ten duct diameters from the exit of the specimen to the reverberant room, not including the length of any transitions, if airflow is being measured. If airflow is not measured, the downstream length shall be not less than five equivalent duct diameters. The test specimen shall remain in the same position for both the insertion loss and airflow measurements.

6.3.2 The upstream and downstream sections shall have the same cross-sectional dimensions as the entrance and discharge of the test specimen. Any transitions required to connect the duct system to the sound source chamber and reverberation room shall be made upstream and downstream of the required duct length and shall have an included angle of not greater than 15° (slope no greater than 7.5°).

6.3.3 There are occasions when a silencer designed to be used at the termination of a duct system must be tested. Testing of such silencers, mounted at the termination of the duct system or in the reverberation room, shall be considered a special circumstance, and shall be noted as an exception to this test standard in the test report. Full details concerning the mounting and testing must also be included.

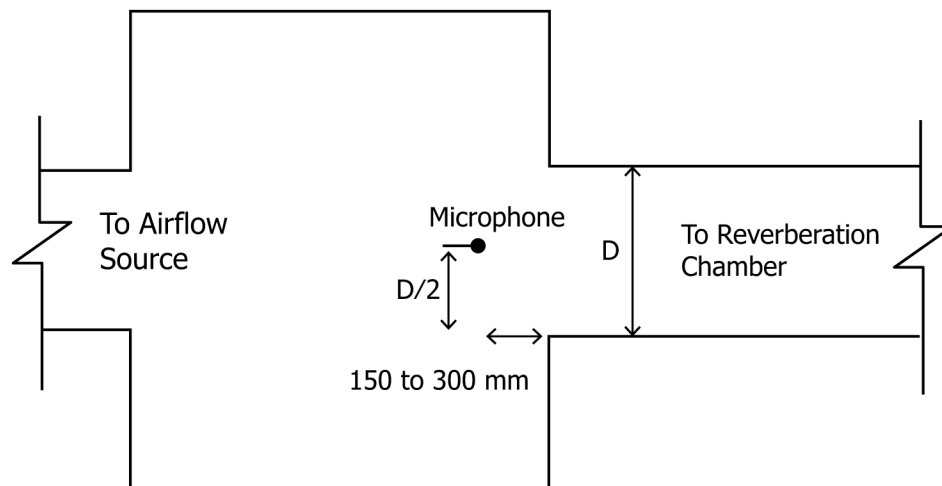

FIG. 3 Sound Source Chamber Microphone Location

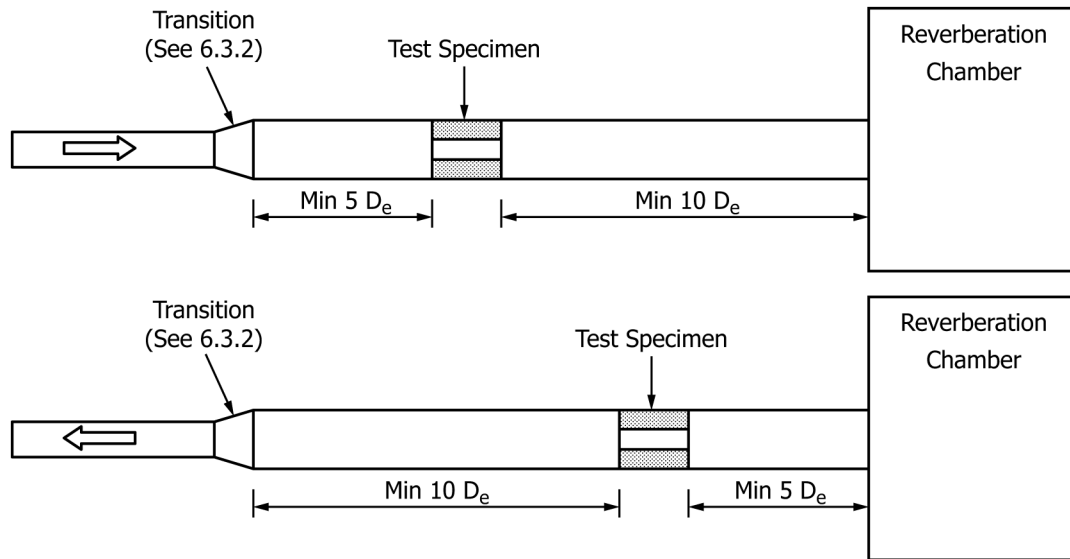

FIG. 4 Test Specimen with Duct and Transition Requirements

6.4 *Reverberation Room*—The acoustic and physical environment of the reverberation room shall be qualified by test to meet the requirements of ANSI Standard S12.51(R2012)/ISO:3741(2010)-S12.51-2012/ISO 3741:2010 (R2017) Section 5.1, 5.5, Annex A, Annex C and Annex E.

6.5 *Test Signal*—The test signal delivered by the loudspeaker system for these tests shall be random pink noise with a continuous frequency spectrum and with equal power per constant percentage bandwidth.

6.5.1 The sound source in the sound source chamber should be a loudspeaker system mounted in a baffle capable of reproducing the lowest test frequency with adequate power. When more than one loudspeaker is used they should be electrically coupled so that they act in phase or in unison in response to a given signal. The loudspeaker should be placed on one side of the sound source chamber such that it does not beam directly into the duct system.

6.5.2 A fixed sound source chamber monitoring microphone meeting the requirements of section 6.6, shall be placed in the sound source chamber to simultaneously monitor the sound pressure levels throughout the insertion loss measurements. The sound source chamber monitoring microphone shall be the same location as the sound source chamber qualification test.

6.5.3 Power shall be applied to the loudspeaker system for a sufficient time to stabilize the loudspeaker system output to meet the requirements of 6.5.2.

6.6 *Acoustical Measurement Apparatus*—Use microphones that are stable and substantially omni-directional in the frequency range of measurement, with a known frequency response for a random incidence sound field. (A 12 mm random-incidence condenser microphone is recommended.) Specifically, microphones, amplifiers, and electronic circuitry to process microphone signals must satisfy the requirements of ANSI S1.43 or IEC 61672 for class 1 sound level meters, except that A, B, and C weighting networks are not required since one-third octave filters are used. All microphones used in testing according to this method shall be of the same type.

6.6.1 *Calibration*—Calibrate each microphone over the whole range of test frequencies as often as necessary to ensure the required accuracy (see ANSI S1.10). A record shall be kept of the calibration data and the dates of calibration.

6.6.2 Calibration checks of the entire measurement system for at least one frequency shall be made at the beginning and end of each day of testing, and if any mechanical, electrical, or environmental changes have occurred. Make the calibration check of the measurement system using an acoustic calibrator that generates a known sound pressure level at the microphone diaphragm and at a known frequency. The class of Calibrator shall be class 1 per ANSI S1.40 or IEC 60942

6.7 *Bandwidth*—The overall frequency response of the filters used to analyze the microphone signals shall, for each test band, conform to the specifications in ANSI S1.11 for a one-third octave band filter set, class 1 or better.

6.8 *Standard Test Frequencies*—Measurements shall be made in all one-third octave bands with mid band frequencies specified in ANSI S1.11 from 50 to 10000 Hz.

7. Apparatus and Methods of Measurement for Airflow and Pressure Drop

7.1 The measurement of airflow may be accomplished by employing a venturi, nozzle or orifice, or any other calibrated flowmeter instrument. A pitot traverse may also be used (see 2.3). Airflow measurements shall be accurate to within 5% of values determined by a pitot traverse in accordance with ANSI/ASHRAE Standard ~~41.2-87~~41.2-2018 at the pressure measurement location between the source chamber and the test specimen for each airflow setting.

7.1.1 The following information is required prior to each test and once every ~~two hours~~2 h during the test to ensure accurate airflow setting and measurements: barometric pressure, dry-bulb temperature and relative humidity in the reverberation room. The airflow is to be recalculated each time new data are taken.

7.2 Pressure drop measurements of the test specimen shall be made for at least three airflow settings in accordance with ANSI/ASHRAE Standard ~~41.3-89~~41.3-2014. These airflow settings shall be broad enough to cover the full design operating range of the specimen.

7.2.1 The pressure measurements shall be made at planes at least two and a ~~half-duct~~half duct diameters (or equivalent diameters for rectangular ducts) upstream from the inlet to the test specimen and at least five duct diameters downstream from the outlet of the test specimen. A piezometer ring or pitot traverse shall be used to ensure accurate pressure measurements.

7.3 Pitot tubes and other flow measuring devices mounted between the test specimen and the reverberation room shall be removed from the duct system during airflow generated noise measurements if their empty duct noise levels in any one-third octave band are within 10 dB of the airflow noise level of the test specimen.

7.4 The total pressure drop across the silencing element shall be calculated from the upstream and downstream total pressures measured directly or calculated from static and velocity pressures measured at the plane of the transverse. This calculation shall be made and reported without correcting for the pressure drop of the substitution duct.

8. Test Specimen

8.1 Installation:

8.1.1 The test specimen shall be installed in the duct system in a manner normally specified for intended use with the specimen, with the air inlet oriented toward the sound source chamber for forward flow tests. For reverse flow tests, the air inlet shall be oriented toward the reverberation room. Unless the run of duct, in shape and length is the same on both sides of the test specimen, the results for both tests, forward and reverse, may depend on the system. The cross section of the duct system at each connection shall conform to the geometry of the inlet and outlet of the specimen.

8.1.1.1 To reduce the effects of structural flanking, the test specimen shall be decoupled from the inlet and outlet duct sections. This can be accomplished by applying a 12 mm bead of mastic material (for example, building duct and conduit sealing compound, rubber gaskets, or similar material) between the flanges that connect the test specimen to the inlet and outlet duct sections. The duct system duct sections may also be decoupled in a similar manner and separated by at least a 6 mm gap between the flanges after they have been bolted or clamped together and the resulting gap between flanges sealed.

8.2 The substitution duct shall be the same sheet metal gage as the system duct except for lined duct specimen tests. In this case, the substitution duct shall be constructed of the same sheet metal gage as the specimen. If the test specimen is an elbow silencer, the substitution elbow duct shall have the same bend angle as the test specimen. In order to minimize attenuation effects, the substitution elbow duct shall be a radius geometry according to:

$$r_{inner} = w_{duct} \quad (1)$$

$$r_{outer} = 2 \times w_{duct} \quad (2)$$

where:

r_{inner} = inner radius,
 r_{outer} = outer radius, and
 w_{duct} = duct width.

8.3 Duct liner materials should be applied to another duct as a separate assembly which then becomes a test specimen. Application should conform to the generally accepted trade methods used (NAIMA) and shall be specified in the report.

8.3.1 The free (inside) area of the lined duct section shall be the same as the free area of the removable duct section; that is, the outside dimensions of the lined duct will be larger than the unlined.

8.4 *Size:*

8.4.1 The smallest dimension should be not less than 610 mm, and may not be less than 150 mm except for prefabricated duct, where the smallest dimension may be that which is normally supplied by the manufacturer. The largest dimensions of the test specimen shall not exceed the limits of the test facility. Transition ducts for the purpose of mating the test specimen geometry to the laboratory duct system geometry may be used, provided that the requirements of 6.3.2 are met. If inlet and outlet transition elements form a part of the test specimen, then this should be fully described in the report.

8.4.2 There is no restriction on the length of prefabricated silencers. Duct liner materials and flexible duct shall be 3000 mm long. In addition to this length, longer specimens of duct liner materials and flexible duct may also be tested and reported. Shorter lengths may be tested, but shall not be reported as being conducted in accordance with this standard.

NOTE 1—The length of duct liner materials and flexible duct controls attenuation. 3000 mm length has been chosen as representative of the length used in actual installations.

9. Measurement of Insertion Loss (With or Without Airflow)

9.1 The purpose of the measurement is to find the change in sound power delivered to the reverberation room before and after the test specimen is inserted into the duct system under conditions of forward and reverse airflow or without airflow. Since the absorption of the reverberation room is the same during the two measurements, the change in sound power level is equal to the change in average sound pressure level in the reverberation room and, by definition, equal to the insertion loss. A sample calculation for each required calculation is provided in Annex A4.

9.2 With the sound source on, and for each condition of test (that is, with and without the test specimen in the duct system, and with and without airflow), measure the average one-third-octave band sound pressure level in the reverberation room ($L_{p,s}$ and $L_{p,empty\ duct}$) and the sound source chamber to the nearest 0.1 dB. All microphone locations used for qualification and sound level measurements shall be the same.

9.2.1 *Sound Source Chamber Monitoring Microphone*—The measured average sound levels in the source chamber with and without the test specimen installed shall not exceed the level difference specified in section 6.2.2.2. If the difference in levels exceed these values the system shall be modified until the measurement requirements are satisfied.

9.2.2 *Reverberation Room Microphone(s)*—No microphone position or point on a traverse shall be less than 1.5 m from any reverberation room surface or less than 0.5 m from any diffuser surface.

9.2.2.1 *Microphone Traverse*—If a traversing microphone is used, the space averaging of the sound data shall be measured using a microphone traversing at a constant speed, not to exceed 1m/s, over a path length greater than or equal to 10.3 m. The microphone traverse path shall not lie in any plane within 10° of any room surface. A whole number of traverses shall be completed during the analyzer measurement time interval.

9.2.2.2 *Fixed Microphones*—If a fixed microphone or microphones are used, measurements shall be made at 6 or more locations that are spaced at least 3.4 m from each other. The entire array of microphones shall not share a common plane.

9.2.3 The averaging time for each one-third-octave band measurement shall be at least 30 s.

9.2.4 A sufficient number of measurements shall be taken so that the 95% confidence interval of the average sound pressure level

is not more than 1 dB in all frequency bands, except for the bands centered at 50, 63 and 80 Hz for which it shall not be more than 2 dB. If a rotating microphone boom is used to qualify the room as described in section 6.4, the same requirements for confidence interval limits shall be met with an appropriate number of successive measurements.

9.3 As with any measurement methodology, it is imperative to ensure that the value being measured is not contaminated by background levels, or that they are accounted for in the final data set. Compare the various measurements with their associated background noise levels (signal-to-noise) to determine the need for system modification or mathematical correction, or both. Practical and reasonable modifications should be made as necessary to avoid using any mathematical corrections whatsoever.

9.3.1 Background noise levels ($L_{p,b}$) in the reverberation chamber shall be measured in accordance with the procedures specified in 9.2 with all sound sources turned off and no airflow through the system. Check the background noise levels before and after any series of sound pressure level measurements, when background noise conditions are noticeably different, or every time there is a duct system rig change. If the measured background noise levels are within 5 dB, the arithmetic average of the values shall be used. If the difference in measured background noise levels is greater than 5 dB, repeat the series of measurements.

9.3.2 Flanking transmission, which is part of the background noise, shall be determined by inserting an obstruction with a high sound transmission loss in the duct system between the test specimen and the reverberation room as shown in Annex A3. The test specimen (duct silencer) shall be in place for the flanking test. The length of the obstruction shall not be more than 20% of the distance between the test specimen and the reverberation room. Flanking sound levels in the reverberation room shall be measured in accordance with the procedures and requirements of section 9.2 and section 6.2.2.2 without airflow. The flanking test shall be conducted for each test specimen. If the flanking sound pressure level is more than 2dB above the background sound pressure level, the flanking sound pressure level shall be corrected according to:

$$Lp_{f'} = 10\log(10^{0.1 \cdot L_{p,f'}} - 10^{0.1 \cdot L_{p,b}}) \quad (3)$$

where:

$L_{p,b}$ = background sound pressure level measured in the reverberation room with the sound source off and no airflow through the silencer in decibels,

$L_{p,f}$ = sound pressure level measured in the reverberation room during the flanking test in decibels, and

$L_{p,f'}$ = sound pressure level measured in the reverberation room during the flanking test corrected for background sound in decibels.

9.3.3 The airflow generated noise levels ($L_{p,gn}$) measured according to section 10.3 shall be compared to the measured background sound levels. If the airflow generated noise sound pressure level is more than 2 dB above the background sound pressure level, the airflow generated noise level shall be corrected according to:

$$Lp_{gn'} = 10\log(10^{0.1 \cdot L_{p,gn}} - 10^{0.1 \cdot L_{p,b}}) \quad (4)$$

where:

$L_{p,gn}$ = sound pressure level in decibels measured in the reverberation room with only airflow through the test specimen (sound source off). Match airflow with test point $L_{p,s}$.

$L_{p,gn'}$ = sound pressure level in decibels measured in the reverberation room with only airflow through the test specimen (sound source off) corrected for background sound. Match airflow with test point $L_{p,s}$. This term is not required for no-flow tests.

9.3.4 The combined corrected background noise levels ($L_{p,b'}$) is composed of the flanking, airflow generated and background noise. The combined corrected background noise ($L_{p,b'}$) shall be calculated according as follows:

$$L_{p,b'} = 10\log(10^{0.1 \cdot L_{p,b}} + 10^{0.1 \cdot L_{p,f'}} + 10^{0.1 \cdot L_{p,gn'}}) \quad (5)$$

9.3.4.1 If the difference between the corrected flanking level and the background level is less than or equal to 2 dB, the corrected flanking level term shall be removed from Eq 5.

9.3.4.2 If the difference between the corrected airflow generated level and the background level is less than or equal to 2dB, the corrected airflow generated level term shall be removed from Eq 5.

9.4 Compare the silenced sound pressure levels ($L_{p,s}$) to the combined corrected background levels ($L_{p,b'}$) determined according to section 9.3.3. Ideally the silenced sound pressure levels should be greater than 10 dB above the combined corrected background levels.

9.4.1 If the measured silenced levels are at least 2 dB above the combined background level, corrections shall be made for each one-third-octave band level at a specific test velocity as follows:

$$L_{p,s'} = 10\log\left(10^{0.1\cdot L_{p,s}} - 10^{0.1\cdot L_{p,b'}}\right) \quad (6)$$

where:

$L_{p,s'}$ = corrected sound pressure level (in specific one-third-octave band) in decibels, and

$L_{p,s}$ = silenced sound pressure level measured in the reverberation room (with or without airflow through the silencer) in decibels.

9.4.1.1 If the measured silenced values are less than 5 dB above the combined background level, the reported values shall be marked with an asterisk to indicate the calculated values have been corrected for background noise.

9.4.2 If the measured silenced levels are less than 2 dB above the combined background level, no corrections are permitted. Reported values shall be marked with two asterisks.

9.5 The insertion loss (IL) in one-third-octave bands is determined by:

$$IL = L_{p,e} - L_{p,s} \quad (7)$$

where:

$L_{p,e}$ = space time averaged sound pressure level measured in the reverberation room for an empty duct configuration with sound source turned on in decibels.

9.5.1 If a correction is required as per section 9.4 then the corrected silenced level ($L_{p,s}$) shall replace the $L_{p,s}$ term in Eq 7 to determine the insertion loss of the silencer. A note shall be included with the data to indicate that it has been corrected for background noise due to flanking, generated noise or background noise and that the actual performance may vary from what is stated.

9.5.2 If the silenced level ($L_{p,s}$) is less than 5 dB above the combined flanking, airflow generated and background noise levels ($L_{p,b'}$), but is still at least 2 dB above the combined background levels, the corrected silenced level ($L_{p,s}$) shall replace the $L_{p,s}$ term in Eq 7. The reported result shall be marked with an asterisk to indicate that the actual performance may vary significantly from what is stated.

9.5.3 If the measured silenced levels are less than 2 dB above the combined flanking, air-flow, and background noise levels, no correction is permitted to the measured silenced level. The IL shall be calculated per Eq 7 and the result shall be marked with two asterisks to indicate that the actual insertion loss will be higher than the reported value.

9.5.4 If the sound source changes in amplitude beyond the limits of section 9.2.1, or modifications are made to the duct system configuration to decrease the flanking transmission or to increase the difference between the silenced levels and the generated noise levels, then the entire test shall be rerun.