



Designation: ~~D1143/D1143M – 07 (Reapproved 2013)~~^{e1} D1143/D1143M – 20

Standard Test Methods for Deep Foundations ~~Foundation Elements~~ Under Static Axial Compressive Load¹

This standard is issued under the fixed designation D1143/D1143M; the number immediately following the designation indicates the year of original adoption or, in the case of revision, the year of last revision. A number in parentheses indicates the year of last reapproval. A superscript epsilon (ϵ) indicates an editorial change since the last revision or reapproval.

This standard has been approved for use by agencies of the U.S. Department of Defense.

^{e1} NOTE—Editorially corrected the title of Figure 2 in June 2018.

1. Scope ~~Scope~~*

1.1 The test methods described in this standard measure the axial deflection of ~~a~~ an individual vertical or inclined deep foundation element or group of elements when loaded in static axial compression. These methods apply to all ~~deep foundations, types of deep foundations, or deep foundation systems as they are practical to test. The individual components of which are referred to herein as piles, elements~~ that function as, or in a manner similar to ~~driven piles or cast-in-place piles, to, drilled shafts, cast-in-place piles (augered cast-in-place piles, barrettes, and slurry walls), driven piles, such as pre-cast concrete piles, timber piles or steel sections (steel pipes or wide flange beams) or any number of other element types, regardless of their method of installation, and installation.~~ Although the test methods may be used for testing single piles or pile groups. ~~The elements or element groups, the test results may not represent the long-term performance of a deep foundation, the entire deep foundation system.~~

1.2 This standard provides minimum requirements for testing deep ~~foundations~~ foundation elements under static axial compressive load. Plans, specifications, and/or provisions prepared by a qualified engineer may provide additional requirements and procedures as needed to satisfy the objectives of a particular test program. The engineer in ~~responsible~~ charge of the foundation ~~design, design~~ referred to herein as the ~~Engineer, engineer~~, shall approve any deviations, deletions, or additions to the requirements of this standard. (Exception: the test load applied to the testing apparatus shall not exceed the rated capacity established by the engineer who designed the testing apparatus).

1.3 This standard allows the following test procedures:

Procedure A	Quick Test	8.1.2
Procedure B	Maintained Test (Optional)	8.1.3
Procedure C	Loading in Excess of Maintained Test (Optional)	8.1.4
Procedure D	Constant Time Interval Test (Optional)	8.1.5
Procedure E	Constant Rate of Penetration Test (Optional)	8.1.6
Procedure F	Constant Movement Increment Test (Optional)	8.1.7
Procedure G	Cyclic Loading Test (Optional)	8.1.8

1.3 Apparatus and procedures herein designated “optional” may produce different test results and may be used only when approved by the ~~Engineer, engineer~~. The word “shall” indicates a mandatory provision, and the word “should” indicates a recommended or advisory provision. Imperative sentences indicate mandatory provisions.

¹ This test method is under the jurisdiction of ASTM Committee D18 on Soil and Rock and is the direct responsibility of Subcommittee D18.11 on Deep Foundations. Current edition approved June 15, 2013/Sept. 15, 2020. Published July 2013/October 2020. Originally approved in 1950. Last previous edition approved in 2007 as D1143 – 07 (2013)^{e1}. DOI: 10.1520/D1143_D1143M-07R13E01; 10.1520/D1143_D1143M-20.

*A Summary of Changes section appears at the end of this standard

1.4 A qualified geotechnical engineer should interpret the test results obtained from the procedures of this standard so as to predict the actual performance and adequacy of pile elements used in the constructed foundation. ~~See Appendix X1 for comments regarding some of the factors influencing the interpretation of test results.~~

1.5 A qualified engineer (qualified to perform such work) shall design and approve all loading apparatus, loaded members, ~~support frames, and support frames.~~ The geotechnical engineer shall design or specify the test procedures. The text of this standard references notes and footnotes which provide explanatory material. These notes and footnotes (excluding those in tables and figures) shall not be considered as requirements of the standard. This standard also includes illustrations and appendices intended only for explanatory or advisory use.

1.6 Units—The values stated in either SI units or inch-pound units are to be regarded separately as standard. The values stated in each system ~~are may not necessarily be exact equivalents; therefore, to ensure conformance with the standard, each system shall be used independently of the other, and other.~~ Combining values from the two systems shall not be combined; may result in non-conformance with the standard.

1.7 The gravitational system of inch-pound units is used when dealing with inch-pound units. In this system, the pound [lbf] represents a unit of force [weight], while the unit for mass is ~~slugs, slug.~~ The rationalized slug unit is not given, unless dynamic [F=ma] calculations are involved.

1.8 All observed and calculated values shall conform to the guidelines for significant digits and rounding established in Practice **D6026**.

1.8.1 The procedures used to specify how data are collected, recorded and calculated in this standard are regarded as the industry standard. In addition, they are representative of the significant digits that should generally be retained. The procedures used do not consider material variation, purpose for obtaining the data, special purpose studies, or any considerations for the user's objectives; and it is common practice to increase or reduce significant digits of reported data to be commensurate with these considerations. It is beyond the scope of this standard to consider significant digits used in analysis methods for engineering data.

1.9 The method used to specify how data are collected, calculated, or recorded in this standard is not directly related to the accuracy to which the data can be applied in design or other uses, or both. How one applies the results obtained using this standard is beyond its scope.

1.10 The text of this standard references notes and footnotes that provide explanatory material. These notes and footnotes (excluding those in tables and figures) shall not be considered as requirements of the standard.

1.11 This standard offers an organized collection of information or a series of options and does not recommend a specific course of action. This document cannot replace education or experience and should be used in conjunction with professional judgment. Not all aspects of this standard may be applicable in all circumstances. This ASTM standard is not intended to represent or replace the standard of care by which the adequacy of a given professional service must be judged, nor should this document be applied without consideration of a project's many unique aspects. The word "Standard" in the title of this document means only that the document has been approved through the ASTM consensus process.

1.12 *This standard does not purport to address all of the safety concerns, if any, associated with its use. It is the responsibility of the user of this standard to establish appropriate safety, health, and environmental practices and determine the applicability of regulatory limitations prior to use.*

1.13 *This international standard was developed in accordance with internationally recognized principles on standardization established in the Decision on Principles for the Development of International Standards, Guides and Recommendations issued by the World Trade Organization Technical Barriers to Trade (TBT) Committee.*

2. Referenced Documents

2.1 ASTM Standards:²

² For referenced ASTM standards, visit the ASTM website, www.astm.org, or contact ASTM Customer Service at service@astm.org. For *Annual Book of ASTM Standards* volume information, refer to the standard's Document Summary page on the ASTM website.



[D653 Terminology Relating to Soil, Rock, and Contained Fluids](#)

[D3740 Practice for Minimum Requirements for Agencies Engaged in Testing and/or Inspection of Soil and Rock as Used in Engineering Design and Construction](#)

[D5882 Test Method for Low Strain Impact Integrity Testing of Deep Foundations](#)

[D6026 Practice for Using Significant Digits in Geotechnical Data](#)

[D6760 Test Method for Integrity Testing of Concrete Deep Foundations by Ultrasonic Crosshole Testing](#)

[D7949 Test Methods for Thermal Integrity Profiling of Concrete Deep Foundations](#)

[D8169 Test Methods for Deep Foundations Under Bi-Directional Static Axial Compressive Load](#)

2.2 *American National Standards:*³

[ASME B30.1 Jacks](#)

[ASME B40.100 Pressure Gages/Gauges and Gauge Attachments](#)

[ASME B89.1.10.M Dial Indicators \(For Linear Measurements\)](#)

3. Terminology

3.1 ~~Definitions~~—~~Definitions~~For—For common definitions of common technical terms used in this standard, see—refer to Terminology [D653](#).

3.2 *Definitions of Terms Specific to This Standard:*

3.2.1 *anchor, n*—a device or deep foundation element or elements designed to resist the upward movement.

3.2.2 ~~cast-in-place~~ *cast-in-place pile, n*—a deep foundation ~~unit~~element made of cement grout or concrete and constructed in its final location, for example, drilled shafts, bored piles, caissons, ~~auger-cast~~augered cast-in-place piles, pressure-injected footings, etc.

3.2.3 ~~deep foundation,~~ *foundation element, n*—a relatively slender structural element that transmits some or all of the load it supports to soil or rock well below the ground surface, such as a steel pipe ~~pile or concrete~~concrete-filled drilled ~~shaft~~shaft.

3.2.4 *driven pile, n*—a deep foundation ~~unit~~element made of preformed material with a predetermined shape and size and typically installed by impact hammering, vibrating, or ~~pushing~~-jacking.

3.2.5 *failure load, n*—for the purpose of terminating an axial compressive load test, the test load at which rapid continuing, progressive movement occurs, or at which the total axial movement exceeds 15 % of the ~~pile~~element diameter or width, or as specified by the engineer.

3.2.6 *gage or gauge, n*—an instrument used for measuring load, pressure, displacement, strain or such other physical properties associated with load testing as may be required.

3.2.7 *telltale rod, n*—an unstrained metal rod extended through the test ~~pile~~element from a specific point to be used as a reference from which to measure the change in the length of the loaded ~~pile~~element.

3.2.8 *toe, n*—the bottom of a deep foundation element, sometimes referred to as tip or base.

3.2.9 *wireline, n*—a steel wire mounted with a constant tension force between two supports and used as a reference line to read a scale indicating movement of the test ~~pile~~element.

4. Summary of Test Method

4.1 This standard provides minimum requirements for testing deep foundation elements under static axial compressive load. The test is a specific type of test, most commonly referred to as deep foundation load testing or static load testing. This standard is confined to test methods for loading a deep foundation element or elements from the top, in the downward direction. The loading requires structural elements be constructed that resist upward movement, often referred to collectively as a reaction system. The principal measurements taken in addition to load are displacements.

³ Available from American Society of Mechanical Engineers (ASME), ASME International Headquarters, Three Park Ave., New York, NY 10016-5990, <http://www.asme.org>.



4.2 This standard allows the following test procedures:

<u>Procedure A</u>	<u>Quick Test</u>	<u>9.1.2</u>
<u>Procedure B</u>	<u>Maintained Test (optional)</u>	<u>9.1.3</u>
<u>Procedure C</u>	<u>Constant Rate of Penetration Test (optional)</u>	<u>9.1.4</u>

5. Significance and Use

5.1 Field tests provide the most reliable relationship between the axial load applied to a deep foundation and the resulting axial movement. Test results may also provide information used to assess the distribution of side shear resistance along the pile shaft, element, the amount of end bearing developed at the pile element toe, and the long-term load-deflection behavior. ~~A foundation designer~~ The engineer may evaluate the test results to determine if, after applying an appropriate factor of safety, ~~the pile or pile group has an ultimate static capacity~~ appropriate factors, the element or group of elements has a static capacity, load response and a deflection at service load satisfactory to support a specific ~~the foundation.~~ When performed as part of a ~~multiple-pile~~ multiple-element test program, the ~~designer~~ engineer may also use the results to assess the viability of different piling types, sizes and types of foundation elements and the variability of the test site.

5.2 If feasible, and without exceeding the safe structural load on the pile(s) or pile cap, element or element cap (hereinafter unless otherwise indicated, “element” and “element group” are interchangeable as appropriate), the maximum load applied should reach a failure load from which the Engineer ~~engineer~~ may determine the ~~ultimate~~ axial static compressive load capacity of the pile(s) element. Tests that achieve a failure load may help the ~~designer~~ engineer improve the efficiency of the foundation design by reducing the piling foundation element length, quantity, or size.

5.3 If deemed impractical to apply axial test loads to an inclined pile, element, the Engineer ~~engineer~~ may elect to use axial test results from a nearby vertical pile element to evaluate the axial capacity of the inclined pile element. Or, the engineer may elect to use a bi-directional axial test on an inclined element (Test Methods D8169).

NOTE 1—The quality of the result produced by this test method is dependent on the competence of the personnel performing it, and the suitability of the equipment and facilities used. Agencies that meet the criteria of Practice D3740 are generally considered capable of competent and objective testing/sampling/ ~~inspection/~~ inspection/ and the like. Users of this test method are cautioned that compliance with Practice D3740 does not in itself assure reliable results. Reliable results depend on many factors; Practice D3740 provides a means of evaluating some of those factors.

ASTM D1143/D1143M-20

5.4 Different loading test procedures may result in different load-displacement curves. The Quick Test (10.1.2) and Constant Rate of Penetration Test (10.1.4) typically can be completed in a few hours. Both are simple in concept, loading the element relatively quickly as load is increased. The Maintained Test (10.1.3) loads the element in larger increments and for longer intervals which could cause the test duration to be significantly longer. Because of the larger load increments the determination of the failure load can be less precise, but the Maintained Test is thought to give more information on creep settlements (settlement due to consolidation is beyond the capability of the test procedures described in this standard). Although control of the Constant Rate of Penetration Test is somewhat more complicated (and uncommon for large diameter or capacity elements), the test may produce the smoothest curve and thus the best possible definition of capacity. The engineer must weigh the complexity of the procedure and other limitations against any perceived benefit of a smoother curve.

5.5 The scope of this standard does not include analysis for foundation capacity, but in order to analyze the test data appropriately it is important that information on factors that affect the derived mobilized axial static capacity are properly documented. These factors may include, but are not limited to the following:

5.5.1 Potential residual loads in the element which could influence the interpreted distribution of load at the element tip and along the element shaft.

5.5.2 Possible interaction of friction loads from test element with upward friction transferred to the soil from anchor elements obtaining part or all of their support in soil at levels above the tip level of the test element.

5.5.3 Changes in pore water pressure in the soil caused by element driving, construction fill, and other construction operations which may influence the test results for frictional support in relatively impervious soils such as clay and silt.

5.5.4 Differences between conditions at time of testing and after final construction such as changes in grade or groundwater level.

5.5.5 Potential loss of soil supporting the test element from such activities as excavation and scour.

5.5.6 Possible differences in the performance of an element in a group or of an element group from that of a single isolated element.

5.5.7 Effect on long-term element performance of factors such as creep, environmental effects on element material, negative friction loads not previously accounted for, and strength losses.

5.5.8 Type of structure to be supported, including sensitivity of structure to settlements and relation between live and dead loads.

5.5.9 Special testing procedures which may be required for the application of certain acceptance criteria or methods of interpretation.

5.5.10 Requirement that non-tested element(s) have essentially identical conditions to those for tested element(s) including, but not limited to, subsurface conditions, element type, length, size and stiffness, and element installation methods and equipment so that application or extrapolation of the test results to such other elements is valid.

6. Test Foundation Preparation

6.1 Excavate or add fill to the ground surface around the test pile or pile group element to the final design elevation unless otherwise approved by the Engineer/engineer.

6.2 Cut off or build up the test pile element as necessary to permit construction of the load-application apparatus, placement of the necessary testing and instrumentation equipment, and observation of the instrumentation. Remove any damaged or unsound material from the pile element top and prepare the surface so that it is perpendicular to the pile element axis with minimal irregularity to provide a good bearing surface for a test plate.

6.3 For tests of single piles/elements, install a solid steel test plate at least 25 mm [1 in.] thick perpendicular to the long axis of the test pile element that covers the complete pile element top area. The test plate shall span across and between any unbraced flanges on the test pile element. Thicker plates may be required for larger elements or imperfect or rough element tops.

6.4 For tests on pile element groups, cap the pile element group with steel-reinforced concrete or a steel load frame designed for the anticipated ~~loads~~ loads by the structural engineer. Provide a clear space beneath the pile element cap as specified by the Engineer/engineer to eliminate any bearing on the underlying ground surface. For each loading point on the pile element cap, provide a solid steel test plate oriented perpendicular to the axis of the pile element group with a minimum thickness of 25 mm [1 in.], as needed to safely apply load to the pile element cap. Center a single bearing plate on the centroid of the pile element group. Locate multiple bearing plates symmetrically about the centroid of the pile element group. Boxes and beams may bear directly on the pile element cap when designed to bear uniformly along their contact surface with the cap.

6.5 To minimize stress concentrations due to minor irregularities of the pile element top surface, set test plates bearing on the top of precast or cast-in-place concrete piles/elements in a thin layer of quick-setting, non-shrink grout, less than 6 mm [0.25 in.] thick and having a compressive strength greater than the test pile element at the time of the test. Set test plates, boxes, and beams designed to bear on a concrete pile element cap in a thin layer of quick-setting, non-shrink grout, less than 6 mm [0.25 in.] thick and having a compressive strength greater than the pile element cap at the time of the test. For tests on steel piles/elements, or a steel load frame, weld the test plate to the pile element or load frame. For tests on individual timber piles/elements, set the test plate directly on the cleanly cut top of the pile element, or in grout as described for concrete piles/elements.

NOTE 2—Deep foundations sometimes include hidden defects that may go unnoticed prior to the static testing. Low strain integrity tests as described in D5882 and ultrasonic crosshole integrity tests as described in D6760, and thermal integrity profiling as described in Test Methods D7949 may provide a useful pre-test evaluation of the test foundation.

NOTE 3—When testing a cast-in-place concrete element such as a drilled shaft, the size, shape, material composition and properties of the element can influence the element capacity and the interpretation of strain measurements described in Section 9.



7. Safety Requirements

7.1 All operations in connection with element load testing shall be carried out in such a manner so as to minimize, avoid, or eliminate the exposure of people to hazard. The following safety rules are in addition to general safety requirements applicable to construction operations:

7.1.1 Keep all test and adjacent work areas, walkways, platforms, and the like, clear of scrap, debris, small tools, and accumulations of snow, ice, mud, grease, oil, or other slippery substances.

7.1.2 Provide timbers, blocking and cribbing materials made of quality material and in good serviceable condition with flat surfaces and without rounded edges.

7.1.3 Hydraulic jacks shall be equipped with hemispherical bearings or shall be in complete and firm contact with the bearing surfaces and shall be aligned with axis of loading so as to avoid eccentric loading.

7.1.4 Loads shall not be hoisted, swung, or suspended over any person and shall be controlled by tag lines.

7.1.5 For tests on inclined elements, all inclined jacks, bearing plates, test beam(s), or frame members shall be firmly fixed into place or adequately blocked to prevent slippage upon release of load.

7.1.6 All reaction loads shall be stable and balanced. When using loading method in 8.4, safety wedges shall be in place at all times to prevent the platform from tipping. During testing, movements of the reaction load or system should be monitored to detect impending unstable conditions.

7.1.7 All test beams, reaction frames, platforms, and boxes shall be adequately supported at all times.

7.1.8 Only authorized personnel shall be permitted within the immediate test area, and only as necessary to monitor test equipment. The overall load test plan should include all provisions and systems necessary to minimize or eliminate the need for personnel within the immediate test area. All reasonable effort shall be made to locate pumps, load cell readouts, data loggers, and test monitoring equipment at a safe distance away from jacks, loaded beams, weighted boxes, dead weights, and their supports and connections.

8. Apparatus for Applying and Measuring Loads

8.1 General:

8.1.1 The apparatus for applying compressive loads to a test ~~pile or pile group~~ element shall conform to one of the methods described in ~~6.38.3–6.68.6~~. Unless otherwise specified by the Engineer, the apparatus for applying and measuring loads described in this section shall be ~~capable of safely applying at least 120 % of the maximum anticipated test load, designed in accordance with recognized standards by a qualified engineer who shall clearly define the maximum allowable load that can be safely applied.~~ Use the method described in ~~6.38.3~~ to apply axial loads to either vertical or inclined ~~piles or pile groups~~ elements. Use the methods described in ~~6.48.4–6.6~~ to apply only vertical loads.

8.1.2 Align the test load apparatus with the longitudinal axis of the ~~pile or pile group~~ element to minimize eccentric loading. When necessary to prevent lateral deflection and buckling along the unsupported ~~pile~~ element length, provide lateral braces that do not influence the axial movement of the ~~pile~~ element, or ~~pile~~ element cap.

8.1.3 Each jack shall include a hemispherical bearing or similar device to minimize lateral loading of the ~~pile~~ element or group. The hemispherical bearing should include a locking mechanism for safe handling and setup. Center bearing plates, hydraulic jack(s), load cell(s), and hemispherical bearings on the test beam(s), test ~~pile~~ element, or test ~~pile~~ element cap.

8.1.4 Provide bearing stiffeners as needed between the flanges of test and reaction beams. Provide steel bearing plates as needed to spread the load from the outer perimeter of the jack(s), or the bearing surface of beams or boxes, to bear on the surface of the test ~~pile~~ element or ~~pile~~ element cap. Also provide steel bearing plates to spread the load between the jack(s), load cells, and hemispherical bearings, and to spread the load to the test beam(s), test ~~pile~~ element, or ~~pile~~ element cap. Bearing plates shall extend the full flange width of steel beams and the complete top area of ~~piles~~ elements, or as specified by the ~~Engineer~~, structural engineer, so as to provide full bearing and distribution of the load.



8.1.5 Unless otherwise specified, provide steel bearing plates that have a total thickness adequate to spread the bearing load between the outer perimeters of loaded surfaces at a maximum angle of 45° to the loaded axis. For center hole jacks and center hole load cells, also provide steel plates adequate to spread the load from their inner diameter to their central axis at a maximum angle of 45° , or per manufacturer recommendations. Bearing plates shall extend the full width of the test beam(s) or any steel reaction members so as to provide full bearing and distribution of the load. These bearing plates are additive to plates described in Section 6.

8.1.6 A qualified engineer shall design and/or approve all aspects of the loading apparatus, including loaded members, support frames, reaction piles (if used), instruments and loading procedures. The test beam(s), load platforms, and support structures shall have sufficient size, strength, and stiffness to prevent excessive deflection and instability up to the maximum anticipated test load.

NOTE 4—Rotations and lateral displacements of the test ~~pile~~ pile or pile cap may occur during loading, especially for pile extending above the soil surface or through weak soils. Design and construct the support ~~reactions~~ reactions, loading apparatus and equipment to resist any undesirable or possibly dangerous rotations or lateral ~~displacements~~ displacements. Monitor these displacements during the test and immediately halt test if undesirable rotations or lateral displacements occur.

8.2 Hydraulic Jacks, Gages, Transducers, and Load Cells:

8.2.1 The hydraulic jack(s) and their operation shall conform to ASME B30.1 ~~Jacks~~ Jack(s) and load cell(s) shall have a nominal load capacity exceeding the maximum anticipated ~~jack~~ test load by at least 20 %. The jack, pump, and any hoses, pipes, fittings, gages, or transducers used to pressurize it shall be rated to a safe pressure corresponding to the nominal jack capacity.

8.2.2 The hydraulic ~~jack ram(s)~~ jack(s) shall have a ram (piston, rod) travel greater than the sum of the anticipated maximum axial movement of the ~~pile~~ element plus the deflection of the test beam and the elongation and movement of any anchoring system, but not less than ~~15 %~~ 15 % of the average ~~pile diameter or width.~~ element diameter or width (or any other specified and approved displacement requirement). Use a single high-capacity jack when possible. When using a multiple jack system, provide jacks of the same make, model, and capacity, and supply the jack pressure through a common manifold. Fit the manifold and each jack with a pressure gage to detect malfunctions and imbalances.

8.2.3 Unless otherwise specified, the hydraulic jack(s), pressure gage(s), and pressure transducer(s) shall ~~have a calibration~~ each be calibrated to at least the maximum anticipated jack load performed within the six months prior to each test or series of tests. Furnish the calibration report(s) prior to performing a test, which the test. Each report shall include the ambient temperature and individual calibrations shall be performed for multiple discrete ram strokes up to the maximum stroke of the jack.

8.2.4 Each complete jacking and pressure measurement system, including the hydraulic pump, should be calibrated as a unit when practicable. The hydraulic jack(s) shall be calibrated over the complete range of ram travel for increasing and decreasing applied loads. If two or more jacks are to be used to apply the test load, they shall be of the same make, model, and size, connected to a common manifold and pressure gage, and operated by a single hydraulic pump. The calibrated jacking system(s) shall have accuracy within 5 % of the maximum applied load. When not feasible to calibrate a jacking system as a unit, calibrate the jack, pressure gages, and pressure transducers separately, and each of these components shall have accuracy within 2 % of the applied load.

8.2.5 Pressure gages shall have minimum graduations less than or equal to 1 % of the maximum applied load and shall conform to ASME B40.100 Pressure ~~Gages~~ Gauges and Gauge Attachments with an accuracy grade 1A having a permissible error ± 1 % of the span. Pressure transducers shall have a minimum resolution less than or equal to 1 % of the maximum applied load and shall conform to ASME B40.100 with an accuracy grade 1A having a permissible error ± 1 % of the span. When used for control of the test, pressure transducers shall include a real-time display.

8.2.6 ~~If the maximum test load will exceed 900 kN [100 tons], place a properly constructed~~ Place a properly situated load cell or equivalent device in series with each hydraulic jack. Unless otherwise specified, the load cell(s) shall have a calibration to at least the maximum anticipated jack load performed within the six months prior to each test or series of tests. The calibrated load cell(s) or equivalent device(s) shall have accuracy within 1 % of the applied load, including an eccentric loading of up to 1 % applied at an eccentric distance of 25 mm [1 in.]. After calibration, load cells shall not be subjected to impact loads. A load cell is recommended, but not required, for lesser load. If not practicable to use a load cell, include embedded strain gages located in close proximity to the jack to confirm the applied load.

8.2.7 Do not leave the hydraulic jack pump unattended at any time during the test. Automated jacking systems shall include a clearly marked mechanical override to safely reduce hydraulic pressure in an emergency.

8.3 Load Applied by Hydraulic Jack(s) Acting Against Anchored Reaction Frame (See Fig. 1 and Fig. 2):

8.3.1 Apply the test load to the pile or pile group element with the hydraulic jack(s) reacting against the test beam(s) centered over the test pile, or pile group, element. Install a sufficient number of anchor piles-anchors or suitable anchoring device(s)devices to provide adequate reactive capacity for the test beam(s). Provide a clear distance from the test pile or pile group element of at least five times the maximum diameter of the largest anchor or test pile(s),element(s), but not less than 2.5 m [8 ft]. The Engineerengineer may increase or decrease this minimum clear distance based on factors such as the type and depth of reaction, soil conditions, and magnitude of loads so that reaction forces do not significantly effectaffect the test results.

NOTE 5—Excessive vibrations during anchor pileelement installation in non-cohesive soils may affect test results. Anchor pileslements that penetrate deeper than the test pileelement may affect test results. Install the anchor pileslements nearest the test pileelement first to help reduce installation effects.

8.3.2 Provide sufficient clearance between the bottom flange(s) of the test beam(s) and the top of the test pile or pile group element to place the necessary bearing plates, hydraulic jack(s), hemispherical bearing, and load cell(s). For test loads of high magnitude requiring several anchors, a steel framework may be required to transfer the applied loads from the test beam(s) to the anchors.

8.3.3 When testing individual inclined piles,elements, align the jack(s), test beam(s), and anchor pileslements with the inclined longitudinal axis of the test pile,element.

8.3.4 Attach the test beam(s) (or reaction framework if used) to the anchoring devices with connections designed to adequately transfer the applied loads to the anchors so as to prevent slippage, rupture or excessive elongation of the connections under maximum required test load.

8.4 Load Applied by Hydraulic Jack(s) Acting Against a Weighted Box or Platform (Kentledge Type) (Fig. 3):

8.4.1 This apparatus is typically used to test lightly loaded foundation elements. It is not common to test more heavily loaded elements due to practical and possible safety concerns.

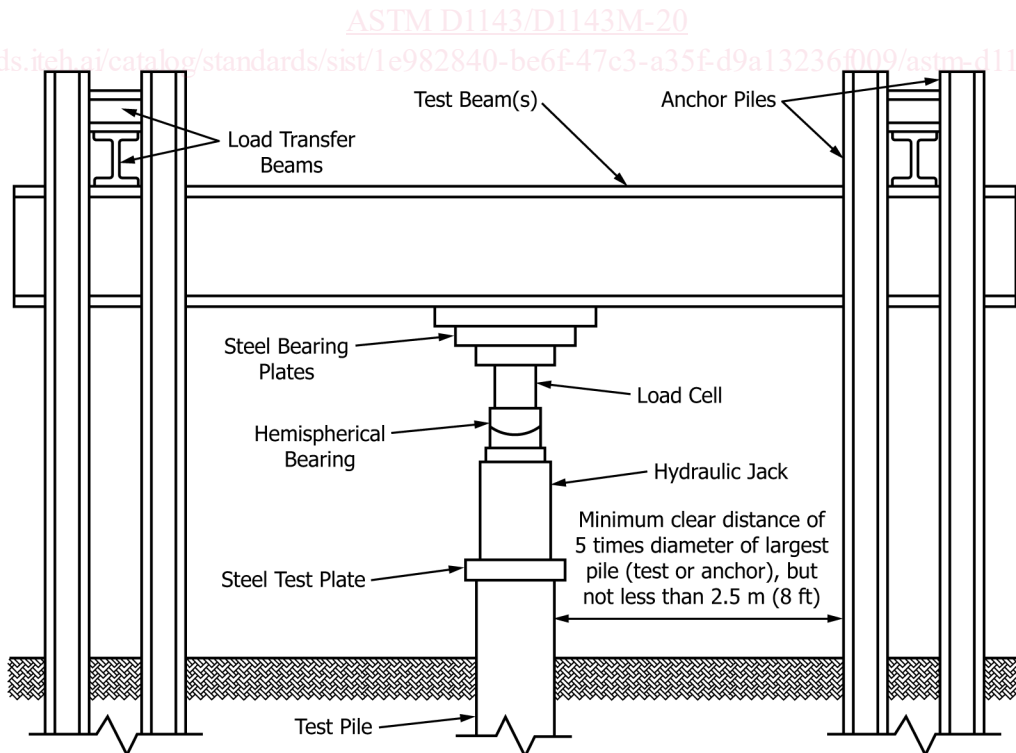

FIG. 1 Schematic of Hydraulic Jack Acting Against an Element Acting against Anchored Reaction Frame

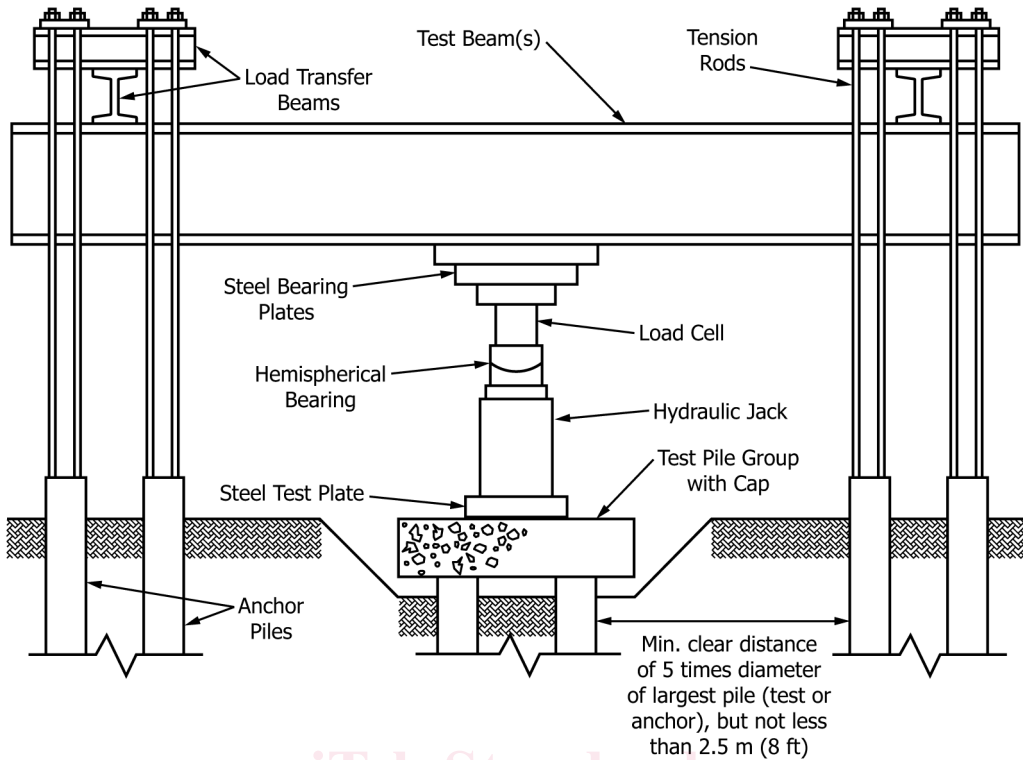

FIG. 2 Schematic of Hydraulic Jack on a Pile Element Group Acting Against an Anchored Reaction Frame

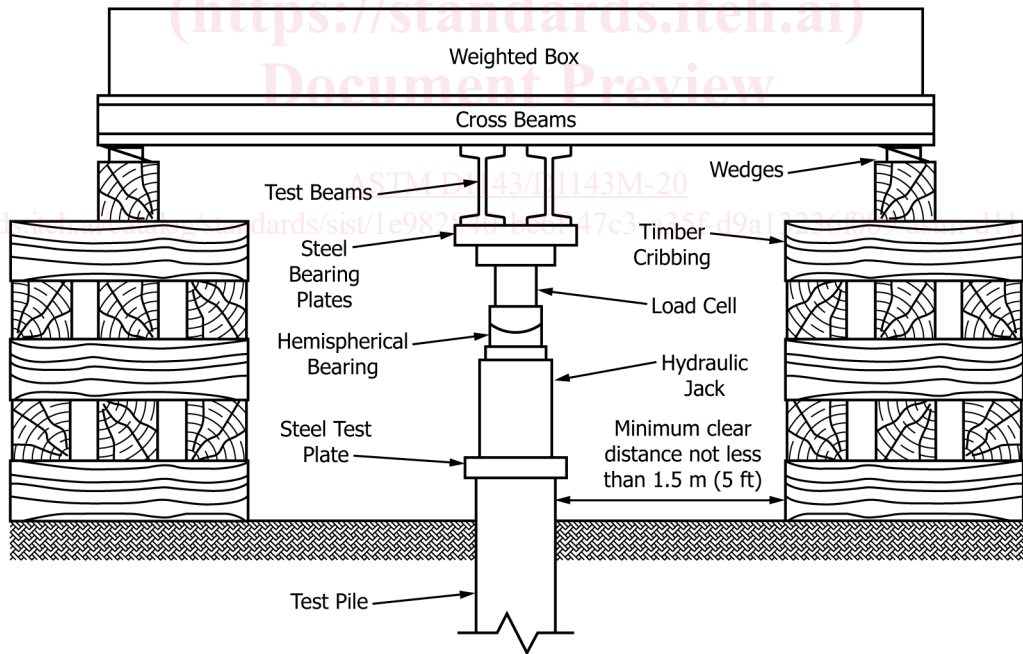

FIG. 3 Schematic Hydraulic Jack Acting Against on an Element Acting against a Weighted Box or Platform

8.4.2 Apply the test load to the pile or pile group element with the hydraulic jack(s) reacting against the test beam(s) centered over the test pile, or pile group element. Center a box or platform box, platform, or stackable weights (such as square concrete blocks) on the test beam(s) with the edges of the box or platform parallel to the test beam(s) supported by cribbing or pile elements placed as far from the test pile or pile group element as practicable, but in no case less than a clear distance of 1.5 m [5 ft]. If cribbing is used, the bearing area of the cribbing at ground surface shall be sufficient to prevent adverse settlement of the weighted box or platform.

8.4.3 The test beam(s) shall have sufficient size and strength to prevent excessive deflection under the maximum load, and sufficient clearance between the bottom flange(s) of the test beam(s) and the top of the test ~~pile or pile group~~ element to place the necessary bearing plates, hydraulic jack(s), hemispherical bearing, and load cell(s). Support the ends of the test beam(s) on temporary cribbing or other devices.

8.4.4 Load the box or platform with any suitable material such as soil, rock, concrete, steel, or water-filled tanks with a total weight (including that of the test beam(s) and the box or platform) at least 10 % greater than the maximum anticipated test load. A suitable material must also be sufficiently uniform so that the weight distribution throughout the box is either uniform or at least centered.

8.5 *Load Applied Directly Using Known Weights (See ~~Fig. 43~~, ~~Fig. 5~~, and ~~Fig. 64~~):*

8.5.1 Center on the test ~~pile~~ element or ~~pile~~ element cap a test beam(s) of known weight and of sufficient size and strength to avoid excessive deflection under load with the ends supported on temporary cribbing (wedges) if necessary to stabilize the beam(s). Alternatively, the known test weights or loading material may be applied directly on the ~~pile~~ element or ~~pile~~ element cap.

8.5.2 Center and balance a platform of known weight on the test beam(s) or directly on the ~~pile~~ element cap with overhanging edges of the platform parallel to the test beam(s) supported by cribbing or by ~~pile~~ elements capped with timber beams, so that a clear distance of not less than 1.5 m [5 ft] is maintained between the supports and the test ~~pile or pile group~~ element.

8.5.3 Place sufficient pairs of timber wedges between the top of the cribbing or timber cap beams and the bottom edges of the platform so that the platform can be stabilized during loading or unloading.

8.5.4 Apply the test loads to the ~~pile or pile group~~ element using known weights. When loading the platform, remove any temporary supports at the ends of the test beam(s) and tighten the wedges along the bottom edges of the platform so that the platform is ~~stable~~ stable, but not so that an undue fraction of the total load is transferred to the ~~wedges~~. Use loading materials such as steel or concrete so that the weight of incremental loads can be determined with accuracy of at least 5 %.

NOTE 6—The method described in 8.5 may not be appropriate for higher capacity elements. Depending on the magnitude of the applied load and axial movement, platform stability may be difficult to control at or near a failure load when applying the load directly. The user should consider using a different load method when anticipating ~~a failure load~~ that a failure load will be applied and when larger elements are tested.

NOTE 7—The loading apparatus described in ~~6.58.5~~ may allow target rod level readings directly on the center of the ~~pile~~ element top or ~~pile~~ element cap to measure the ~~pile~~ element top movement described in ~~7.2.49.2.4~~. To accommodate the target rod, use a double test beam with sufficient space between the beams, leave a hole through the platform, and leave a line of sight between the test weights for survey level readings.

8.6 *Other Types of Loading Apparatus (Optional)*—The ~~Engineer~~ engineer may specify another type of loading apparatus satisfying the basic requirements of ~~6.38.3~~ or ~~to 6.48.5~~.

9. Apparatus for Measuring Movement and Strain

9.1 *General:*

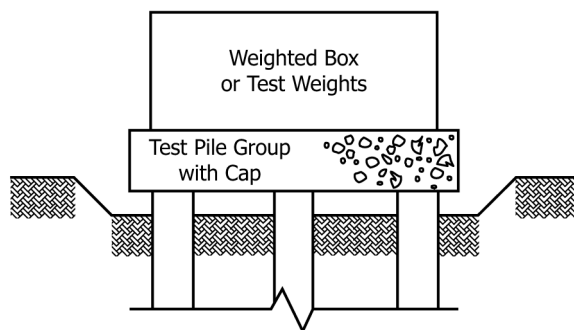

FIG. 4 Schematic of Direct Loading on a Single Pile Using Weighted Platform Element Group

FIG. 5 Schematic of Direct loading on a Pile Group Using a Weighted Platform

FIG. 6 Schematic of Direct Loading on a Pile Group



9.1.1 Reference beams and wirelines shall be supported independent of the loading system, with supports firmly embedded in the ground at a clear distance from the test ~~pile~~element of at least five times the diameter of the test ~~pile(s)~~element, but not less than 2.5 m [8 ft], and at a clear distance from any anchor ~~piles~~element, and at least five times the diameter of the anchor ~~pile(s)~~element, but not less than 2.5 m [8 ft] ~~clear distance from any anchor element~~. Reference supports shall also be located as far as practicable from any cribbing ~~supports~~supports, not less than a clear distance of 2.5 m [8 ft]. The clear distance between the test element and reference supports may be decreased to no less than three diameters under certain circumstance, if, the engineer understands the possible negative effects and if, the reference beam or wireline supports are monitored at least periodically during the test.

9.1.2 Reference beams ~~shall~~may be monolithic, such as a wide flange section, or composed of many materials, such as wood in the form of a wood truss. However, any reference beam shall be designed to minimize vertical movement of its center during the test due to heat or moisture (humidity changes or periodic rain). Reference beams shall have adequate strength, stiffness, and cross bracing to support the test instrumentation and minimize vibrations and movement that may degrade measurement of the ~~pile~~element movement. One end of each beam shall be free to move laterally as the beam length changes with temperature variations. Supports for reference beams and wirelines shall be isolated from moving water and wave action. Provide a tarp or shelter to prevent direct sunlight and precipitation from affecting the measuring systems and reference systems. In order to verify beam stability, monitor the gages affixed to the beam for an appropriate period of time prior to loading. To avoid delay, begin this monitoring as soon as practical prior to setting up other testing components. Make adjustments as needed.

9.1.3 Dial and electronic displacement indicators shall conform to ASME B89.1.10.M ~~and B89.1.10.M~~. Indicators used to measure top of element displacement should generally have a travel of ~~±0.150 mm~~ [4[6 in.], but shall have a minimum travel of at least 50 mm [2 in.]. Indicators used to measure element compression (see 9.4) shall have a travel of at least 25 mm [1 in.]. Provide greater travel, longer stems, or sufficient calibrated blocks to allow for greater travel if anticipated. Electronic—All of the electronic indicators shall have a real-time display of the movement available during the test—test whether directly on each indicator or collectively through a data logger or multiplexor output or computer. Provide a smooth bearing surface for the indicator stem perpendicular to the direction of stem travel, such as a small, lubricated, glass plate glued in place. Except as required in Indicators used to measure 7.4, indicators top of element displacement shall have minimum graduations of 0.25 mm [0.01 in.] or less, with similar accuracy. Scales used to measure pile movements shall have a length no less than 150 mm [6 in.]. Survey rods shall have minimum graduations of 0.51 mm [0.02 in.][0.01 ft] or less, with similar accuracy, and shall be read to the nearest 0.1 mm [0.005 in.]. Survey rods [0.001 ft]. Displacement indicators used for measuring element compression (see 9.4) shall have a travel of at least 25 mm [1 in.] and minimum graduations of ±0.01 mm [0.01 ft][0.0005 in.] or less, with similar accuracy—accuracy or better, and shall be read to the nearest 0.1 mm [0.001 ft]—graduation or less.

9.1.4 Dial indicators and electronic displacement indicators shall be in good working condition and shall have a full range calibration within ~~three years~~one year prior to each test or series of tests. Furnish calibration reports prior to performing a test, including the ambient air temperature during ~~calibration~~calibration.

9.1.5 Clearly identify each displacement indicator, scale, and reference point used during the test with a reference number or letter.

9.1.6 Indicators, scales, or reference points attached to the test ~~pile~~pile, ~~pile~~element, ~~element~~element cap, reference beam, or other references shall be firmly affixed to prevent movement relative to the test ~~pile~~element or ~~pile~~element cap during the test. Unless otherwise approved by the ~~Engineer~~engineer, verify that reference beam and wireline supports do not move during the test by using a surveyor's level to take readings on a survey rod or a scale with reference to a permanent ~~bench mark~~benchmark located outside of the immediate test ~~area~~area, for example, in excess of ten times the largest cross-sectional dimension of the foundation element, as practical.

9.2 *Pile-Top of Element Axial Movements (See(see Fig. 75):*

9.2.1 Unless otherwise specified, all axial compressive load tests shall include apparatus for measuring the axial movement of the test ~~pile~~element top, or ~~pile~~elements within a group, or the ~~pile~~group cap. This apparatus shall include a primary measurement system and at least one redundant, secondary system, using at least two of the systems described herein. If loading elements within a test group, either with a minimal cap or no cap, it may be necessary to measure some or all individual element tops.

NOTE 8—When possible use displacement indicators as the primary system to obtain the most precise measurements. Use the redundant system(s) to check top movement data and provide continuity when the measuring system is disturbed or reset for additional movement.

NOTE 9—PileElement top movements measured directly on the test ~~pile~~element have superior accuracy to measurements on the test plate, but with