



**SLOVENSKI STANDARD**  
**SIST ISO 4753:1996**

**01-april-1996**

---

**Mehanski vezni elementi - Izteki navojev za metrske navoje ISO**

Fasteners -- Ends of parts with external metric ISO thread

Éléments de fixation -- Extrémités des éléments à filetage extérieur métrique ISO

**Ta slovenski standard je istoveten z: ISO 4753:1983**

[SIST ISO 4753:1996](https://standards.iteh.ai/catalog/standards/sist/e2a0178e-dba4-400f-808c-ac17590c76f8/sist-iso-4753-1996)

<https://standards.iteh.ai/catalog/standards/sist/e2a0178e-dba4-400f-808c-ac17590c76f8/sist-iso-4753-1996>

**ICS:**

21.040.10	Metrski navoji	Metric screw threads
21.060.01	Vezni elementi na splošno	Fasteners in general

**SIST ISO 4753:1996**

**en**

**iTeh STANDARD PREVIEW**  
**(standards.iteh.ai)**

SIST ISO 4753:1996

<https://standards.iteh.ai/catalog/standards/sist/e2a0178e-dba4-400f-808c-ac17590c76f8/sist-iso-4753-1996>

---

# International Standard



# 4753

---

INTERNATIONAL ORGANIZATION FOR STANDARDIZATION • МЕЖДУНАРОДНАЯ ОРГАНИЗАЦИЯ ПО СТАНДАРТИЗАЦИИ • ORGANISATION INTERNATIONALE DE NORMALISATION

---

## Fasteners — Ends of parts with external metric ISO thread

*Éléments de fixation — Extrémités des éléments à filetage extérieur métrique ISO*

First edition — 1983-05-01

ISO 4753:1996  
SIST ISO 4753:1996  
https://standards.iteh.ai/catalog/standards/sist/e2a0178e-dba4-400f-808c-ac17590c76f8/sist/iso-4753-1996

ITEH STANDARD PREVIEW  
(standards.iteh.ai)

---

UDC 621.882.092

Ref. No. ISO 4753-1983 (E)

Descriptors : fasteners, bolts, screws, dimensions.

## Foreword

ISO (the International Organization for Standardization) is a worldwide federation of national standards bodies (ISO member bodies). The work of developing International Standards is carried out through ISO technical committees. Every member body interested in a subject for which a technical committee has been authorized has the right to be represented on that committee. International organizations, governmental and non-governmental, in liaison with ISO, also take part in the work.

Draft International Standards adopted by the technical committees are circulated to the member bodies for approval before their acceptance as International Standards by the ISO Council.

International Standard ISO 4753 was developed by Technical Committee ISO/TC 2, *Fasteners*, and was circulated to the member bodies in December 1981.

It has been approved by the member bodies of the following countries:

Australia	Germany, F.R.	Norway
Austria	Hungary	Poland
Belgium	India	Romania
Brazil	Ireland	South Africa, Rep. of
Canada	Italy	Spain
China	Japan	Sweden
Czechoslovakia	Korea, Dem. P. Rep. of	Switzerland
Denmark	Korea, Rep. of	United Kingdom
Egypt, Arab Rep. of	Mexico	USSR
Finland	Netherlands	
France	New Zealand	

The member body of the following country expressed disapproval of the document on technical grounds:

USA

ITeH STANDARD PREVIEW  
(standards.iteh.ai)

SIST ISO 4753:1996

<https://standards.iteh.ai/catalog/standards/sist/e2a0178e-dba4-400f-808c-ac17590c76f8/sist-iso-4753-1996>

# Fasteners — Ends of parts with external metric ISO thread

## 1 Scope and field of application

This International Standard lays down the form and dimensions of ends of parts with external metric ISO thread (for example, bolt and screw ends) recommended for use, unless otherwise specified in the appropriate product standard.

## 2 Reference

ISO 225, *Fasteners — Bolts, screws, studs and nuts — Symbols and designations of dimensions.*

3 Dimensions

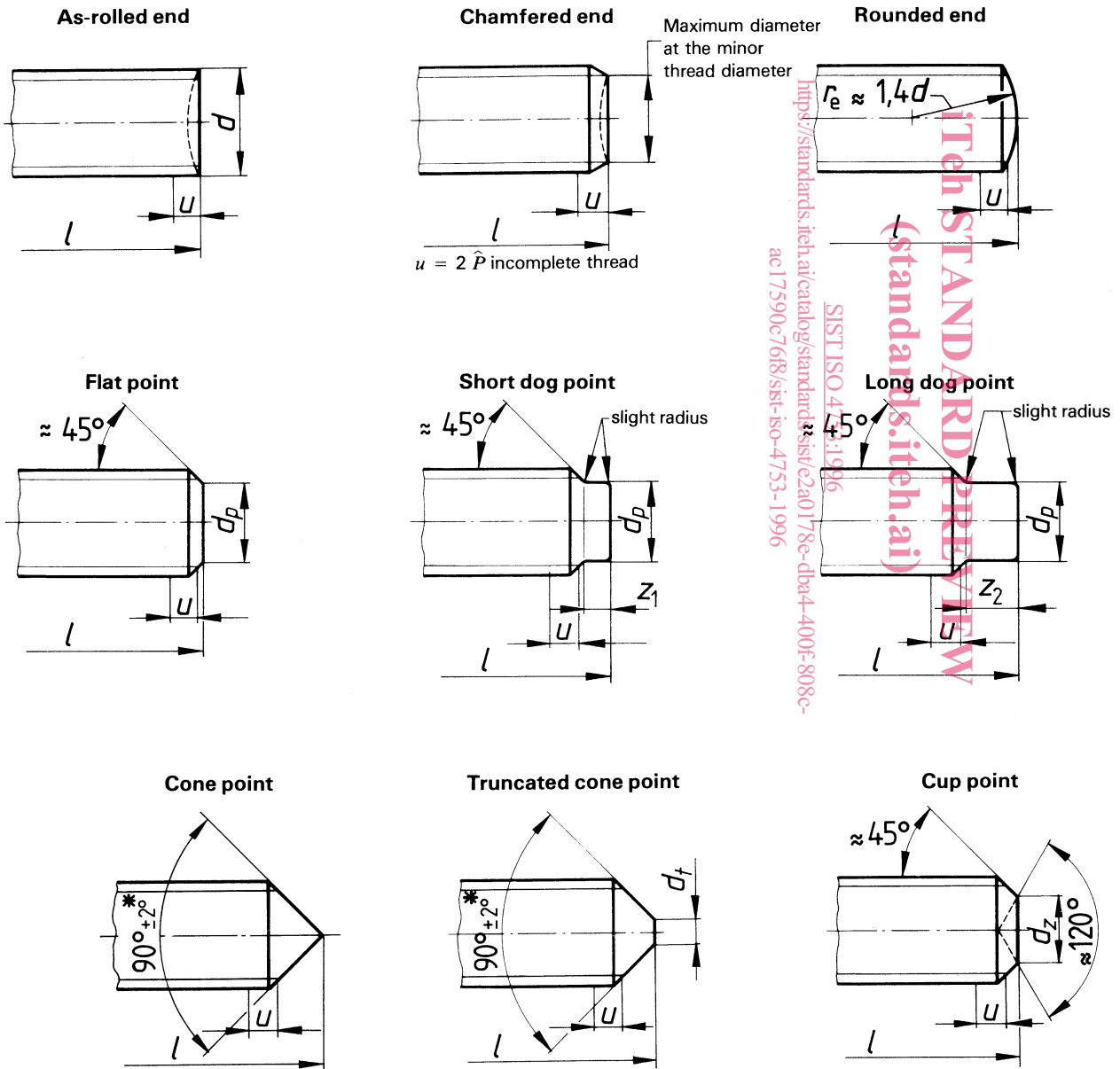

\*  $120^\circ \pm 2^\circ$  for short length screws; see product standard, e.g. ISO 4027

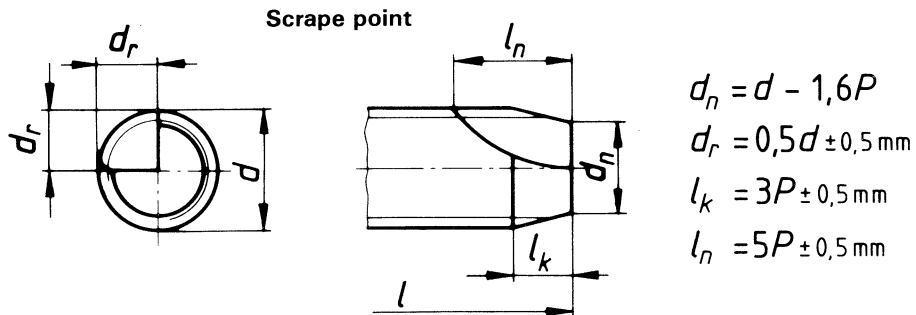

NOTES

- 1 The  $45^\circ$  angle applies only to the portion of the point below the root diameter of the thread.
- 2 Other proprietary scrape forms are permissible.

Table

Dimensions in millimetres

Thread diameter $d$	$d_p$ h14	$d_l^{1)}$ h16	$d_z$ h14	$z_1$ +IT14 0	$z_2$ +IT14 0
1	0,5	0,1	—	—	—
1,2	0,6	0,12	—	—	—
1,4	0,7	0,14	0,7	0,35	0,7
1,6	0,8	0,16	0,8	0,4	0,8
1,8	0,9	0,18	0,9	0,45	0,9
2	1	0,2	1	0,5	1
2,2	1,2	0,22	1,1	0,55	1,1
2,5	1,5	0,25	1,2	0,63	1,25
3	2	0,3	1,4	0,75	1,5
3,5	2,2	0,35	1,7	0,88	1,75
4	2,5	0,4	2	1	2
4,5	3	0,45	2,2	1,12	2,25
5	3,5	0,5	2,5	1,25	2,5
6	4	1,5	3	1,5	3
7	5	2	4	1,75	3,5
8	5,5	2	5	2	4
10	7	2,5	6	2,5	5
12	8,5	3	7	3	6
14	10	4	8,5	3,5	7
16	12	4	10	4	8
18	13	5	11	4,5	9
20	15	5	13	5	10
22	17	6	15	5,5	11
24	18	6	16	6	12
27	21	8	—	6,7	13,5
30	23	8	—	7,5	15
33	26	10	—	8,2	16,5
36	28	10	—	9	18
39	30	12	—	9,7	19,5
42	32	12	—	10,5	21
45	35	14	—	11,2	22,5
48	38	14	—	12	24
52	42	16	—	13	26

1) &lt; M5 no flat part on the cone required; the point may be slightly rounded.