



Designation: D6997 – 12 (Reapproved 2020)

# Standard Test Method for Distillation of Emulsified Asphalt<sup>1</sup>

This standard is issued under the fixed designation D6997; the number immediately following the designation indicates the year of original adoption or, in the case of revision, the year of last revision. A number in parentheses indicates the year of last reapproval. A superscript epsilon ( $\epsilon$ ) indicates an editorial change since the last revision or reapproval.

## 1. Scope

1.1 This test method covers the quantitative determination of residue and oil distillate in emulsified asphalts composed principally of a semisolid or liquid asphaltic base, water, and an emulsifying agent.

1.2 The values stated in SI units are to be regarded as the standard. No other units of measurement are included in this standard.

1.3 *This standard does not purport to address all of the safety concerns, if any, associated with its use. It is the responsibility of the user of this standard to establish appropriate safety, health, and environmental practices and determine the applicability of regulatory limitations prior to use.*

1.4 *This international standard was developed in accordance with internationally recognized principles on standardization established in the Decision on Principles for the Development of International Standards, Guides and Recommendations issued by the World Trade Organization Technical Barriers to Trade (TBT) Committee.*

## 2. Referenced Documents

2.1 *ASTM Standards:*<sup>2</sup>

- D7403 Test Method for Determination of Residue of Emulsified Asphalt by Low Temperature Vacuum Distillation
- D7497 Practice for Recovering Residue from Emulsified Asphalt Using Low Temperature Evaporative Technique
- E1 Specification for ASTM Liquid-in-Glass Thermometers
- E11 Specification for Woven Wire Test Sieve Cloth and Test Sieves

## 3. Summary of Method

3.1 A sample of emulsified asphalt is heated in an aluminum-alloy still to  $260 \pm 5^\circ\text{C}$  and the volumes of

<sup>1</sup> This test method is under the jurisdiction of ASTM Committee D04 on Road and Paving Materials and is the direct responsibility of Subcommittee D04.42 on Emulsified Asphalt Test.

Current edition approved Oct. 15, 2020. Published October 2020. Originally approved in 2004. Last previous edition approved in 2012 as D6997 – 12. DOI: 10.1520/D6997-12R20.

<sup>2</sup> For referenced ASTM standards, visit the ASTM website, www.astm.org, or contact ASTM Customer Service at service@astm.org. For *Annual Book of ASTM Standards* volume information, refer to the standard's Document Summary page on the ASTM website.

distillate and water obtained are measured. The residue from the distillation, and also any oil portion of the distillate, may be tested as required.

## 4. Significance and Use

4.1 This test method can be used for quantitative determination of residue and oil distillates in emulsified asphalts for specification acceptance, service evaluation, control, and research. This test method can also be used to obtain residue and oil distillate for further testing. This method may not be appropriate for emulsified asphalts containing latex or polymer; however, some specifying agencies may utilize this method and stipulate a lowered distillation temperature. By stipulating a lowered distillation temperature, the precision and bias statement may not be considered valid. Low-temperature methods such as Test Method D7403 and Practice D7497 are options for obtaining residue for latex or polymer modified emulsified asphalts.

## 5. Apparatus

5.1 *Aluminum-Alloy Still*—Approximately 241 mm in height by 95 mm inside diameter with cover and clamp as shown in Fig. 1. The dimensions as noted in Fig. 1 are provided as reference for the ease of the user and are considered noncritical dimensions.

NOTE 1—Residue by distillation results obtained with iron stills are acceptable.

5.2 *Gasket*—A variety of gasket materials may be used to seal the still providing they withstand the maximum temperature reached during distillation.

NOTE 2—Use of a gasket is optional if the joint can be ground to a tight fit or only residue recovery is required and further analysis on the water or oil distillate is not needed.

5.3 *Heat Sources*—Having holes on the inner periphery and having three spacers, to ensure centering of burner around the still (see Fig. 2). The dimensions as noted in Fig. 2 are provided for reference for the ease of the user and are considered noncritical dimensions.

NOTE 3—Optional use of a bunsen burner (equipped with optional wing tip) as shown in Fig. 3.

5.4 *Connection Apparatus*—Consisting of approximately 12 mm glass or metal connecting tube, tin shield (as detailed in Fig. 3), and a water-cooled glass condenser tube with a metal

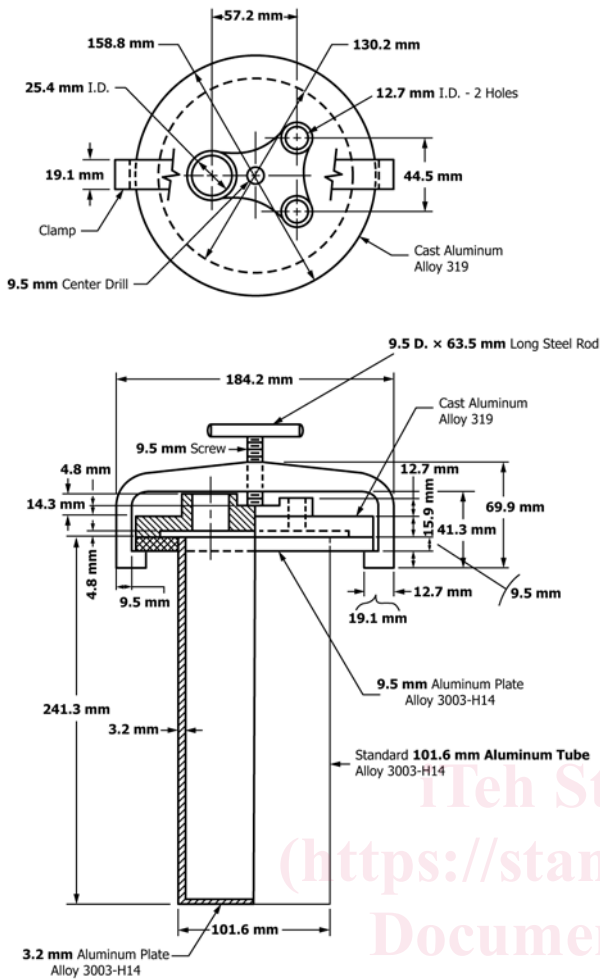

FIG. 1 Aluminum-Alloy Still

NOTE 4—For details of the assembly of apparatus for the distillation test, see Fig. 3.

## 6. Sample Conditioning for Testing

6.1 All emulsified asphalts shall be properly stirred to achieve homogeneity before testing.

6.2 All emulsified asphalts with viscosity testing requirements of 50 °C shall be heated to 50 ± 3 °C in the original sample container in a water bath or oven. The container should be vented to relieve pressure. After the sample reaches 50 ± 3 °C, stir the sample to achieve homogeneity.

6.3 Emulsified asphalts with viscosity testing requirements of 25 °C shall be conditioned to 25 ± 3 °C in the original sample container to achieve homogeneity. After the sample reaches 25 ± 3 °C, stir the sample to achieve homogeneity.

NOTE 5—Emulsified asphalts with viscosity testing requirements of 25 °C may be heated and stirred as specified in 6.2, if necessary.

6.4 Emulsified asphalts presented for testing from a storage tank may be tested at the storage tank temperature. Conditioning as in 6.2 and 6.3 is not required.

## 7. Procedure

7.1 Determine the mass of the aluminum-alloy still. Include in this determination the still, cover, clamp, temperature measuring device(s), small stopper (if used), and gasket (if used).

7.2 Add 200 ± 1.0 g of a representative sample of the emulsified asphalt. Record this mass.

NOTE 6—If additional residue is needed for further testing, the sample size may be increased. A total sample mass between 200 to 300 g will be considered acceptable. This mass must be recorded and used in calculations 8.1 and 8.2. The precision data of this method was developed using 200 g samples and may not apply to other sample sizes.

7.3 Securely clamp the cover on the still. If a gasket is used, insert between the still and the cover prior to clamping.

7.4 Insert the temperature measuring device first through a cork or silicone stopper, and then in one of the small holes provided in the cover. Seal the other hole with a cork or silicone stopper. Adjust the temperature measuring device so that the end of the probe or bulb is approximately 6 mm from the bottom of the still.

NOTE 7—A second temperature measuring device may be used in the second small hole, with the probe or bulb placed approximately 165 mm from the bottom of the still. A sudden change in temperature reading of upper temperature measuring device indicates foaming. Remove heat until foaming ceases.

7.5 Place the ring burner around the still approximately 150 mm from the bottom of the still. Apply heat by lighting this burner and adjusting to low flame. Also apply just enough heat from bunsen burner to the connecting tube to prevent condensation of water in this tube.

NOTE 8—Use of the bunsen burner is optional.

7.6 When the temperature reaches approximately 215 °C, move the ring burner approximately level with the bottom of the still. Increase the temperature to 260 ± 5 °C, maintaining it at this temperature for 15 min. Complete the total distillation in 60 ± 15 min from the first application of heat.

or borosilicate glass jacket. The metal connecting tube may be secured to the lid by a threaded compressing fitting. Glass connecting tube may be secured to the lid by means of a cork or silicone stopper. Other condensers of approximately 12 mm glass or metal tubing may be used, providing that the wetted length is 400 to 550 mm. The dimensions as noted in Fig. 3 are provided for reference for the ease of the user and are considered noncritical dimensions.

5.5 *Graduated Cylinder*—100 mL, with graduation intervals of 1.0 mL.

5.6 *Thermometer*—ASTM 7C thermometer, as prescribed in Specification E1, or any other thermometric device of equal accuracy.

5.7 *Balance*—Capable of weighing 3500 g to within ±0.1 g.

5.8 *Stoppers*—Cork (wrapped in foil) or silicone stoppers to seal holes in still cover, maintain temperature measuring device position, and secure connecting tube to still cover.

5.9 *Rubber Tubing*—Heat-resistant tubing of adequate size to secure glass to glass joint of connecting tube and condenser.

5.10 *Sieve*—300 μm sieve to capture foreign materials when suspected.

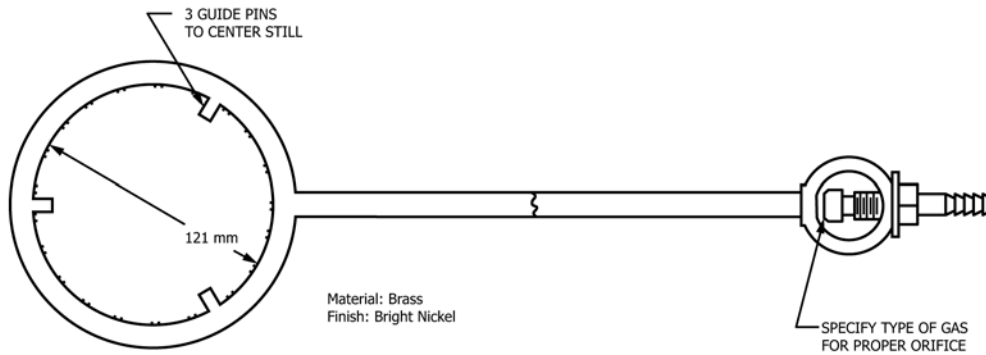

FIG. 2 Ring Burner with 125-mm Inside Diameter

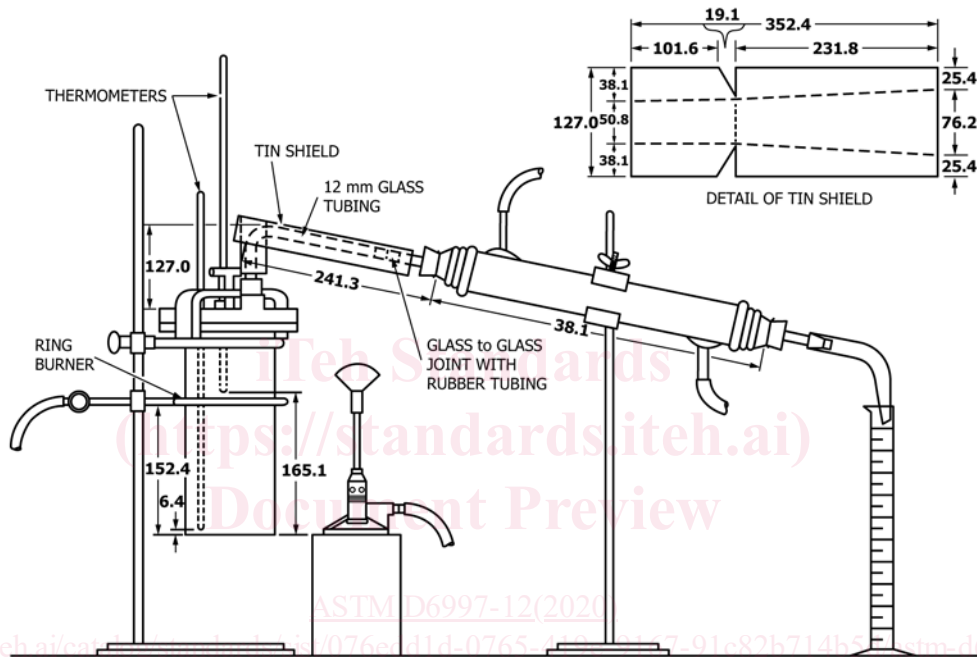

FIG. 3 Apparatus Assembly for Distillation Test of Emulsified Asphalts

NOTE 9—The ring burner may be raised to decrease chance of foam-over or lowered to the middle of still for emulsified asphalts containing no solvent. The ring burner may be gradually lowered as the distillation proceeds to ensure that the time requirements of this test method are satisfied. It is also acceptable to incorporate two ring burners rather than moving a single ring burner. If a secondary ring burner is used, only one ring burner is to be operational at any given point during the distillation.

7.7 Immediately at the expiration of the heating period, turn off the flame and again weigh the still and accessories as described in 7.1. The aluminum-alloy still at ambient temperature (7.1) weighs 1.5 g more than at 260 °C. Correct for this error by adding 1.5 g to gross weight obtained prior to calculating the percentage of residue by distillation. Calculate per 8.1 and report the percentage residue by distillation. Record the volume of oil distillate to the nearest 0.5 mL. Calculate per 8.2 and report the oil distillate as a volume percentage of the total emulsified asphalt based upon the sample weight as recorded in 7.2.

7.8 Stir the still contents by gently agitating the residue. This may be done using a swirling motion or stirring with a long glass or steel rod to obtain consistent material prior to pouring. Remove the cover from the still and immediately pour suitable portions of the residue into a container or molds required for residue testing. If there is foreign matter suspected in the residue, pour the material through a sieve prior to pouring into the test molds and container(s).

## 8. Calculation

8.1 Calculate the percentage of residue in the sample as follows:

$$\text{Sample residue, \%} = ((B - A)/C) \times 100 \quad (1)$$

where:

A = mass of empty still (7.1) assembly before test, g,