



Designation: D852 – 20

## Standard Test Method for Solidification Point of Benzene<sup>1</sup>

This standard is issued under the fixed designation D852; the number immediately following the designation indicates the year of original adoption or, in the case of revision, the year of last revision. A number in parentheses indicates the year of last reapproval. A superscript epsilon ( $\epsilon$ ) indicates an editorial change since the last revision or reapproval.

### 1. Scope\*

1.1 This test method covers the determination of the solidification point of benzene.

1.2 The following applies for the purposes of determining the conformance of the test results using this test method to applicable specifications, results shall be rounded off in accordance with the rounding-off method of Practice E29.

1.3 The values stated in SI units are to be regarded as standard. No other units of measurement are included in this standard.

1.4 **Warning**—Mercury has been designated by many regulatory agencies as a hazardous substance that can cause serious medical issues. Mercury, or its vapor, has been demonstrated to be hazardous to health and corrosive to materials. Caution should be taken when handling mercury and mercury containing products. See the applicable product Safety Data Sheet (SDS) for additional information. Users should be aware that selling mercury and/or mercury containing products into your state or country may be prohibited by law.

1.5 This standard does not purport to address all of the safety concerns, if any, associated with its use. It is the responsibility of the user of this standard to establish appropriate safety, health, and environmental practices and determine the applicability of regulatory limitations prior to use. For specific hazard statements, see Section 7.

1.6 This international standard was developed in accordance with internationally recognized principles on standardization established in the Decision on Principles for the Development of International Standards, Guides and Recommendations issued by the World Trade Organization Technical Barriers to Trade (TBT) Committee.

<sup>1</sup> This test method is under the jurisdiction of ASTM Committee D16 on Aromatic, Industrial, Specialty and Related Chemicals and is the direct responsibility of Subcommittee D16.01 on Benzene, Toluene, Xylenes, Cyclohexane and Their Derivatives.

Current edition approved Oct. 1, 2020. Published October 2020. Originally approved in 1945. Last previous edition approved in 2016 as D852 – 16. DOI: 10.1520/D0852-20.

### 2. Referenced Documents

#### 2.1 ASTM Standards:<sup>2</sup>

D1015 Test Method for Freezing Points of High-Purity Hydrocarbons (Withdrawn 2019)<sup>3</sup>

D1016 Test Method for Purity of Hydrocarbons from Freezing Points (Withdrawn 2019)<sup>3</sup>

D1193 Specification for Reagent Water

D3437 Practice for Sampling and Handling Liquid Cyclic Products

D6809 Guide for Quality Control and Quality Assurance Procedures for Aromatic Hydrocarbons and Related Materials

E1 Specification for ASTM Liquid-in-Glass Thermometers

E29 Practice for Using Significant Digits in Test Data to Determine Conformance with Specifications

E691 Practice for Conducting an Interlaboratory Study to Determine the Precision of a Test Method

#### 2.2 Other Document:

OSHA Regulations, 29 CFR paragraphs 1910.1000 and 1910.1200<sup>4</sup>

### 3. Terminology

#### 3.1 Definitions:

3.1.1 *solidification point, n*—an empirical constant defined as the temperature at which the liquid phase of a substance is in approximate equilibrium with a relatively small portion of the solid phase.

3.1.1.1 *Discussion*—Solidification point is distinguished from freezing point which is described in Test Method D1015. An interpretation of mol percent purity in terms of freezing point is given in Test Method D1016.

<sup>2</sup> For referenced ASTM standards, visit the ASTM website, www.astm.org, or contact ASTM Customer Service at service@astm.org. For Annual Book of ASTM Standards volume information, refer to the standard's Document Summary page on the ASTM website.

<sup>3</sup> The last approved version of this historical standard is referenced on www.astm.org.

<sup>4</sup> Available from U.S. Government Printing Office Superintendent of Documents, 732 N. Capitol St., NW, Mail Stop: SDE, Washington, DC 20401, http://www.access.gpo.gov.

\*A Summary of Changes section appears at the end of this standard

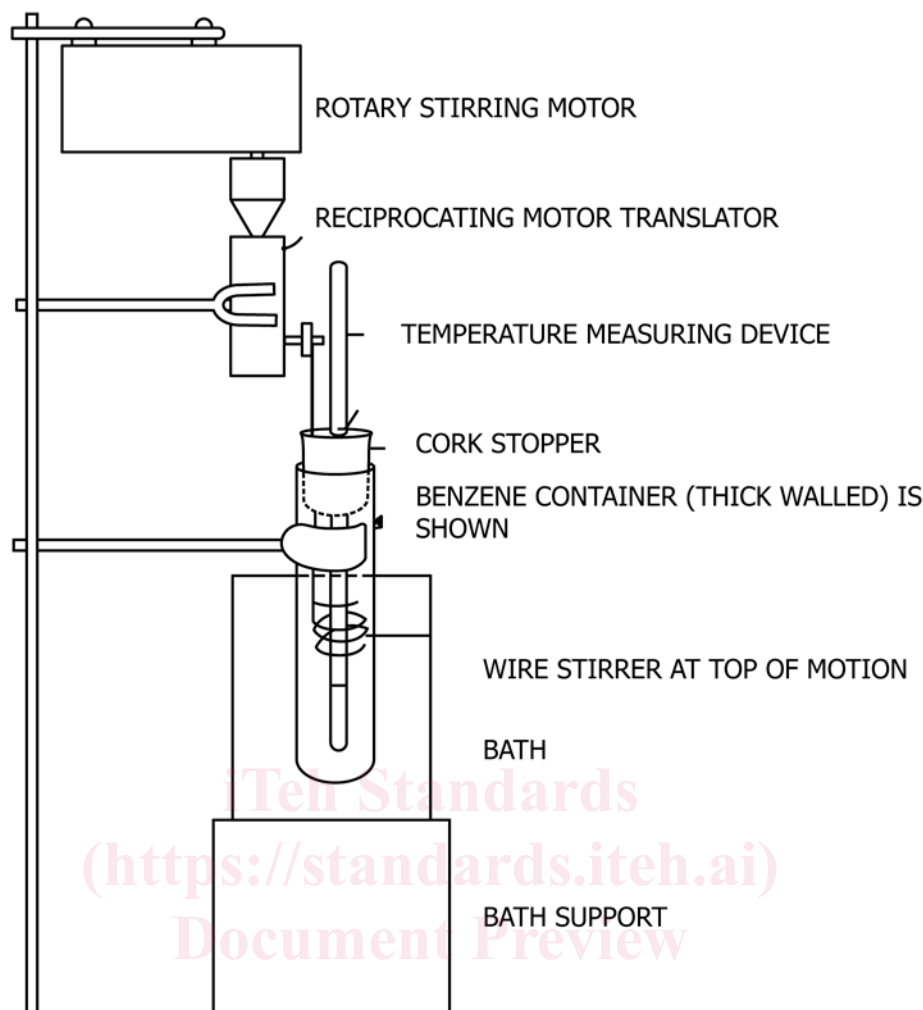

FIG. 1 Benzene Solidification Point Apparatus Set Up

<https://standards.iteh.ai/catalog/standards/sist/3f6d6f39-99b1-4a84-9f95-91d0235d2099/astm-d852-20>

#### 4. Summary of Test Method

4.1 Solidification point is measured by noting the maximum temperature reached during a controlled cooling cycle after the appearance of a solid phase.

#### 5. Significance and Use

5.1 This test method may be used as a criteria for determining the purity of benzene. The closer the solidification point reaches that of pure benzene, the purer the sample.

#### 6. Apparatus

6.1 *Benzene Container (Air Jacketed):*

6.1.1 *Inner Container*, a test tube 15 mm in outside diameter and 125 mm in length.

6.1.2 *Air Jacket*, a standard test tube 25 mm in outside diameter and 150 mm in length.

6.1.3 *Insulation*—Dry absorbent cotton or glass wool.

6.2 *Benzene Container (thick walled)*, a glass test tube 18 mm in outside diameter, 14 mm in inside diameter and 150 mm in length. The thick walled tube is only compatible with the thermistor.

6.3 *Ice Bath*, a 1-L beaker, or similar suitable container, having an effective depth of at least 127 mm and filled with chipped or shaved ice.

6.4 *Stirrer*, consisting of a 1-mm wire (copper or stainless steel) or a 2-mm glass rod with one end bent into a circular form at right angles to the shaft so that it will move freely in the annular space between the thermometer stem and the wall of the smaller test tube.

6.5 *Temperature Measurement Device*, either device described below has been found satisfactory.

6.5.1 *Thermometer*, an ASTM Benzene Freezing Point Thermometer having a range from 4.0 to 6.0°C and conforming to the requirements for Thermometer 112C as prescribed in Specification E1.

6.5.2 *Thermistor*, in stainless steel housing with resistance greater than 2K ohms at 25°C. Calibration accuracy 0.01°C. Drift in resistance equivalent to less than ±0.01°C/year. Thermistor shall be calibrated to cover the range it is used.

6.6 *Stirring Apparatus (Optional)*, the apparatus illustrated in Fig. 1 has been demonstrated to be an acceptable replacement for manually stirring the benzene solution.

6.7 *Ohmmeter*, capable of measuring resistance to the nearest 0.1 ohm in the range 1000 to 10 000 ohms with direct temperature readout.

## 7. Hazards

7.1 Consult current OSHA regulations, supplier's Safety Data Sheets, and local regulations for all materials used in this test method.

7.2 **Warning**—Mercury has been designated by EPA and many state agencies as a hazardous material that can cause central nervous system, kidney, and liver damage. Mercury, or its vapor, may be hazardous to health and corrosive to materials. Caution should be taken when handling mercury and mercury-containing products. See the applicable product 1 Safety Data Sheet (SDS) for details and EPA's website (<http://www.epa.gov/mercury/faq.htm>) for additional information. Users should be aware that selling mercury or mercury-containing products, or both, in your state may be prohibited by state law.

## 8. Sampling

8.1 Sample the material in accordance with Practice **D3437**.

## 9. Preparation of Apparatus

9.1 Fit the benzene container with a two-hole stopper. Through one hole insert the temperature measurement device. The thermometer should be inserted up to the 4.0°C mark. The thermistor should be inserted, so as to contact the benzene solution. Through the other hole insert the shaft of the stirrer.

9.2 If using the benzene container (air jacketed), place a 3.2-mm layer of dry absorbent cotton or glass wool in the bottom of the larger test tube and insert the inner container up to the lip into a stopper or annular ring that just fits into the mouth of the air jacket.

## 10. Calibration of Temperature Measuring Device

10.1 Calibration of ASTM thermometer 112C is accomplished with the small scale etched on the lower portion of the thermometer. Prepare an ice bath by filling a small Dewar flask with crushed ice made from Type I or Type II water (as specified in Specification **D1193**) and add just enough chilled Type I or Type II water to make a slurry. Immerse the thermometer in the ice bath, allow 5 min for the system to reach equilibrium and read the thermometer. Solidification point values are subsequently adjusted by adding (or subtracting) the number of degrees the thermometer is below (or above) 0.00°C.

10.2 Calibration of the thermistor is performed by the thermistor manufacturer. Resistance is converted to temperature using an equation supplied by the manufacturer.

## 11. Procedure

11.1 Saturate the sample of benzene with water as follows: Place 7 to 8 mL of the sample in the benzene container, add 1 drop of water, and shake the tube and contents vigorously.

11.2 Place the stopper and stirring apparatus (if any) into the benzene container.

11.3 When using the benzene container (air jacket), the operator may cool the smaller test tube and contents rapidly to about 6°C in the ice bath, while stirring. Wipe dry the outside of the smaller test tube and insert it into the larger test tube. Place the assembled tubes in the ice bath.

11.4 Stir the benzene continuously and observe the temperature closely. The temperature will fall to a minimum, then rise to a maximum, remain constant at this maximum for approximately 15 s, and then fall again (**Note 1**). The minimum temperature is due to super-cooling before solidification starts and shall not be more than 0.7°C below the maximum when using a thermometer. Record the maximum constant temperature observed to the nearest 0.01°C and designate it as "wet" (**Note 1**).

**NOTE 1**—If distinct minimum and maximum points are not evident, or if the temperature does not remain constant at the maximum for at least 15 s, the determination shall be repeated. The thermistor reading should remain constant to at least two places to the right of the decimal.

## 12. Report

12.1 Results shall be reported on the anhydrous basis. Since the determination is actually made on water-saturated benzene, the solidification point shall be corrected to the anhydrous basis by adding 0.09°C to the observed maximum temperature following the minimum. Corrections for accuracy of the thermometer shall be made.

## 13. Precision and Bias<sup>5</sup>

13.1 *Thermometer Precision*—The following criteria should be used to judge the acceptability of results obtained by this test method when using a thermometer. The criteria were determined by measuring the solidification point of a sample twelve times at one laboratory using a thermometer. The results of the intralaboratory study were calculated and analyzed using Practice **E691**. Duplicate results in the same laboratory should not be considered suspect unless they differ by more than 0.04°C.

13.2 *Thermistor Precision*—An ILS was conducted which included six laboratories analyzing three samples three times. Practice **E691** was followed for the design and analysis of the data. This ILS did not meet the minimum requirements of Practice **E691** which requires six labs, four materials, and two replicates.

13.2.1 *Intermediate Precision (formerly called Repeatability)*—Results in the same laboratory should not be considered suspect unless they differ more than 0.04°C. Results differing by less than 0.04°C have a 95 % probability of being correct.

13.2.2 *Reproducibility*—Results submitted by two laboratories should not be considered suspect unless they differ by more than 0.05°C. Results differing by less than 0.05°C have a 95 % probability of being correct.

<sup>5</sup> Supporting data have been filed at ASTM International Headquarters and may be obtained by requesting Research Report RR:D16-1028. Contact ASTM Customer Service at [service@astm.org](mailto:service@astm.org).