



Designation: D6484/D6484M – 20

Standard Test Method for Open-Hole Compressive Strength of Polymer Matrix Composite Laminates¹

This standard is issued under the fixed designation D6484/D6484M; the number immediately following the designation indicates the year of original adoption or, in the case of revision, the year of last revision. A number in parentheses indicates the year of last reappraisal. A superscript epsilon (ϵ) indicates an editorial change since the last revision or reappraisal.

1. Scope

1.1 This test method determines the open-hole compressive strength of multidirectional polymer matrix composite laminates reinforced by high-modulus fibers. The composite material forms are limited to continuous-fiber or discontinuous-fiber (tape or fabric, or both) reinforced composites in which the laminate is balanced and symmetric with respect to the test direction. The range of acceptable test laminates and thicknesses are described in 8.2.1.

1.2 Several related ASTM standards reference the procedures and apparatus described within this test method. In particular, the support fixture described in 7.2 is used by several other standards to stabilize compression-loaded test specimens. These include Practice D6742/D6742M, which covers filled-hole compression testing; Practice D7615/D7615M, which covers open-hole fatigue testing; and Practice D8066/D8066M, which covers unnotched laminate compression testing.

1.3 *Units*—The values stated in either SI units or inch-pound units are to be regarded separately as standard. The values stated in each system are not necessarily exact equivalents; therefore, to ensure conformance with the standard, each system shall be used independently of the other, and values from the two systems shall not be combined.

1.3.1 Within the text, the inch-pound units are shown in brackets.

1.4 *This standard does not purport to address all of the safety concerns, if any, associated with its use. It is the responsibility of the user of this standard to establish appropriate safety, health, and environmental practices and determine the applicability of regulatory limitations prior to use.*

1.5 *This international standard was developed in accordance with internationally recognized principles on standardization established in the Decision on Principles for the Development of International Standards, Guides and Recommendations issued by the World Trade Organization Technical Barriers to Trade (TBT) Committee.*

mentations issued by the World Trade Organization Technical Barriers to Trade (TBT) Committee.

2. Referenced Documents

2.1 ASTM Standards:²

- D792 Test Methods for Density and Specific Gravity (Relative Density) of Plastics by Displacement
- D883 Terminology Relating to Plastics
- D2584 Test Method for Ignition Loss of Cured Reinforced Resins
- D2734 Test Methods for Void Content of Reinforced Plastics
- D3039/D3039M Test Method for Tensile Properties of Polymer Matrix Composite Materials
- D3171 Test Methods for Constituent Content of Composite Materials
- D3878 Terminology for Composite Materials
- D5229/D5229M Test Method for Moisture Absorption Properties and Equilibrium Conditioning of Polymer Matrix Composite Materials
- D5687/D5687M Guide for Preparation of Flat Composite Panels with Processing Guidelines for Specimen Preparation
- D6742/D6742M Practice for Filled-Hole Tension and Compression Testing of Polymer Matrix Composite Laminates
- D7615/D7615M Practice for Open-Hole Fatigue Response of Polymer Matrix Composite Laminates
- D8066/D8066M Practice Unnotched Compression Testing of Polymer Matrix Composite Laminates
- E4 Practices for Force Verification of Testing Machines
- E6 Terminology Relating to Methods of Mechanical Testing
- E83 Practice for Verification and Classification of Extensometer Systems
- E122 Practice for Calculating Sample Size to Estimate, With Specified Precision, the Average for a Characteristic of a Lot or Process
- E177 Practice for Use of the Terms Precision and Bias in ASTM Test Methods
- E456 Terminology Relating to Quality and Statistics

¹ This test method is under the jurisdiction of ASTM Committee D30 on Composite Materials and is the direct responsibility of Subcommittee D30.05 on Structural Test Methods.

Current edition approved Oct. 1, 2020. Published November 2020. Originally approved in 1999. Last previous edition approved in 2014 as D6484/D6484M – 14. DOI: 10.1520/D6484_D6484M-20.

² For referenced ASTM standards, visit the ASTM website, www.astm.org, or contact ASTM Customer Service at service@astm.org. For *Annual Book of ASTM Standards* volume information, refer to the standard's Document Summary page on the ASTM website.

E691 Practice for Conducting an Interlaboratory Study to Determine the Precision of a Test Method

3. Terminology

3.1 *Definitions*—Terminology **D3878** defines terms relating to high-modulus fibers and their composites. Terminology **D883** defines terms relating to plastics. Terminology **E6** defines terms relating to mechanical testing. Terminology **E456** and Practice **E177** define terms relating to statistics. In the event of a conflict between terms, Terminology **D3878** shall have precedence over the other terminologies.

3.2 *Definitions of Terms Specific to This Standard:*

NOTE 1—If the term represents a physical quantity, its analytical dimensions are stated immediately following the term (or letter symbol) in fundamental dimension form, using the following ASTM standard symbology for fundamental dimensions, shown within square brackets: [*M*] for mass, [*L*] for length, [*T*] for time, [θ] for thermodynamic temperature, and [*nd*] for nondimensional quantities. Use of these symbols is restricted to analytical dimensions when used with square brackets, as the symbols may have other definitions when used without the brackets.

3.2.1 *diameter-to-thickness ratio, D/h [*nd*], n —in an open-hole specimen, the ratio of the hole diameter to the specimen thickness.*

3.2.1.1 *Discussion*—The diameter-to-thickness ratio may be either a nominal value determined from nominal dimensions or an actual value determined from measured dimensions.

3.2.2 *nominal value, n —a value, existing in name only, assigned to a measurable property for the purpose of convenient designation. Tolerances may be applied to a nominal value to define an acceptable range for the property.*

3.2.3 *width-to-diameter ratio, w/D [*nd*], n —in an open-hole specimen, the ratio of the specimen width to the hole diameter.*

3.2.3.1 *Discussion*—The width-to-diameter ratio may be either a nominal value determined from nominal dimensions or an actual value determined from measured dimensions.

3.3 *Symbols:*

A—cross-sectional area of a specimen

CV—coefficient of variation statistic of a sample population for a given property (in percent)

B_z —edgewise percent bending

D—hole diameter

h—specimen thickness

n—number of specimens per sample population

N—number of plies in laminate under test

F_x^{ohcu} —ultimate open hole (notched) compressive strength in the test direction

P_{max} —maximum force carried by test specimen before failure

r—95 % repeatability confidence limit, equal to 2.8 times the repeatability standard deviation

R—95 % reproducibility confidence limit, equal to 2.8 times the reproducibility standard deviation

S_{n-1} —standard deviation statistic of a sample population for a given property

S_r —repeatability (within laboratory precision) standard deviation, calculated in accordance with Practice **E691**

S_R —reproducibility (between laboratory precision) standard deviation, calculated in accordance with Practice **E691**

w—specimen width

x_1 —test result for an individual specimen from the sample population for a given property

\bar{x} —mean or average (estimate of mean) of a sample population for a given property

σ —normal stress

4. Summary of Test Method

4.1 A uniaxial compression test of a balanced, symmetric laminate is performed with a centrally located hole. Edge-mounted extensometer displacement transducers are optional. Ultimate strength is calculated based on the gross cross-sectional area, disregarding the presence of the hole. While the hole causes a stress concentration and reduced net section, it is common aerospace practice to develop notched design allowable strengths based on gross section stress to account for various stress concentrations (fastener holes, free edges, flaws, damage, and so forth) not explicitly modeled in the stress analysis.

4.2 The test specimen is face-supported in a multi-piece bolted support fixture. Two acceptable test procedures are provided. In Procedure A, the specimen/fixture assembly is clamped in hydraulic wedge grips. The force is transmitted by shear into the support fixture and then is transmitted by shear into the test specimen. In Procedure B, the specimen/fixture assembly is placed between flat platens, such that the specimen and fixture are end-loaded. The portion of the force initially transferred into the support fixture is transmitted by shear into the test specimen.

4.3 The only acceptable failure mode for ultimate open-hole compressive strength is one which passes through the hole in the test specimen.

5. Significance and Use

5.1 This test method is designed to produce notched compressive strength data for structural design allowables, material specifications, research and development, and quality assurance. Factors that influence the notched compressive strength and shall therefore be reported include the following: material, methods of material fabrication, accuracy of lay-up, laminate stacking sequence and overall thickness, specimen geometry, (including hole diameter, diameter-to-thickness ratio, and width-to-diameter ratio), specimen preparation (especially of the hole), specimen conditioning, environment of testing, specimen alignment and gripping, loading procedure, speed of testing, time at temperature, void content, and volume percent reinforcement. Properties that may be derived from this test method include open-hole (notched) compressive strength (OHC).

6. Interferences

6.1 *Hole Preparation*—Because of the dominating presence of the notch, and the lack of need to measure the material response, results from this test method are relatively insensitive to parameters that would be of concern in an unnotched compressive property test. However, since the notch dominates the strength, consistent preparation of the hole, without damage to the laminate, is important to meaningful results. Damage

caused by hole preparation will affect strength results. Some types of damage, such as longitudinal splitting and delamination, can blunt the stress concentration caused by the hole, increasing the force-carrying capacity of the specimen and the calculated strength. Other types of damage can reduce the calculated strength.

6.2 Specimen Geometry—Results are affected by the ratio of specimen width to hole diameter (w/D); this ratio should be maintained at 6, unless the experiment is investigating the influence of this ratio. Results may also be affected by the ratio of hole diameter to thickness (D/h); the preferred ratio is the range from 1.5 to 3.0, unless the experiment is investigating the influence of this ratio. Results may also be affected by the ratio of ungripped specimen length to specimen width; this ratio should be maintained at 2.7, unless the experiment is investigating the influence of this ratio.

6.3 Support Fixture—Results are affected by the amount of lateral pressure applied to the test specimen by the support fixture. Sources of variation in this lateral pressure include fixture bolt torque, hydraulic gripping pressure, and fixture shimming choices, and should be controlled and reported as required in the *Procedure* and *Report* sections. The support fixture can inhibit the growth of delamination damage by inhibiting out-of-plane deformation beyond the cutout, and by relieving force from the specimen via friction effects. This may result in non-conservative data.

6.4 Material Orthotropy—The degree of laminate orthotropy strongly affects the failure mode and measured OHC strength. Valid OHC strength results should only be reported when appropriate failure modes are observed, in accordance with 11.9.

6.5 Thickness Scaling—Thick composite structures do not necessarily fail at the same strengths as thin structures with the same laminate orientation (that is, strength does not always scale linearly with thickness). Thus, data gathered using this test method may not translate directly into equivalent thick-structure properties.

6.6 Type of Loading—Differences in force versus crosshead displacement and force versus extensometer strain response may be observed when comparing hydraulic grip-loaded specimens with end-loaded specimens. Hydraulic grip-loaded data typically exhibit linear behavior at the onset of loading. At high force levels, some nonlinear behavior may be observed due to grip slippage. End-loaded data typically display some initial nonlinear behavior at low force levels, due to seating of the specimen/fixture assembly underneath the load platens, but then exhibit linear behavior to failure.

7. Apparatus

7.1 Micrometers and Calipers—A micrometer with a 4 to 8 mm [0.16 to 0.32 in.] nominal diameter ball interface or a flat anvil interface shall be used to measure the specimen thickness. A ball interface is recommended for thickness measurements when at least one surface is irregular (for example, a coarse peel ply surface which is neither smooth nor flat). A micrometer or caliper with a flat anvil interface shall be used for measuring length, width, and other machined surface

dimensions. The use of alternative measurement devices is permitted if specified (or agreed to) by the test requestor and reported by the testing laboratory. The accuracy of the instruments shall be suitable for reading to within 1 % of the specimen dimensions. For typical specimen geometries, an instrument with an accuracy of ± 0.0025 mm [± 0.0001 in.] is adequate for the thickness measurement, while an instrument with an accuracy of ± 0.025 mm [± 0.001 in.] is adequate for measurement of length, width, and other machined surface dimensions. Additionally, a micrometer or gage capable of determining the hole diameter to ± 0.025 mm [± 0.001 in.] shall be used.

7.2 Support Fixture—The fixture is a face-supported compressive test fixture as shown in Fig. 1. The fixture consists of two short-grip/long-grip assemblies, two support plates, and steel shims as required to maintain a nominally zero (0.00 to 0.12 mm [0.000 to 0.005 in.] tolerance) gap between support plates and long grips. If this gap does not meet the minimum requirement, shim the contact area between the support plate and the short grip with steel shim stock. If the gap is too large, shim between the support plate and the long grip, holding the shim stock on the support plate with tape. Fig. 2 shows shim requirements. The fixture should be checked for conformity to engineering drawings. Each short-grip/long-grip assembly is line-drilled as shown in Figs. 3 and 4 and must be used as a matched set. The threading of the support plate is optional. Standard test specimens are 36 by 300 mm [1.5 by 12 in.]. In Procedure A, the fixture is hydraulically gripped on each end and the compressive force is transmitted by means of friction through the fixture and into the test specimen. In Procedure B, the fixture is placed between flat platens and loaded in compression at each end; force introduced into the fixture is transmitted by means of friction into the test specimen. A cutout exists on both faces of the fixture for a thermocouple, fastener, or extensometer, if required by the requesting organization. The long and short fixtures have an undercut along the corner of the specimen grip area so that specimens are not required to be chamfered and to avoid damage caused by the radius. The fixtures also allow a slight clearance between the fixture and the gage section of the specimen, in order to minimize grip failures and friction effects.

7.2.1 Support Fixture Details—The detailed drawings for manufacturing the support fixture are contained in Figs. 5-12. An optional threaded support plate is shown in Figs. 13 and 14, to be used instead of the support plate shown in Figs. 11 and 12 and the nuts called out in Fig. 1. Other fixtures that meet the requirements of this section may be used (for example, MTS Open Hole Compressive Fixture Model 605.21A or Wyoming Test Fixtures, Inc. Models CU-OH and WTF-OH). The following general notes apply to these figures:

7.2.1.1 Machine surfaces to a 3.2 [125] finish unless otherwise specified.

7.2.1.2 Break all edges.

7.2.1.3 Specimen-gripping area shall be thermal sprayed using high-velocity oxygen fueled (HVOF), electrospark deposition (ESD), or equivalent process.

7.2.1.4 The test fixture may be made of low-carbon steel for ambient temperature testing. For non-ambient environmental

METRIC HARDWARE
 NA0036-060050 BOLT (4)
 NA0179B-060 WASHER (8+)
 (# AS REQ'D)
 NA0033-060M NUT (4)
 (OR EQUIVALENT)
 OR
 FOR THREADED PLATES
 NA0036-060045 BOLT (4)
 NA0179B-060 WASHER (4)
 (OR EQUIVALENT)

US CUSTOMARY HARDWARE
 NAS 6605-32 BOLT (4)
 NAS 1587-5C WASHER (8+)
 (# AS REQ'D.)
 NAS 1804-5 NUT (4)
 [OR EQUIVALENT]
 OR
 FOR THREADED PLATES
 NAS6605-28 BOLT (4)
 NAS 1587-5C WASHER (4)
 [OR EQUIVALENT]

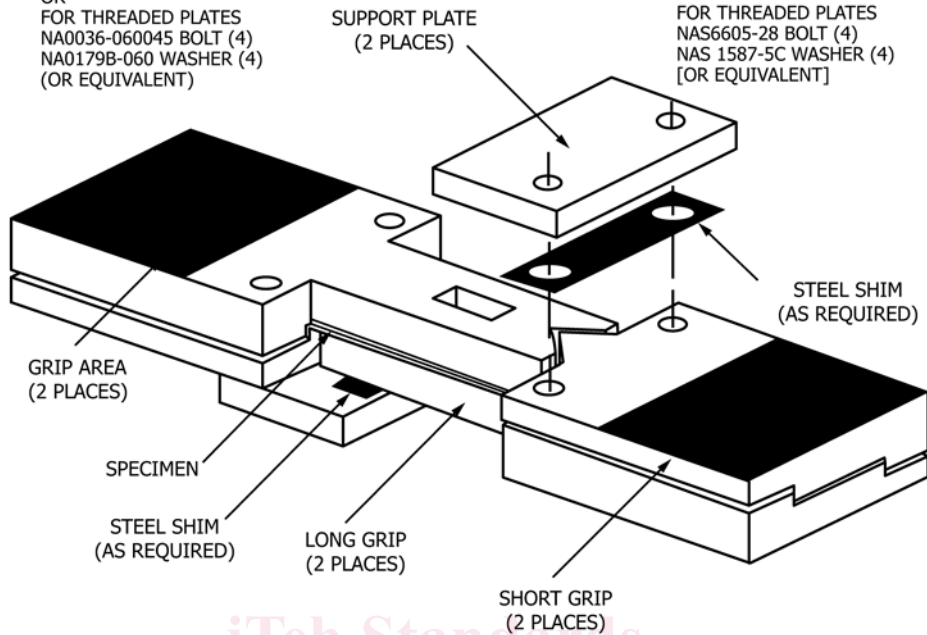

FIG. 1 Support Fixture Assembly

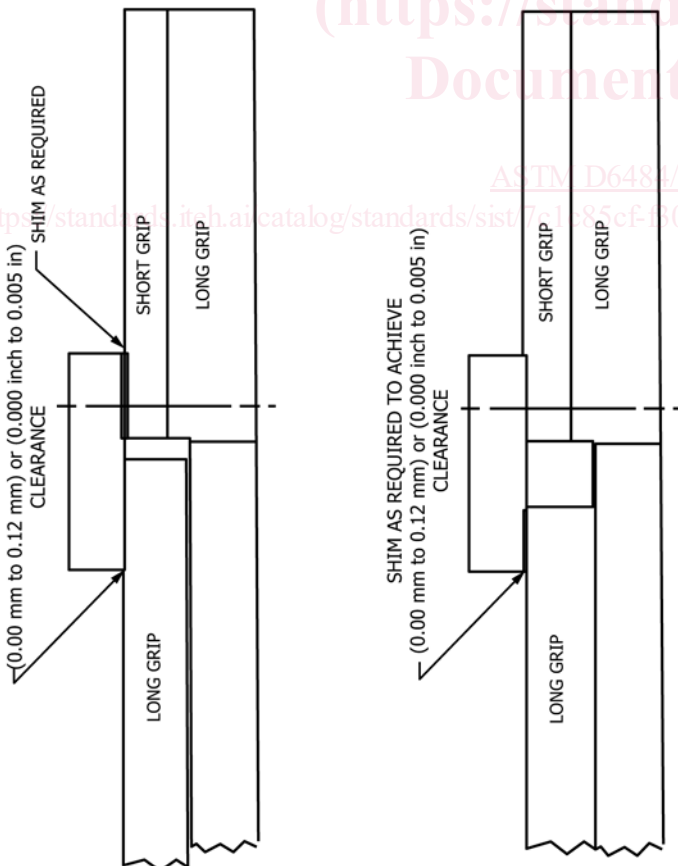

FIG. 2 Support Fixture—Shim Requirements

conditions, the recommended fixture material is a nonheat-treated ferritic or precipitation-hardened stainless steel (heat treatment for improved durability is acceptable but not required).

7.2.1.5 Additional fasteners may be installed in the gripping area (shown in Figs. 3 and 4) when using Procedure B. The presence of such fasteners is not required to perform an end-loaded test successfully. However, they can be beneficial in suppressing unacceptable failure modes (such as end failures) in certain circumstances (high temperature testing, for example) by ensuring that the specimen is well-supported by the fixture.

NOTE 2—Experience has shown that fixtures may be damaged in use, thus periodic reinspection of the fixture dimensions and tolerances is important.

7.3 Testing Machine—The testing machine shall be in accordance with Practices E4 and shall satisfy the following requirements:

7.3.1 Testing Machine Configuration—The testing machine shall have both an essentially stationary head and a movable head. A short loading train, and either rigidly mounted hydraulic grips or flat end-loading platens, shall be used.

7.3.2 Grips—If Procedure A is used, each head of the testing machine shall be capable of holding one end of the test assembly so that the direction of force applied to the specimen is coincident with the longitudinal axis of the specimen. Hydraulic wedge grips shall apply sufficient lateral pressure to prevent slippage between the grip face and the support fixture.

7.3.3 Flat Platens—If Procedure B is used, the test machine shall be mounted with well-aligned, fixed (as opposed to

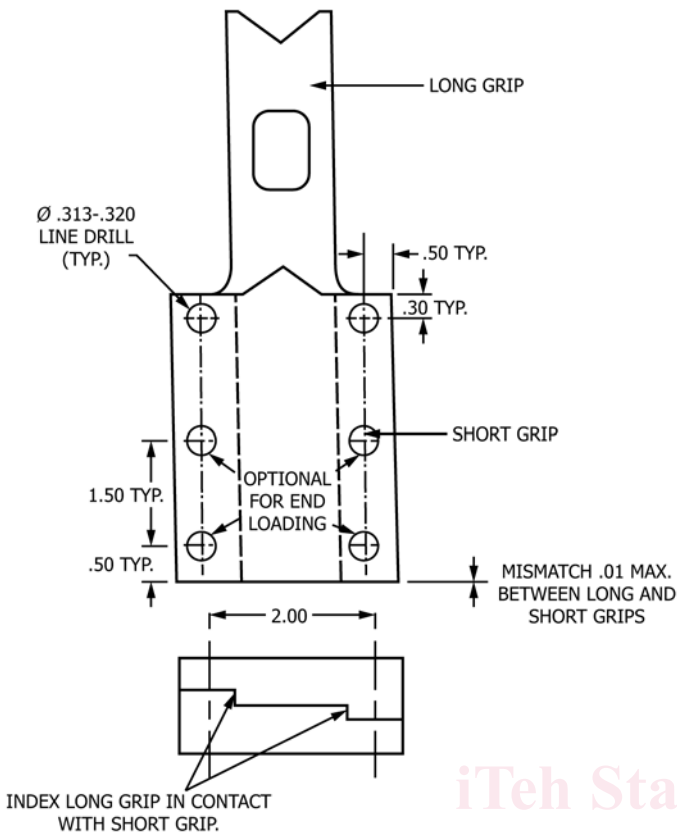

FIG. 3 Support Fixture—Line Drilling Details (Inch-Pound Version)

NOTE 1—
 (a) All dimensions in inches.
 (b) The long grip and short grip should be part marked with a unique test fixture assembly identification.
 (c) Tolerance except as noted is linear ± 0.01 in.

spherical seat) flat platens. The platen surfaces shall be parallel within 0.03 mm [0.001 in.] across the test fixture base length of 80 mm [3.0 in.]. If the platens are not sufficiently hardened, or simply to protect the platen surfaces, a hardened plate (with parallel surfaces) can be inserted between each end of the fixture and the corresponding platen. A rectangle should be drawn on the center of the lower platen, to help center the test fixture between the platens.

7.3.4 Drive Mechanism—The testing machine drive mechanism shall be capable of imparting to the movable head a controlled velocity with respect to the stationary head. The velocity of the movable head shall be capable of being regulated in accordance with 11.3.

7.3.5 Load Indicator—The testing machine load-sensing device shall be capable of indicating the total force being carried by the test specimen. This device shall be essentially free from inertia lag at the specified rate of testing and shall

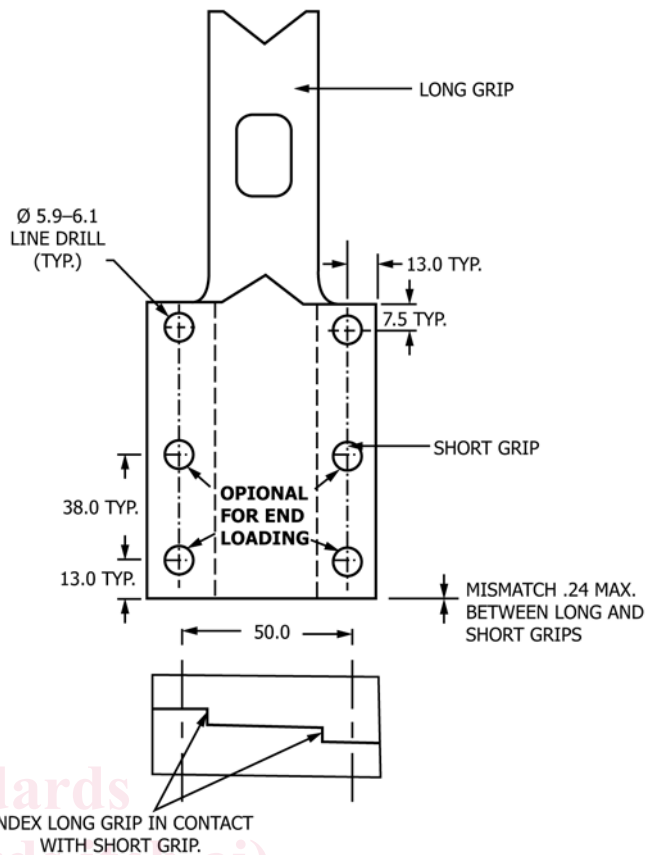

FIG. 4 Support Fixture—Line Drilling Details (SI Version)

NOTE 1—
 (a) All dimensions in mm.
 (b) The long grip and short grip should be part marked with a unique test fixture assembly identification.
 (c) Tolerance except as noted is linear ± 0.24 mm.

indicate the force with an accuracy over the force range(s) of interest of within $\pm 1\%$ of the indicated value.

7.3.6 Extensometers—The extensometer gage length shall be 25 mm [1.0 in.]. Extensometers shall satisfy, at a minimum, Practice E83, Class B-1 requirements for the strain range of interest, and shall be calibrated over that range in accordance with Practice E83. The extensometers shall be essentially free of inertia lag at the specified speed of testing.

7.4 Conditioning Chamber—When conditioning materials at non-laboratory environments, a temperature/vapor-level controlled environmental conditioning chamber is required that shall be capable of maintaining the required temperature to within $\pm 3\text{ }^\circ\text{C}$ [$\pm 5\text{ }^\circ\text{F}$] and the required relative humidity level to within $\pm 3\%$ RH. Chamber conditions shall be monitored either on an automated continuous basis or on a manual basis at regular intervals.

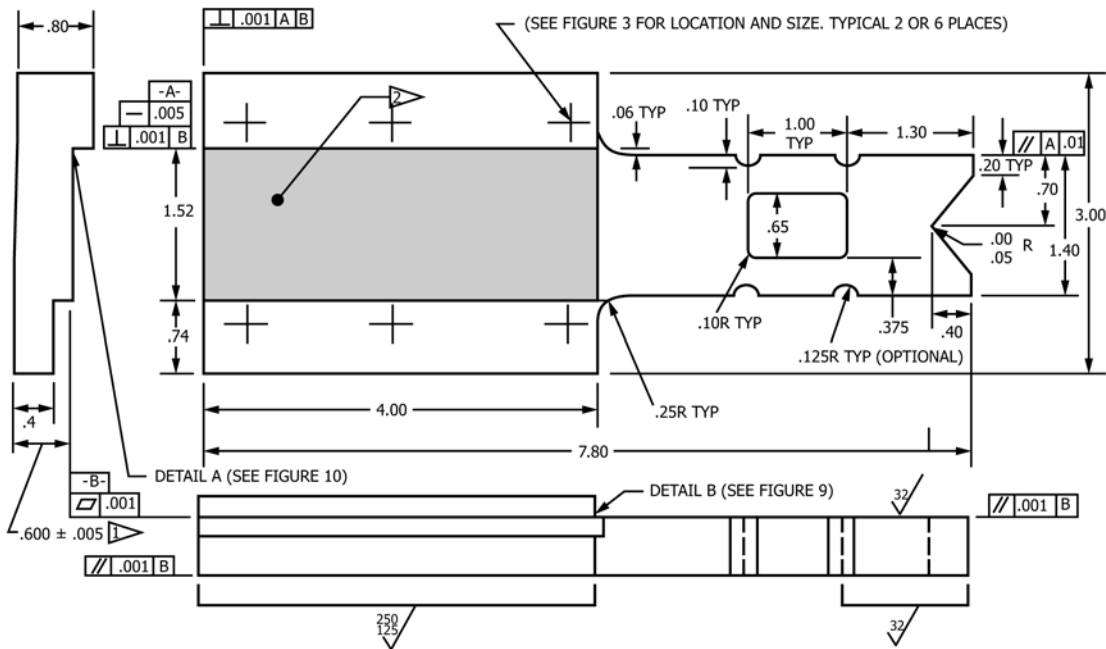

NOTE 1—See 7.2.1 for general notes.
 (Flag symbol 1) For existing fixtures, this dimension is 0.60 ± 0.02 ; however, all four fittings must be within ± 0.005 of each other.
 (Flag symbol 2) Thermal spray surface using either high velocity oxygen fueled (HVOF) process or electrospark deposition (ESD) process.

FIG. 5 Support Fixture—Long Grip Details (Inch-Pound Version)

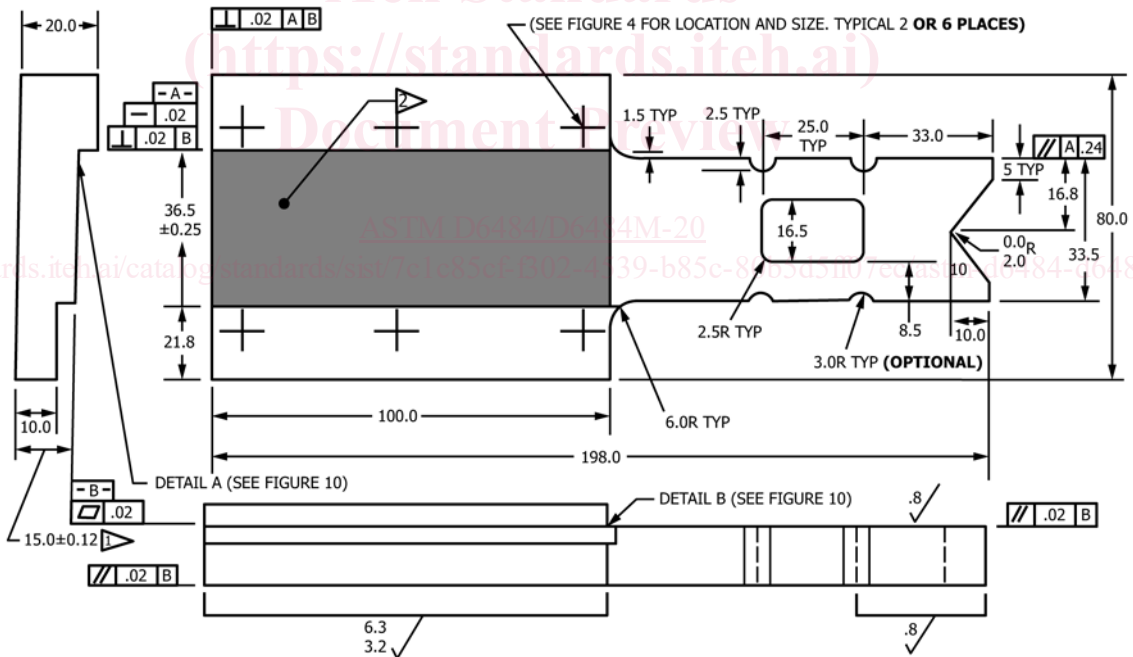

NOTE 1—See 7.2.1 for general notes.
 (Flag symbol 1) For existing fixtures, this dimension is 15 ± 0.5 ; however, all four fittings must be within ± 0.12 of each other.
 (Flag symbol 2) Thermal spray surface using either high velocity oxygen fueled (HVOF) process or electrospark deposition (ESD) process.

FIG. 6 Support Fixture—Long Grip Details (SI Version)

7.5 Environmental Test Chamber—An environmental test chamber is required for test environments other than ambient testing laboratory conditions. This chamber shall be capable of maintaining the test specimen and fixture at the required test

environment during the mechanical test. The test temperature shall be maintained within $\pm 3^\circ\text{C}$ [$\pm 5^\circ\text{F}$] of the required temperature, and the relative humidity level shall be maintained to within $\pm 3\%$ RH of the required humidity level.

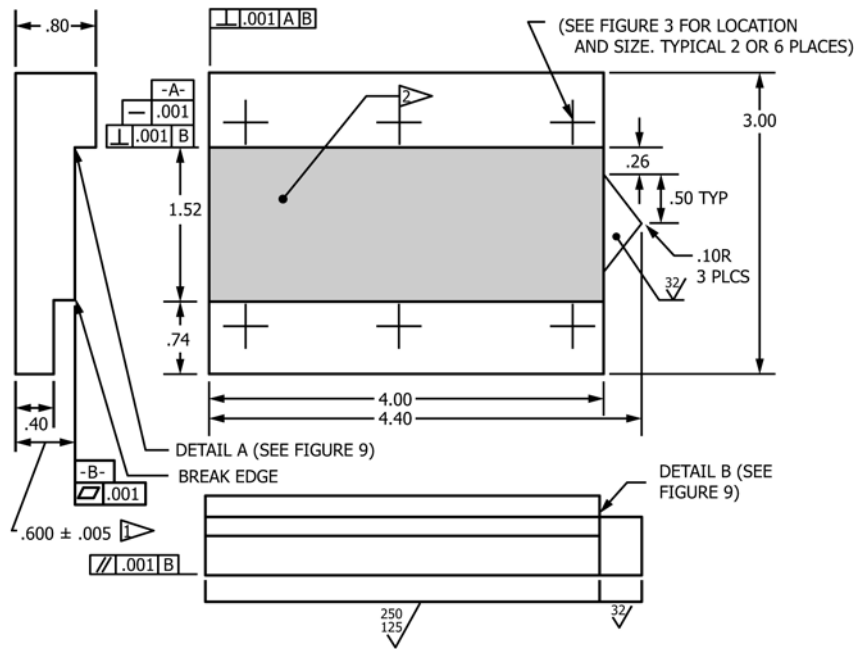

NOTE 1—See 7.2.1 for general notes.
 (Flag symbol 1) For existing fixtures, this dimension is 0.60 ± 0.02 ; however, all four fittings must be within ± 0.005 of each other.
 (Flag symbol 2) Thermal spray surface using either high velocity oxygen fueled (HVOF) process or electrospark deposition (ESD) process.

FIG. 7 Support Fixture—Short Grip Details (Inch-Pound Version)

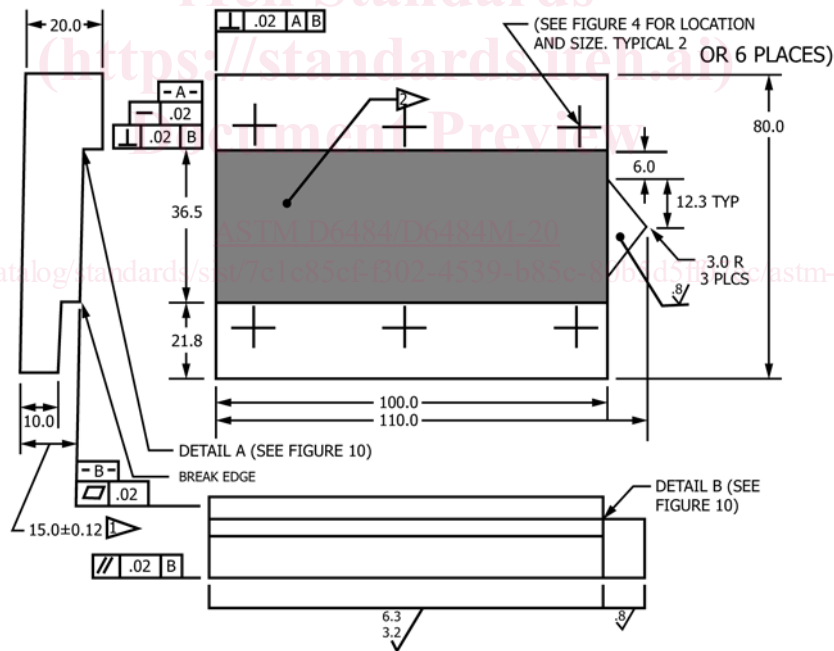

NOTE 1—See 7.2.1 for general notes.
 (Flag symbol 1) For existing fixtures, this dimension is 15.0 ± 0.5 ; however, all four fittings must be within ± 0.12 of each other.
 (Flag symbol 2) Thermal spray surface using either high velocity oxygen fueled (HVOF) process or electrospark deposition (ESD) process.

FIG. 8 Support Fixture—Short Grip Details (SI Version)

8. Sampling and Test Specimens

8.1 *Sampling*—Test at least five specimens per test condition unless valid results can be gained through the use of fewer specimens, as in the case of a designed experiment. For

statistically significant data, consult the procedures outlined in Practice E122. Report the method of sampling.

8.2 Geometry: