



Designation: D7136/D7136M – 20

Standard Test Method for Measuring the Damage Resistance of a Fiber-Reinforced Polymer Matrix Composite to a Drop-Weight Impact Event¹

This standard is issued under the fixed designation D7136/D7136M; the number immediately following the designation indicates the year of original adoption or, in the case of revision, the year of last revision. A number in parentheses indicates the year of last reappraisal. A superscript epsilon (ϵ) indicates an editorial change since the last revision or reappraisal.

1. Scope

1.1 This test method determines the damage resistance of multidirectional polymer matrix composite laminated plates subjected to a drop-weight impact event. The composite material forms are limited to continuous-fiber reinforced polymer matrix composites, with the range of acceptable test laminates and thicknesses defined in 8.2.

1.1.1 Instructions for modifying these procedures to determine damage resistance properties of sandwich constructions are provided in Practice D7766/D7766M.

1.2 A flat, rectangular composite plate is subjected to an out-of-plane, concentrated impact using a drop-weight device with a hemispherical impactor. The potential energy of the drop-weight, as defined by the mass and drop height of the impactor, is specified prior to test. Equipment and procedures are provided for optional measurement of contact force and velocity during the impact event. The damage resistance is quantified in terms of the resulting size and type of damage in the specimen.

1.3 The test method may be used to screen materials for damage resistance, or to inflict damage into a specimen for subsequent damage tolerance testing. When the impacted plate is tested in accordance with Test Method D7137/D7137M, the overall test sequence is commonly referred to as the Compression After Impact (CAI) method. Quasi-static indentation per Test Method D6264/D6264M may be used as an alternate method of creating damage from an out-of-plane force and measuring damage resistance properties.

1.4 The damage resistance properties generated by this test method are highly dependent upon several factors, which include specimen geometry, layup, impactor geometry, impactor mass, impact force, impact energy, and boundary conditions. Thus, results are generally not scalable to other configurations, and are particular to the combination of geometric and physical conditions tested.

¹ This test method is under the jurisdiction of ASTM Committee D30 on Composite Materials and is the direct responsibility of Subcommittee D30.05 on Structural Test Methods.

Current edition approved Oct. 1, 2020. Published November 2020. Originally approved in 2005. Last previous edition approved in 2015 as D7136/D7136M – 15. DOI: 10.1520/D7136_D7136M-20.

1.5 *Units*—The values stated in either SI units or inch-pound units are to be regarded separately as standard. The values stated in each system are not necessarily exact equivalents; therefore, to ensure conformance with the standard, each system shall be used independently of the other, and values from the two systems shall not be combined.

1.5.1 Within the text, the inch-pound units are shown in brackets.

1.6 *This standard does not purport to address all of the safety concerns, if any, associated with its use. It is the responsibility of the user of this standard to establish appropriate safety, health, and environmental practices and determine the applicability of regulatory limitations prior to use.*

1.7 *This international standard was developed in accordance with internationally recognized principles on standardization established in the Decision on Principles for the Development of International Standards, Guides and Recommendations issued by the World Trade Organization Technical Barriers to Trade (TBT) Committee.*

2. Referenced Documents

- 2.1 *ASTM Standards:*²
- D792 Test Methods for Density and Specific Gravity (Relative Density) of Plastics by Displacement
 - D883 Terminology Relating to Plastics
 - D2584 Test Method for Ignition Loss of Cured Reinforced Resins
 - D2734 Test Methods for Void Content of Reinforced Plastics
 - D3171 Test Methods for Constituent Content of Composite Materials
 - D3763 Test Method for High Speed Puncture Properties of Plastics Using Load and Displacement Sensors
 - D3878 Terminology for Composite Materials
 - D5229/D5229M Test Method for Moisture Absorption Properties and Equilibrium Conditioning of Polymer Matrix Composite Materials
 - D5687/D5687M Guide for Preparation of Flat Composite

² For referenced ASTM standards, visit the ASTM website, www.astm.org, or contact ASTM Customer Service at service@astm.org. For *Annual Book of ASTM Standards* volume information, refer to the standard's Document Summary page on the ASTM website.

Panels with Processing Guidelines for Specimen Preparation

D6264/D6264M Test Method for Measuring the Damage Resistance of a Fiber-Reinforced Polymer-Matrix Composite to a Concentrated Quasi-Static Indentation Force

D7137/D7137M Test Method for Compressive Residual Strength Properties of Damaged Polymer Matrix Composite Plates

D7766/D7766M Practice for Damage Resistance Testing of Sandwich Constructions

E4 Practices for Force Verification of Testing Machines

E6 Terminology Relating to Methods of Mechanical Testing

E18 Test Methods for Rockwell Hardness of Metallic Materials

E122 Practice for Calculating Sample Size to Estimate, With Specified Precision, the Average for a Characteristic of a Lot or Process

E177 Practice for Use of the Terms Precision and Bias in ASTM Test Methods

E456 Terminology Relating to Quality and Statistics

E2533 Guide for Nondestructive Testing of Polymer Matrix Composites Used in Aerospace Applications

2.2 *Military Standards:*

CMH-17-3G Composite Materials Handbook, Volume 3—Polymer Matrix Composites Materials Usage, Design and Analysis³

MIL-HDBK-728/1 Nondestructive Testing⁴

MIL-HDBK-731A Nondestructive Testing Methods of Composite Materials—Thermography⁴

MIL-HDBK-732A Nondestructive Testing Methods of Composite Materials—Acoustic Emission⁴

MIL-HDBK-733A Nondestructive Testing Methods of Composite Materials—Radiography⁴

MIL-HDBK-787A Nondestructive Testing Methods of Composite Materials—Ultrasonics⁴

NASA Reference Publication 1092 Standard Tests for Toughened Resin Composites, Revised Edition, July 1983⁵

3. Terminology

3.1 *Definitions*—Terminology **D3878** defines terms relating to composite materials. Terminology **D883** defines terms relating to plastics. Terminology **E6** defines terms relating to mechanical testing. Terminology **E456** and Practice **E177** define terms relating to statistics. In the event of a conflict between terms, Terminology **D3878** shall have precedence over the other standards.

3.2 *Definitions of Terms Specific to This Standard:*

3.2.1 If the term represents a physical quantity, its analytical dimensions are stated immediately following the term (or letter symbol) in fundamental dimension form, using the following ASTM standard symbology for fundamental dimensions,

³ Available from SAE International (SAE), 400 Commonwealth Dr., Warrendale, PA 15096-0001, <http://www.sae.org>.

⁴ Available from U.S. Army Materials Technology Laboratory, Watertown, MA 02471.

⁵ Available from National Aeronautics and Space Administration (NASA)-Langley Research Center, Hampton, VA 23681-2199.

shown within square brackets: $[M]$ for mass, $[L]$ for length, $[T]$ for time, $[\theta]$ for thermodynamic temperature, and $[nd]$ for non-dimensional quantities. Use of these symbols is restricted to analytical dimensions when used with square brackets, as the symbols may have other definitions when used without the brackets.

3.2.2 *dent depth, d $[L]$, n* —residual depth of the depression formed by an impactor after the impact event.

3.2.2.1 *Discussion*—The dent depth shall be defined as the maximum distance in a direction normal to the face of the specimen from the lowest point in the dent to the plane of the impacted surface that is undisturbed by the dent.

3.2.3 *nominal value, n* —a value, existing in name only, assigned to a measurable property for the purpose of convenient designation.

3.2.3.1 *Discussion*—Tolerances may be applied to a nominal value to define an acceptable range for the property.

3.2.4 *recorded contact force, F $[MLT^{-2}]$, n* —the force exerted by the impactor on the specimen during the impact event, as recorded by a force indicator.

3.2.5 *striker tip, n* —the portion or component of the impactor which comes into contact with the test specimen first during the impact event.

3.3 *Symbols:*

A = cross-sectional area of a specimen

C_E = specified ratio of impact energy to specimen thickness

CV = coefficient of variation statistic of a sample population for a given property (in percent)

D = damage diameter (see Fig. 11)

d = dent depth

E = potential energy of impactor prior to drop

E_1 = absorbed energy at the time at which force versus time curve has a discontinuity in force or slope

E_a = energy absorbed by the specimen during the impact event

E_i = actual impact energy (incident kinetic energy)

E_{max} = absorbed energy at the time of maximum recorded contact force

F = recorded contact force

F_1 = recorded contact force at which the force versus time curve has a discontinuity in force or slope

F_{max} = maximum recorded contact force

g = acceleration due to gravity

h = specimen thickness

H = impactor drop height

l = specimen length

m = impactor mass

m_d = impactor mass for drop height calculation

m_{dlbm} = impactor mass in standard gravity for drop height calculation

n = number of specimens per sample population

N = number of plies in laminate under test

S_{n-1} = standard deviation statistic of a sample population for a given property

t = time during impactor drop and impact event

t_i = time of initial contact

t_T = contact duration (total duration of the impact event)

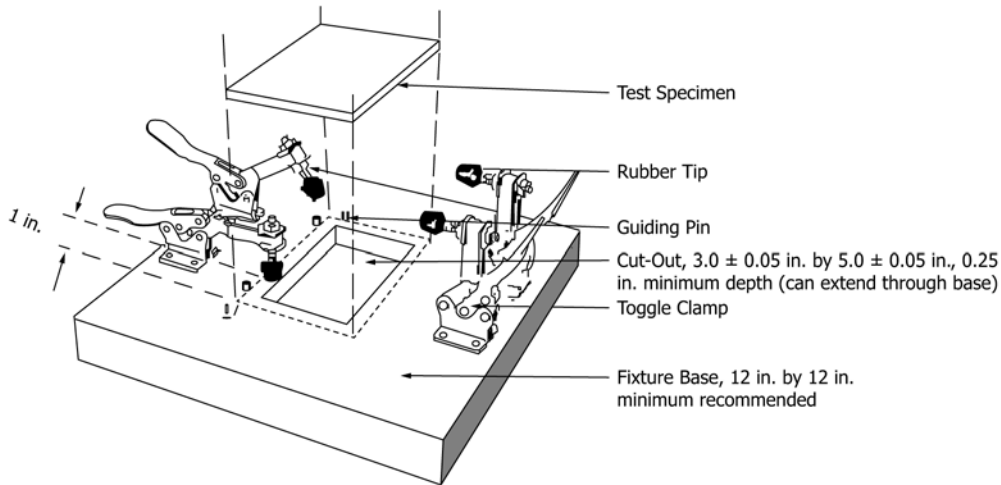

NOTE 1—Clamp tip centered 0.25 in. from edge of cut-out.

FIG. 1 Impact Support Fixture (Inch-Pound Version)

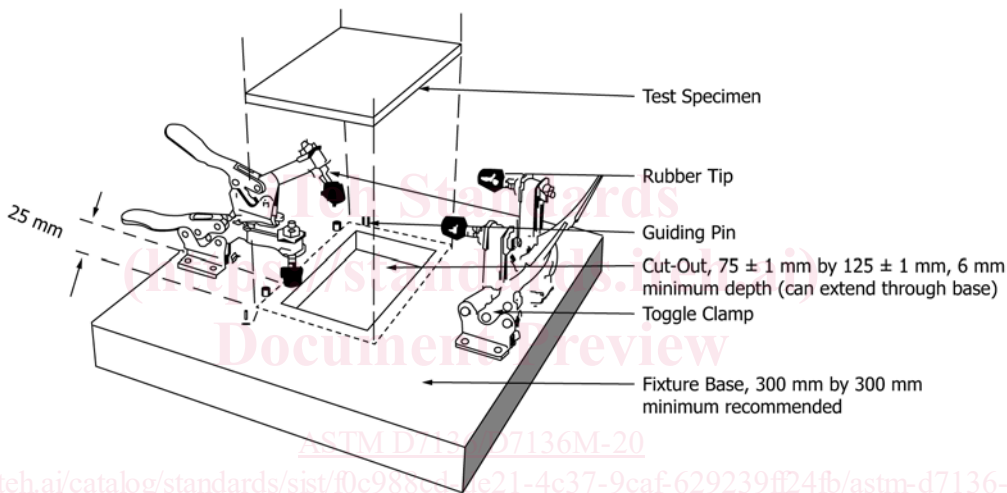

NOTE 1—Clamp tip centered 6 mm from edge of cut-out.

FIG. 2 Impact Support Fixture (SI Version)

w = specimen width

v = impactor velocity

v_i = impactor velocity at time of initial contact, t_i

W_{12} = distance between leading edges of the two flag prongs on velocity indicator

x_i = test result for an individual specimen from the sample population for a given property

\bar{x} = mean or average (estimate of mean) of a sample population for a given property

δ = impactor displacement

4. Summary of Test Method

4.1 A drop-weight impact test is performed using a balanced, symmetric laminated plate. Damage is imparted through out-of-plane, concentrated impact (perpendicular to the plane of the laminated plate) using a drop weight with a hemispherical striker tip. The damage resistance is quantified in terms of the resulting size and type of damage in the specimen. The damage response is a function of the test

configuration; comparisons cannot be made between materials unless identical test configurations, test conditions, and so forth are used.

4.2 Optional procedures for recording impact velocity and applied contact force versus time history data are provided.

4.3 Preferred damage states resulting from the impact are located in the center of the plate, sufficiently far from the plate edges such that the local states of stress at the edges and at the impact location do not interact during the damage formation event.

5. Significance and Use

5.1 Susceptibility to damage from concentrated out-of-plane impact forces is one of the major design concerns of many structures made of advanced composite laminates. Knowledge of the damage resistance properties of a laminated composite plate is useful for product development and material selection.

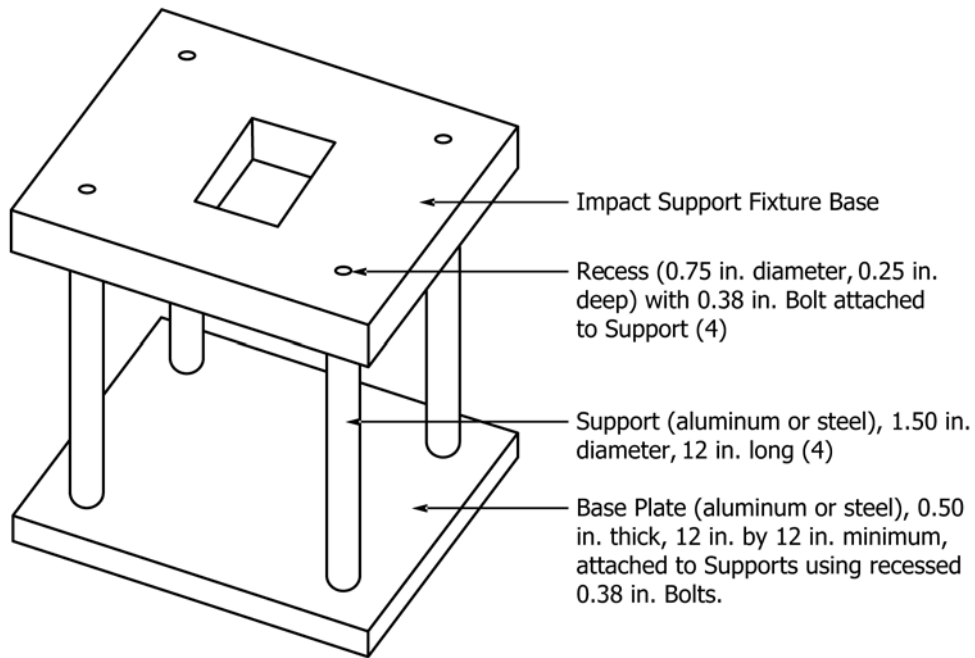

FIG. 3 Representative Rigid Base (Inch-Pound Version)

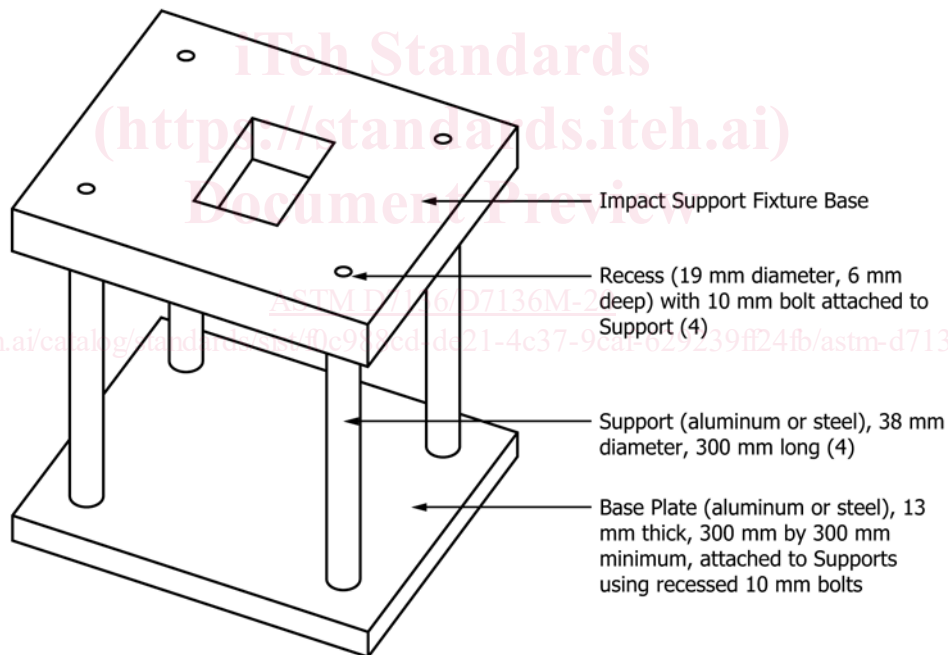

FIG. 4 Representative Rigid Base (SI Version)

5.2 Drop-weight impact testing can serve the following purposes:

5.2.1 To establish quantitatively the effects of stacking sequence, fiber surface treatment, variations in fiber volume fraction, and processing and environmental variables on the damage resistance of a particular composite laminate to a concentrated drop-weight impact force or energy.

5.2.2 To compare quantitatively the relative values of the damage resistance parameters for composite materials with different constituents. The damage response parameters can

include dent depth, damage dimensions, and through-thickness locations, F_1 , F_{max} , E_1 , and E_{max} , as well as the force versus time curve.

5.2.3 To impart damage in a specimen for subsequent damage tolerance tests, such as Test Method [D7137/D7137M](#).

5.3 The properties obtained using this test method can provide guidance in regard to the anticipated damage resistance capability of composite structures of similar material, thickness, stacking sequence, and so forth. However, it must be

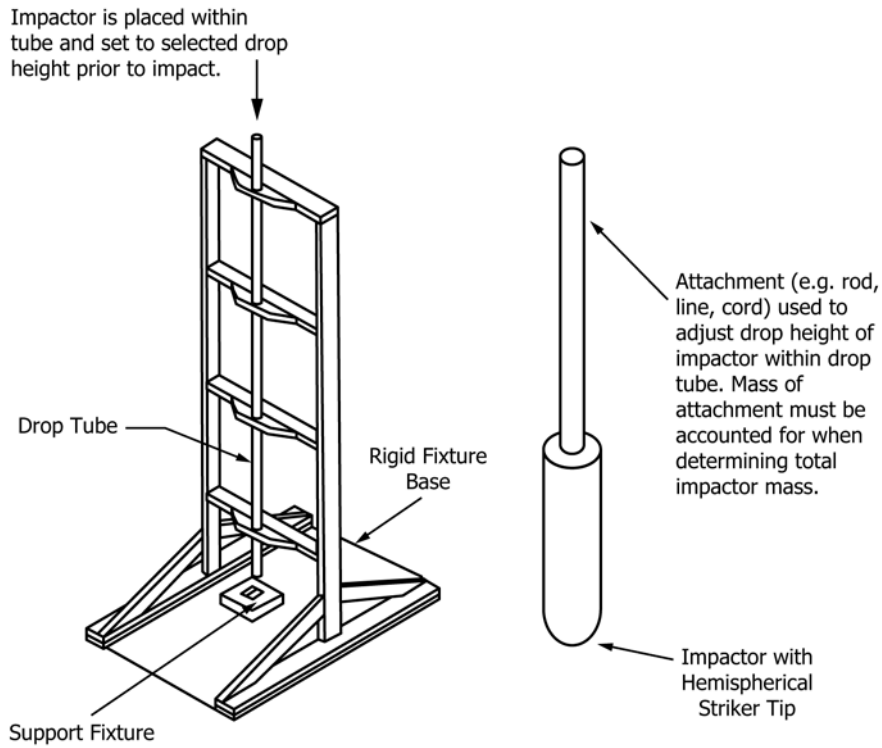

FIG. 5 Impact Device with Cylindrical Tube Impactor Guide Mechanism

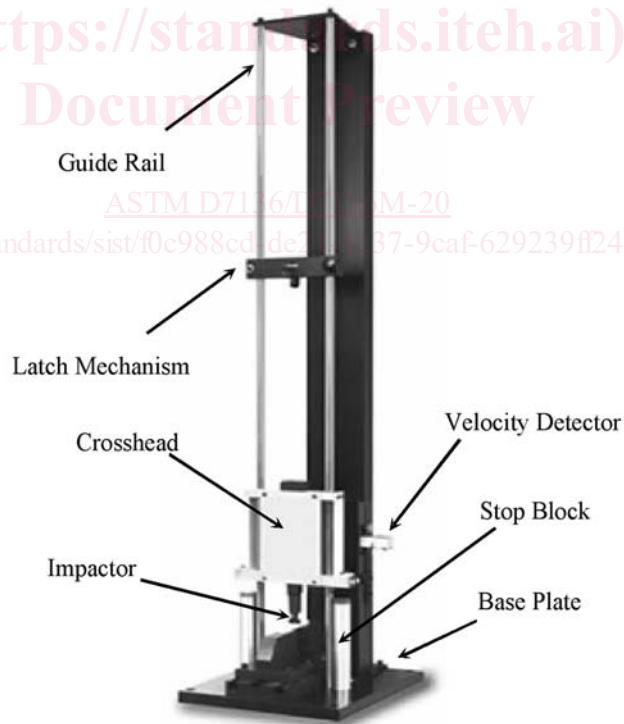

FIG. 6 Impact Device with Double Column Impactor Guide Mechanism

understood that the damage resistance of a composite structure is highly dependent upon several factors, including geometry, thickness, stiffness, mass, support conditions, and so forth. Significant differences in the relationships between impact

force/energy and the resultant damage state can result due to differences in these parameters. For example, properties obtained using this test method would more likely reflect the damage resistance characteristics of an unstiffened monolithic

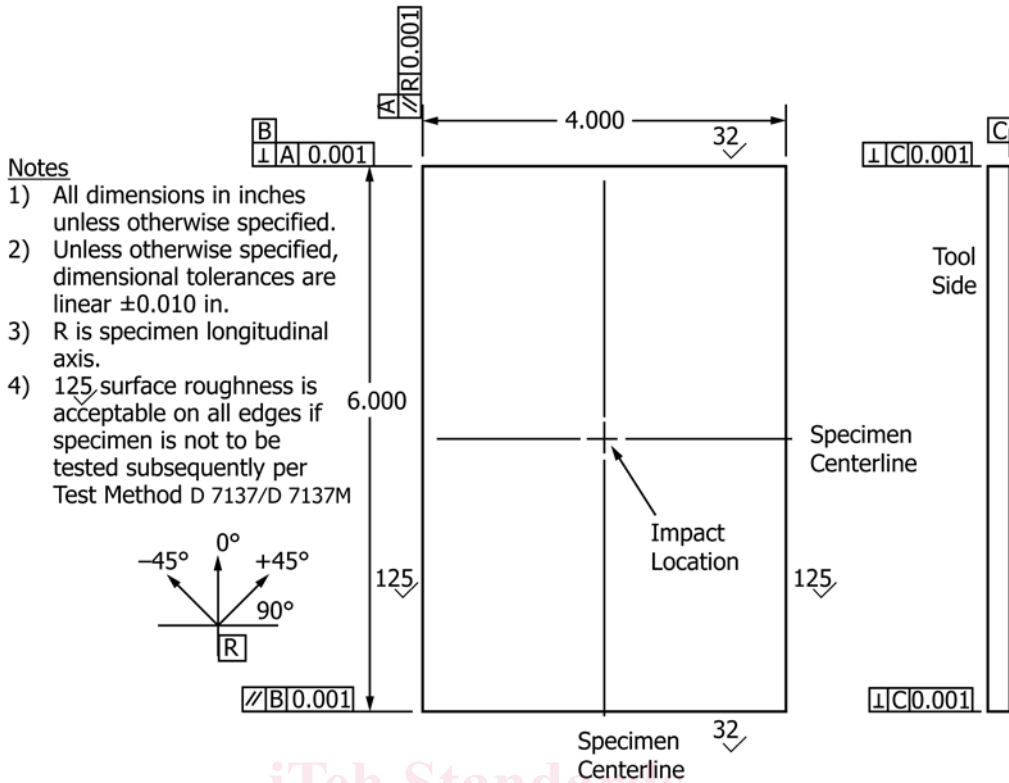

FIG. 7 Drop-Weight Impact Test Specimen (Inch-Pound Version)

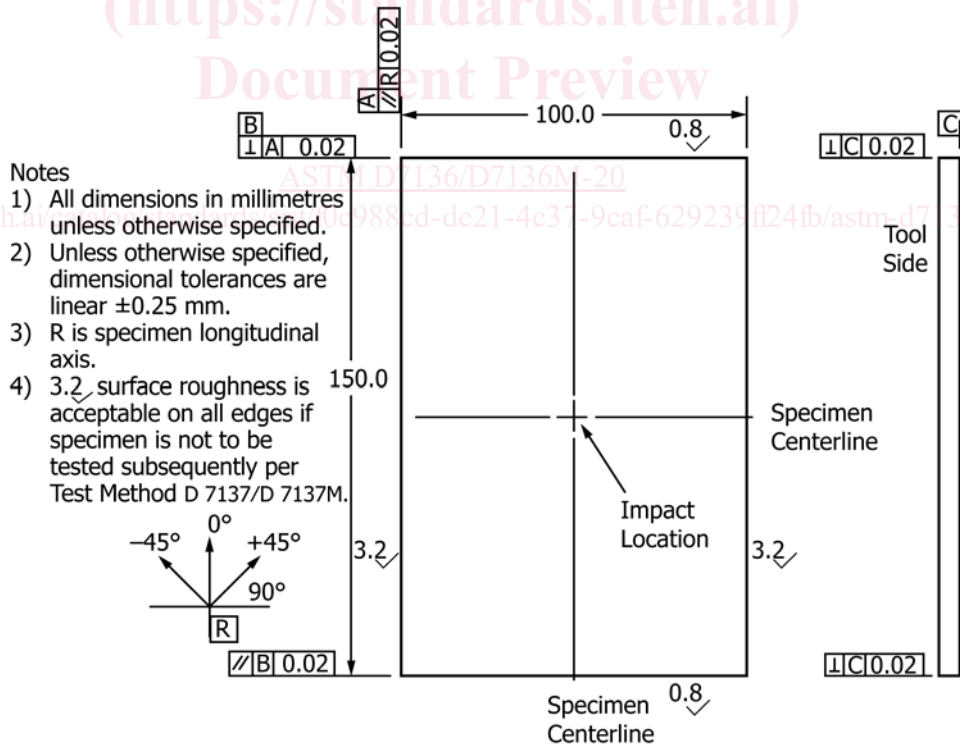

FIG. 8 Drop-Weight Impact Test Specimen (SI Version)

skin or web than that of a skin attached to substructure which resists out-of-plane deformation. Similarly, test specimen properties would be expected to be similar to those of a panel with

equivalent length and width dimensions, in comparison to those of a panel significantly larger than the test specimen,

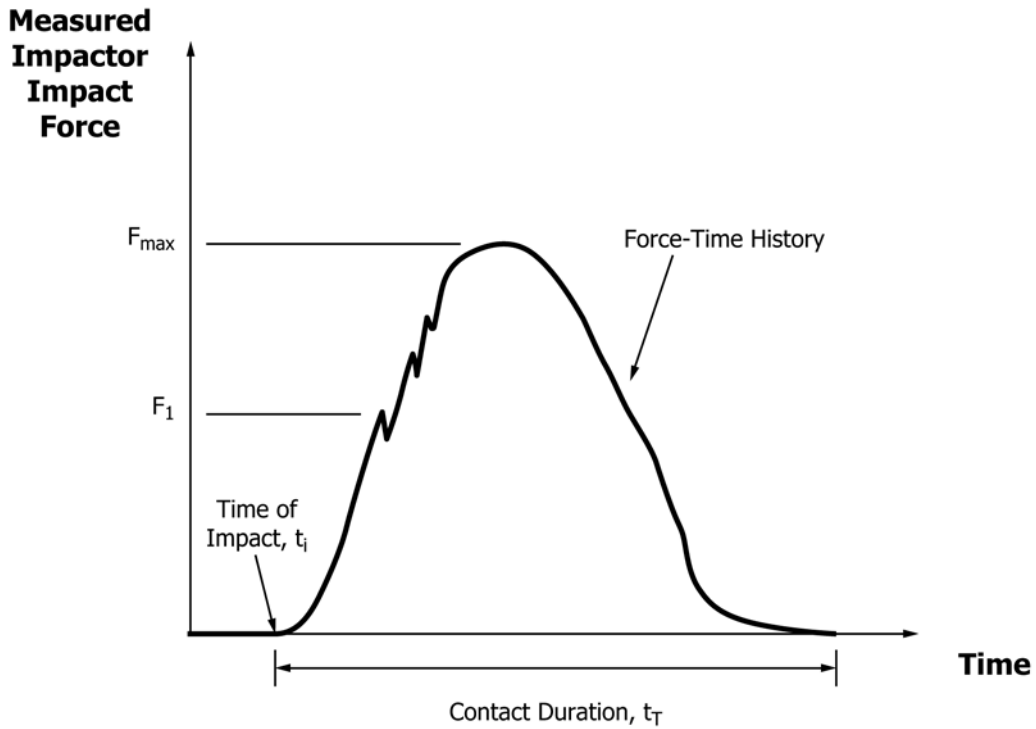

FIG. 9 Representative Impactor Force versus Time History

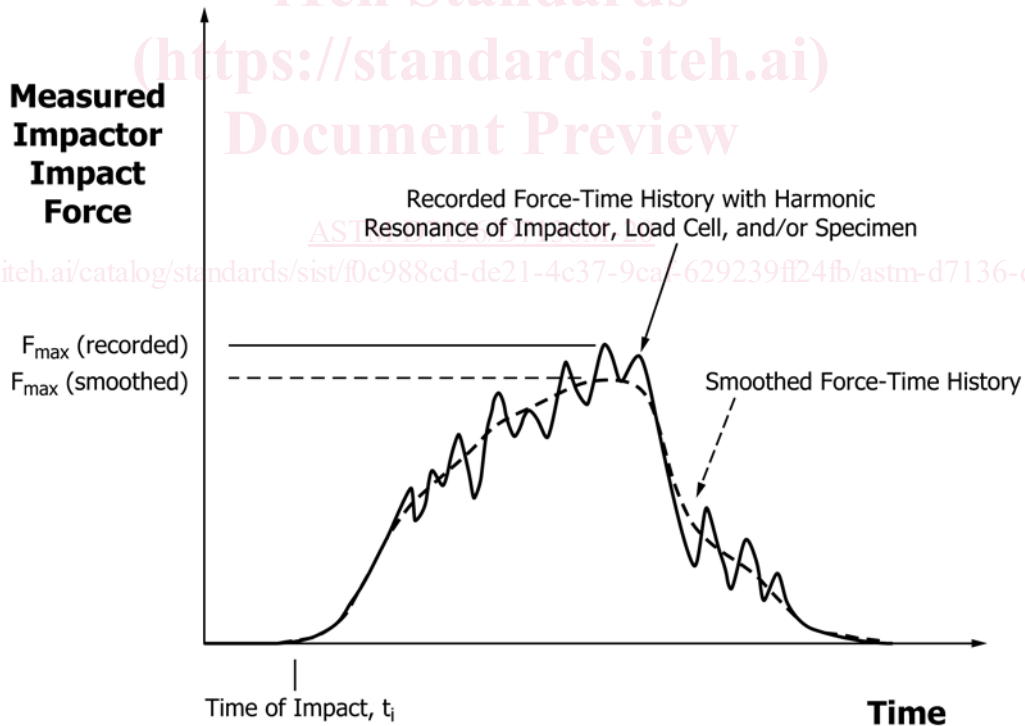

FIG. 10 Impactor Force versus Time History with Harmonic Resonance

which tends to divert a greater proportion of the impact energy into elastic deformation.

5.4 The standard impactor geometry has a blunt, hemispherical striker tip. Historically, for the standard laminate configuration and impact energy, this impactor geometry has

generated a larger amount of internal damage for a given amount of external damage, when compared with that observed for similar impacts using sharp striker tips. Alternative impactors may be appropriate depending upon the damage resistance characteristics being examined. For example, the use of sharp