



Designation: ~~D3336 – 20a~~ D3336 – 20b

Standard Test Method for Life of Lubricating Greases in Ball Bearings at Elevated Temperatures¹

This standard is issued under the fixed designation D3336; the number immediately following the designation indicates the year of original adoption or, in the case of revision, the year of last revision. A number in parentheses indicates the year of last reappraisal. A superscript epsilon (ϵ) indicates an editorial change since the last revision or reappraisal.

This standard has been approved for use by agencies of the U.S. Department of Defense.

1. Scope*

1.1 This test method covers the evaluation of the performance of lubricating greases in ball bearings operating under light loads at high speeds and elevated temperatures.

1.2 The values stated in SI units are to be regarded as standard.

1.2.1 *Exception*—The values given in parentheses are mathematical conversions to inch-pound units that are provided for information only and are not considered standard.

1.3 *This standard does not purport to address all of the safety concerns, if any, associated with its use. It is the responsibility of the user of this standard to establish appropriate safety, health, and environmental practices and determine the applicability of regulatory limitations prior to use.* For specific warning statements, see 8.1.

1.4 *This international standard was developed in accordance with internationally recognized principles on standardization established in the Decision on Principles for the Development of International Standards, Guides and Recommendations issued by the World Trade Organization Technical Barriers to Trade (TBT) Committee.*

2. Referenced Documents

2.1 *ASTM Standards:*²

A600 Specification for Tool Steel High Speed

2.2 *ABMA Standard:*³

Standard 4, Tolerance Definitions and Gaging Practices for Ball and Roller Bearings

3. Summary of Test Method

3.1 A grease lubricated SAE No. 204 size ball bearing is rotated at 10 000 r/min under light load at a specified elevated temperature. Tests are continued until failure or completion of a specified number of hours of running time.

¹ This test method is under the jurisdiction of ASTM Committee D02 on Petroleum Products, Liquid Fuels, and Lubricants and is the direct responsibility of Subcommittee D02.G0.05 on Functional Tests - Temperature.

Current edition approved July 1, 2020/Nov. 1, 2020. Published July 2020/November 2020. Originally approved in 1975. Last previous edition approved in 2020 as ~~D3336 – 20~~ D3336 – 20a. DOI: 10.1520/D3336-20A-10.1520/D3336-20B.

² For referenced ASTM standards, visit the ASTM website, www.astm.org, or contact ASTM Customer Service at service@astm.org. For *Annual Book of ASTM Standards* volume information, refer to the standard's Document Summary page on the ASTM website.

³ Available from American Bearing Manufacturers Assoc., 2025 M St., NW, Ste 800, Washington, DC 20036.

*A Summary of Changes section appears at the end of this standard

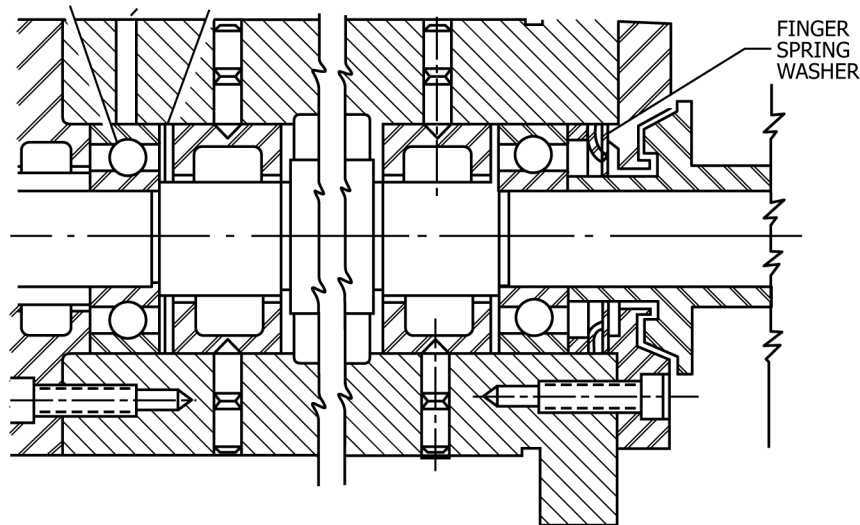

FIG. 1 Test Spindle (Both Bearings Floating)

4. Significance and Use

4.1 This test method can be used to evaluate the ability of grease to provide adequate lubrication for extended periods of ball bearings operating under light loads at high speeds and elevated temperatures.

5. Apparatus^{4,5}

5.1 *Test Spindle*⁶ (see Figs. 1-4), capable of operating at speeds of 10 000 r/min and temperatures as high as 371 °C (700 °F). The test bearing seat dimension shall be 19.99 mm to 20.00 mm (0.7870 in. to 0.7874 in.). For spindles having the test bearing and the support bearing in the same housing (CRC Type, Figs. 1-3 Fig. 1, Fig. 2, and Fig. 4) the internal construction of the spindle shall be such that the outboard support bearing, or both bearings are free to float axially in the housing. In designs where both bearings are free to float, the spindle shaft shall have a 0.508 mm to 0.762 mm (0.020 in. to 0.030 in.) free axial movement or end play. The outboard bearing seat dimension should be 19.99 mm to 20.00 mm (0.7870 in. to 0.7874 in.).

5.1.1 The test unit design should be such that a finger spring washer (Fig. 1) and Fig. 2) should be such a Z-Spring washer (Fig. 2 that a finger spring washer) produces a 22 N to 67 N (5 lbf to 15 lbf) thrust load on the floating outboard support bearing.^{7,5}

5.2 Bearing Housing:

5.2.1 *For CRC Type Spindles*—The bearing housing diameter shall be 47.005 mm to 47.021 mm (1.8506 in. to 1.8512 in.) to give proper bearing mounting. Construction shall be such that the test bearing is equipped with flush spacers or shields to confine the grease to the bearing. The spacers or shields shall have a clearance between the inside diameter and the shaft of 0.127 mm to 0.178 mm (0.005 in. to 0.007 in.) per side.

NOTE 1—This type of spindle is described in CRC Research Technique for the Determination of Performance Characteristics of Lubricating Grease in Antifriction Bearings at Elevated Temperature (CRC Designations L-35-54 and CRC L-35-62).

5.2.2 *For Navy Type Spindles (Test Bearing Mounted Outside Spindle Housing)*—The bearing housing shall be constructed of material similar to that of the test bearing and shall be tempered to retain dimensional stability at temperatures up to 371 °C (700 °F). Internal diameter shall be 47.005 mm to 47.021 mm (1.8506 in. to 1.8512 in.). The housing cover shall be flush fitting to confine the grease to the bearing. Provision shall be made for insertion in the housing of one or two small thermocouples which

⁴ Complete apparatus is available from Falex Corp., 1020 Airpark Dr., Sugar Grove, IL 60554.

⁵ If you are aware of alternative suppliers, please provide this information to ASTM International Headquarters. Your comments will receive careful consideration at a meeting of the responsible technical committee,¹ which you may attend.

⁶ Pope Machinery Corporation Grease Test Spindles No. P-1911 or P-6301A-HT (Fig. 1) and No. P-7605-B (Fig. 2); and Falex Corp. spindles of the type shown in Fig. 1 and Fig. 23 have been found satisfactory for this purpose.

⁷ The sole source of supply of the apparatus known to the committee at this time is Falex Part No. 643-187-070, Falex Corp. 1020 Airpark Dr., Sugar Grove, IL 60554.

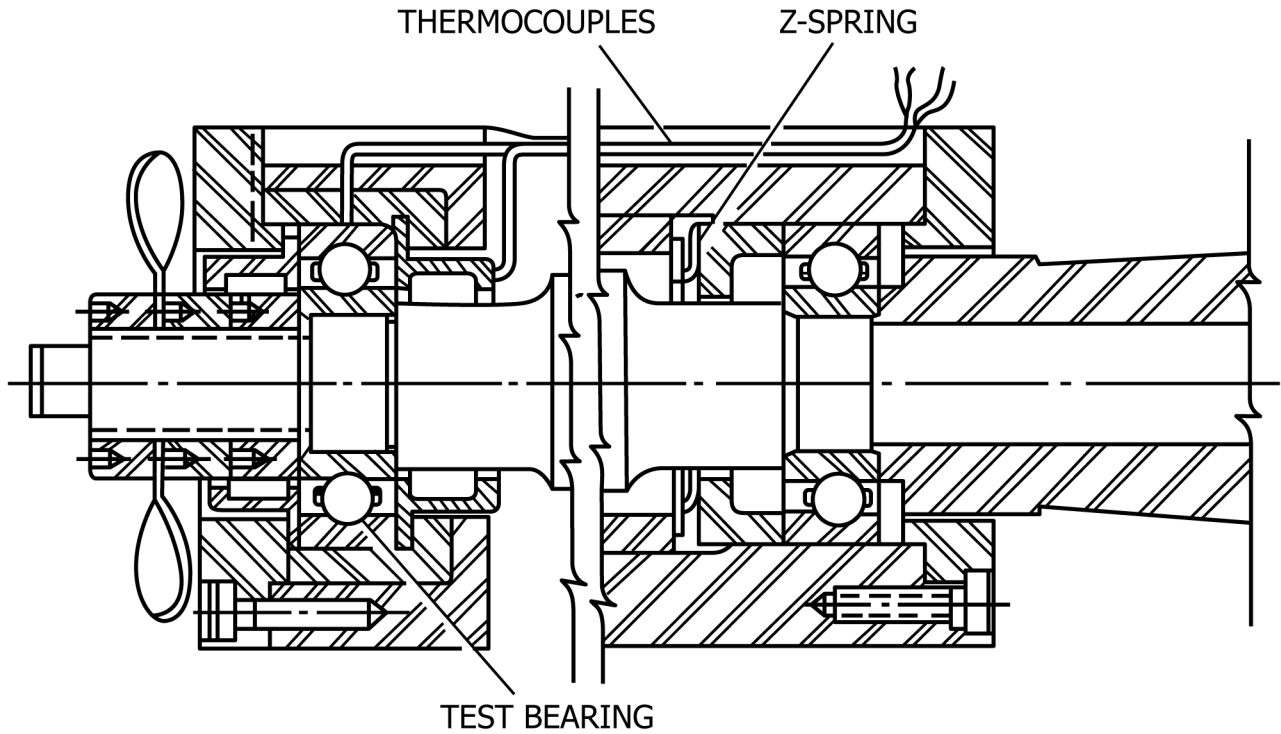

FIG. 2 Test Spindle (Test Bearing Held)

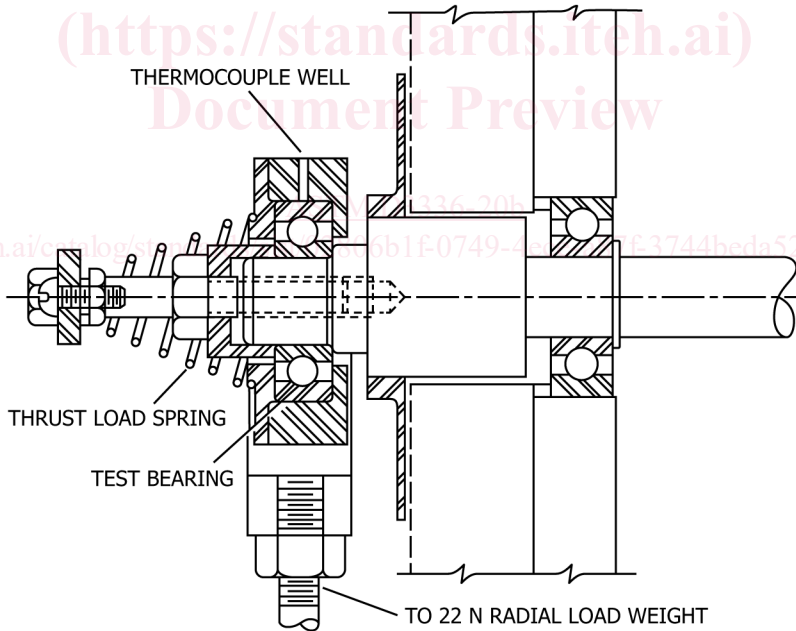

FIG. 3 Test Spindle (with Radial Load)

shall lightly press on and be in continual contact with the outer race of the test bearing. The housing shall be fitted with lugs to accommodate a yoke and added weight so that a radial load may be applied to the test bearing. A thrust load of $22\text{ N} \pm 2\text{ N}$ ($5\text{ lbf} \pm 0.55\text{ lbf}$) shall be applied to the outer race of the bearing by means of a helical spring calibrated at room temperature.

5.3 *Motor Drive Assembly*—Spindle bracket and constant belt tension motor drive assembly capable of providing spindle speeds up to $10\,000\text{ r/min} \pm 200\text{ r/min}$ by means of an endless belt. The motor shall be mounted so that a belt tension of approximately 67 N (15 lbf) can be maintained on the test spindle pulley.

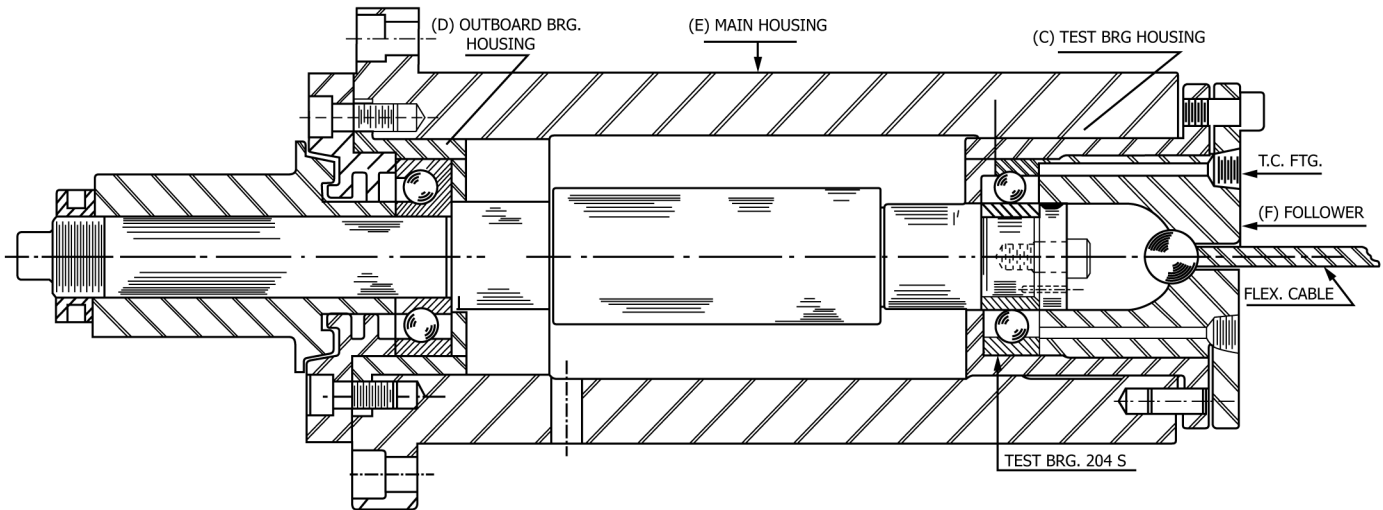

FIG. 4 Test Spindle Thrust Load Design

5.4 *Oven*, removable, capable of producing a test temperature of 371 °C (700 °F) within 1½ h.

5.5 *Control Equipment*:

5.5.1 The temperature at the outside diameter of the test bearing shall be maintained within 3 °C (5 °F) of the specified test temperature. The temperature control equipment shall be adequate to maintain the temperature at the outer race of the test bearing within the limits specified by control of the oven temperature. The oven temperature shall be controlled by means of a thermocouple placed in the oven cavity.

5.5.2 Suitable equipment such as adjustable reset relay and overload device for shutting off oven heaters and drive motor and other accessory equipment (timer, recorder, etc.) shall be provided. Oven temperature as well as bearing temperature should be recorded.

6. **Materials**

6.1 *Test Bearing, General Requirements*—ISO 6204 (SAE No. 204) size, manufactured to ABEC-3 quality. See **Annex A1**, which describes ABMA’s standard method of measuring radial internal clearances of ball bearings. Support bearings of CRC Type spindles shall be identical to the test bearings.

6.1.1 *Lower Temperature Bearing*—For testing at temperatures of 149 °C (300 °F) and below, a size 6204 bearing (PCN 12-433360-12) has been found satisfactory. This bearing is fabricated from AISI 52100 steel, with a retainer fabricated from AISI C1010 steel and with an internal clearance range of 0.021 mm to 0.028 mm (0.0008 in. to 0.0011 in.).⁸

6.1.2 *Higher Temperature Bearing*—For testing at temperatures above 149 °C (300 °F), the bearing shall be fabricated from heat-resistant steel and equipped with a ball retainer fabricated from suitable material, both capable of withstanding temperatures as high as 371 °C (700 °F). Bearings fabricated from 18-4-1 high speed or M-50 (Specification **A600**) tool steel with retainers fabricated from heat-treated silver-plated beryllium copper⁹ have been found satisfactory for this purpose. The bearing shall have a radial clearance of from 0.025 mm to 0.031 mm (0.0010 in. to 0.0012 in.).

6.2 *ASTM n-Heptane*.¹⁰

6.3 *Mineral Spirits*, reagent grade.

⁸ Supporting data have been filed at ASTM International Headquarters and may be obtained by requesting Research Report RR:D02-1272. Contact ASTM Customer Service at service@astm.org.

⁹ The sole source of supply of the apparatus known to the committee at this time is Bearing MRC204S17, SKF Bearings, www.skf.com. If you are aware of alternative suppliers, please provide this information to ASTM International Headquarters. Your comments will receive careful consideration at a meeting of the responsible technical committee,¹ which you may attend.

¹⁰ Described in 1996 *Annual Book of ASTM Standards*, Vol 05.04, Annex 2, Section A2.7 on Reference Materials.

7. Test Conditions

7.1 *Temperature*—As specified up to 371 °C (700 °F).

7.2 *Speed*—10 000 r/min \pm 200 r/min.

7.3 *Test Cycle*:

7.3.1 Twenty-one and one-half hours running at temperatures of 149 °C (300 °F) and below—2½ h shutdown without applied heat. Shutdown refers to the shutdown of both the spindle motor drive and oven.

7.3.2 Twenty hours running at temperatures of above 149 °C (300 °F)—4 h shutdown without applied heat. Shutdown refers to the shutdown of both the spindle motor drive and oven.

8. Preparation of Apparatus

8.1 Just prior to lubrication for test, clean the test bearing by rotating it in warm (approximately 50 °C (120 °F)) mineral spirits, reagent grade (**Warning**—Flammable. Harmful if inhaled) followed by two successive washes of ASTM *n*-heptane (**Warning**—Combustible. Vapor harmful) and flash dry in an oven at 71 °C (160 °F). Cool the bearing to room temperature.

8.2 Pack the bearing by hand so that it contains a weighed quantity of grease equivalent to 3.2 cm³ \pm 0.1 cm³. The grease can also be measured by volume and applied to the bearing by means of a syringe. The grease shall be worked uniformly into both sides of the bearings, using a narrow blade spatula, making sure that the grease does not extend beyond the facet of the races. For CRC Type spindles the support bearing shall be packed full.

8.3 Assemble the test bearing, support bearing, and Z-spring (see Fig. 1 and Fig. 2) on the spindle and fix the thermocouples into position so that it is in contact with the outer race of the test bearing (CRC Type spindles). For tests at 232 °C (450 °F) and above, replace the finger spring washer for each test. For Navy Type spindles insert the test bearing into the housing and press the bearing onto the spindle by application of a light force on the inner race. Place the cover plate in position, fix the thermocouples into position, and apply the radial and thrust loads.

9. Procedure

ASTM D3336-20b

<https://standards.iteh.ai/catalog/standards/sist/02806b1f-0749-4ece-a87f-3744beda5218/astm-d3336-20b>

9.1 Rotate the bearing by hand for approximately 100 revolutions in each direction at a speed not exceeding 200 r/min. Start the drive motor and heater simultaneously and adjust the temperature controller to raise the bearing to test temperature within 1½ h. After 2 h of test operation at speed and control temperature, measure the temperature of the outer race of the test bearing. Adjust the controller such that the outer race of the test bearing is at test temperature for the grease. Record test hours (running time), control temperature, and outer-race temperature of the bearing at least every 24 h. Unless automatic controls are employed, a 72 h shutdown (without applied heat) over the weekend, shall be followed. For Navy Type spindles the oven door shall remain closed during periods of shutdown.

NOTE 2—Once satisfactory thermal stability has been established with the test bearing, no further manual adjustment is normally necessary. However, minor adjustments may be made to accommodate changing conditions of voltage, ambient temperatures, etc.

9.2 Continue the test until failure or completion of a specified number of known running times.

10. Results

10.1 The lubricant is considered to have failed when any one of the following conditions occurs:

10.1.1 Spindle input power increases to a value of 300 % above the steady state condition at test temperature.

10.1.2 An increase in temperature at the test bearing of 15 °C (27 °F) over the test temperature during any portion of a cycle. Ignore any temperature rise that takes place within 30 min after reaching test temperature after daily start-up.

10.1.3 There is loading of the test bearing or belt slippage at start up or during the test cycle.