



Standard Specification for Taper Pipe Threads 60° for Thermoplastic Pipe and Fittings¹

This standard is issued under the fixed designation F1498; the number immediately following the designation indicates the year of original adoption or, in the case of revision, the year of last revision. A number in parentheses indicates the year of last reapproval. A superscript epsilon (ϵ) indicates an editorial change since the last revision or reapproval.

1. Scope*

1.1 This specification establishes requirements for dimensions and gaging of taper pipe threads used on threaded plastic pipe and fittings.

1.2 Threads meeting this specification shall only be used on those plastic materials deemed suitable by the manufacturer.

1.3 Specialty threads or threads not requiring a leak-tight joint are not covered in this specification.

NOTE 1—The terms “wrench makeup” and “wrench tight” are standard terminology for tightness and do not imply using a pipe wrench or other tools which would damage plastic pipe and fittings. The terms “hand-tight” and “hand-tight engagement” refer only to thread gaging (not pipe and fitting connections) and is the definition of the L_1 gage length.

1.4 *Thread Designations*—The type of pipe threads included in this specification are designated by specifying in sequence the nominal pipe size, number of threads per inch, and the thread series symbols as follows in accordance with ANSI/ASME B 1.20.1: $\frac{3}{8}$ -18 NPT. For left-hand threads add LH to the end of the designation, otherwise right-hand threads will be understood. For example: $\frac{3}{8}$ -18 NPT-LH.

1.4.1 Each of these letters in the symbol has a definite significance as follows:

N = National (American Standard)
P = Pipe
T = Taper

1.5 The values stated in inch-pound units are to be regarded as the standard. No other units of measurement are included in this standard.

1.6 *This standard does not purport to address all of the safety concerns, if any, associated with its use. It is the responsibility of the user of this standard to establish appropriate safety, health, and environmental practices and determine the applicability of regulatory limitations prior to use.* For specific precautionary statements, see 7.2.1 and 8.3.

1.7 *This international standard was developed in accordance with internationally recognized principles on standardization established in the Decision on Principles for the*

Development of International Standards, Guides and Recommendations issued by the World Trade Organization Technical Barriers to Trade (TBT) Committee.

2. Referenced Documents

2.1 *ASTM Standards:*²

D1600 *Terminology for Abbreviated Terms Relating to Plastics*

E177 *Practice for Use of the Terms Precision and Bias in ASTM Test Methods*

F412 *Terminology Relating to Plastic Piping Systems*

2.2 *ASME Standards:*³

B 1.20.1 *Pipe Threads, General Purpose (inch)*

B 1.7 *Nomenclature, Definitions and Letter Symbols for Screw Threads*³

B 47.1 *Gage Blanks*

3. Terminology

3.1 Terminology is in accordance with Terminology F412 and abbreviations are in accordance with Terminology D1600, unless otherwise indicated.

3.2 Nomenclature, definitions, and letter symbols for screw threads are in accordance with ASME/ANSI B 1.7.

4. American National Standard Taper Pipe Thread Form

4.1 *Thread Form*—The form of thread profile specified in this specification shall be known as the American National Standard Taper Pipe Thread Form. The relations as specified herein, for form of thread and general notations are shown in Fig. 1.

4.2 *Angle of Thread*—The angle between the sides of the thread is 60° when measured in an axial plane. The line bisecting this angle is perpendicular to the axis.

4.3 *Truncation and Thread Height*—The height of the sharp V thread, H , is as follows:

² For referenced ASTM standards, visit the ASTM website, www.astm.org, or contact ASTM Customer Service at service@astm.org. For *Annual Book of ASTM Standards* volume information, refer to the standard's Document Summary page on the ASTM website.

³ Available from American Society of Mechanical Engineers (ASME), ASME International Headquarters, Two Park Ave., New York, NY 10016-5990, http://www.asme.org.

¹ This specification is under the jurisdiction of ASTM Committee F17 on Plastic Piping Systems and is the direct responsibility of Subcommittee F17.10 on Fittings.

Current edition approved Nov. 1, 2020. Published November 2020. Originally approved in 1994. Last previous edition approved in 2012 as F1498 – 12^{e1}. DOI: 10.1520/F1498-08R20

*A Summary of Changes section appears at the end of this standard

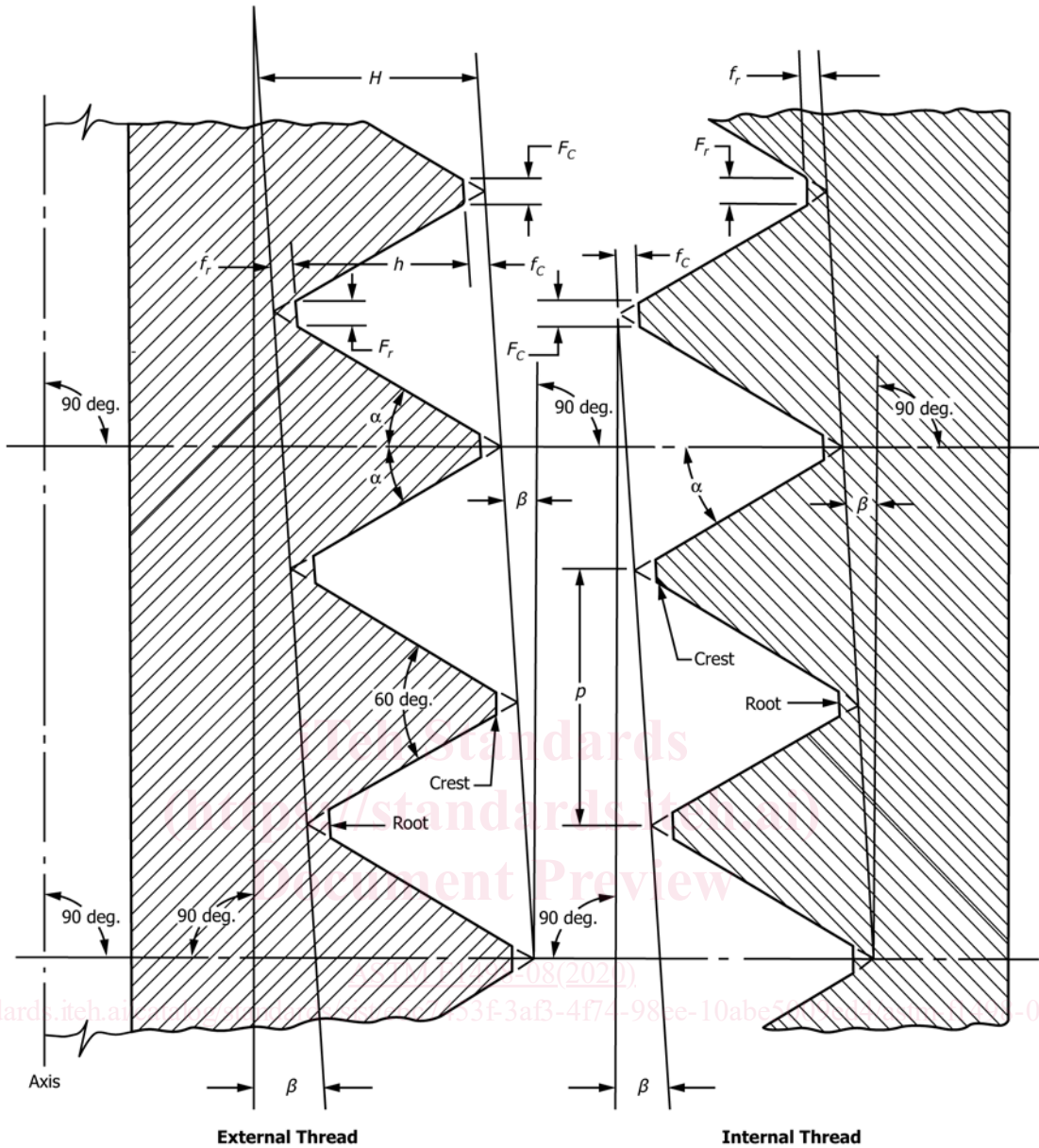

$H = 0.866025p = \text{height of } 60^\circ \text{ sharp V thread}$
 $h = 0.800000p = \text{height of thread on product}$
 $p = 1/n = \text{pitch (measured parallel to axis)}$
 $n = \text{number of threads per inch}$
 $\alpha = 30^\circ = \text{thread flank angle}$

$\beta = 1^\circ 47 \text{ min.} = \text{thread taper angle for } 1/16 \text{ taper}$
 $f_c = \text{depth of truncation at crest}$
 $f_r = \text{depth of truncation at root}$
 $F_c = \text{width of flat at crest}$
 $F_r = \text{width of flat at root}$

NOTE 1—For a symmetrical straight screw thread, $H = \cot \alpha / 2n$. For a symmetrical taper screw thread, $H = (\cot \alpha - \tan^2 \beta \tan \alpha) / 2n$, so that the exact value for an American National Standard Taper Pipe Thread is $H = 0.865743p$ as against $H = 0.866025p$, the value given above. For an 8-pitch thread, which is the coarsest standard taper pipe thread pitch, the corresponding values of H are 0.108218 and 0.108253 respectively, the difference being 0.000035 in. This difference being too small to be significant, the value of $H = 0.866025p$ continues in use for threads of 0.750 in., or less, taper/ft on the diameter.

FIG. 1 Basic Form of American National Standard Taper Pipe Thread

$$H = 0.866025p = 0.866025/n \quad (1)$$

$$h = 0.800p = 0.800/n \quad (2)$$

where:

p = pitch of thread, and
 n = threads per inch.

4.3.1 The basic maximum height of the truncated thread, h (see Fig. 1) is based on factors entering into the manufacture of cutting tools and the making of tight joints.

The crest and root of pipe threads are truncated a minimum of $0.033p$. Maximum truncation for the crest and root of these pipe threads is in Table 1. The crests and roots of the external and internal threads may be truncated either parallel to the pitch line or parallel to the axis. The sketches in Tables 2-6 give a sectional view of this standard thread form, which represents

TABLE 1 Limits on Crest and Root Truncation of American National Standard External and Internal Taper Pipe Threads, NPT^A

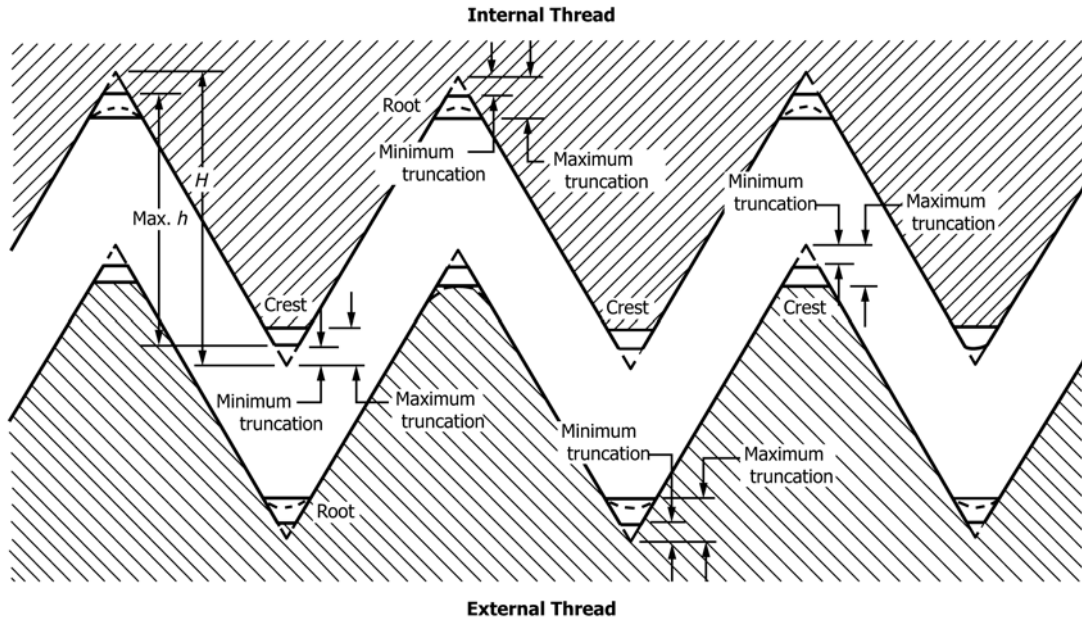

Threads/ in. (n)	Height of Sharp V Thread (H)	Height of Thread (h)		Truncation (f)					Equivalent Width of Flat (F)				
				Min		Max		Tolerance	Min		Max		Tolerance
				Max	Min	Formula	Inch		Formula	Inch	Formula	Inch	
1	2	3	4	5	6	7	8	9	10	11	12	13	14
27	0.03208	0.02963	0.02496	0.033p	0.0012	0.096p	0.0036	0.0024	0.038p	0.0014	0.111p	0.0041	0.0027
18	0.04811	0.04444	0.03833	0.033p	0.0018	0.088p	0.0049	0.0031	0.038p	0.0021	0.102p	0.0057	0.0036
14	0.06186	0.05714	0.05071	0.033p	0.0024	0.078p	0.0056	0.0032	0.038p	0.0027	0.090p	0.0064	0.0037
11.5	0.07531	0.06957	0.06261	0.033p	0.0029	0.073p	0.0063	0.0034	0.038p	0.0033	0.084p	0.0073	0.0040
8	0.10825	0.10000	0.09275	0.033p	0.0041	0.062p	0.0078	0.0037	0.038p	0.0048	0.072p	0.0090	0.0042

^A The basic dimensions of the American National Standard Taper Pipe Thread are given in inches to four and five decimal places. While this implies a greater degree of precision than is ordinarily attained, these dimensions are so expressed for the purpose of eliminating errors in computations.

TABLE 2 ABS, CPVC, and PVC Reference Information

Nominal Pipe Size, in.	Minimum Wall-Thickness, in.		Minimum Hub-Diameter, in.	
	Schedule 80 Pipe	DWV	Schedule 40 and DWV	Schedule 80
1/8	0.095	...	0.526	0.645
1/4	0.119	...	0.672	0.840
3/8	0.126	...	0.821	1.000
1/2	0.147	...	0.998	1.280
3/4	0.154	...	1.221	1.450
1	0.179	...	1.504	1.810
1 1/4	0.191	0.100	1.871	2.200
1 1/2	0.200	0.088	2.127	2.450
2	0.218	0.066	2.634	3.000
2 1/2	0.276	...	3.170	3.560
3	0.300	0.086	3.841	4.250
3 1/2	0.318	...	4.374	...
4	0.337	0.104	4.907	5.350
5	0.375	...	6.039	...
6	0.432	...	7.203	7.625
8	0.500	...	9.320	...
10	0.593	...	11.614	...
12	0.687	...	13.786	...

the truncated thread form by a straight line. However, when closely examined, the crests and roots of molded pipe threads appear slightly rounded.

4.4 Thread Starts—Machined—Feathered starts are produced by a 45° chamfer on the first thread when the thread is

cut with a tap or die. The depth of chamfer shall be from 3/4 to 1 1/4 thread deep (see Fig. 2(a)). Feathered starts are prone to crossing and mutilation and shall not be molded.

4.5 Thread Starts—Molded—Internal and external molded threads shall begin with a taper or blunt start. A pilot shall be provided from the face of the fitting and at the entering end of the external threads; it shall have a length to the start (flank) of the first thread, equal to 1/2 to 3/4 the width of the thread pitch, 1 to 1 1/4 thread pitch to the centerline. (Thread pitch equals one turn; see Fig. 2(b) and Fig. 2(c).) The pilot shall be included in the measurement of the thread length.

4.5.1 Taper starts on the first thread are formed by the thread rising from the minimum to maximum diameter while maintaining the 60° thread profile (see Fig. 2(b)). The length of rise shall not exceed 1/8 turn (45°).

4.5.2 Blunt starts on the first thread are formed by the thread rising from the minimum to maximum diameter while maintaining the 60° thread profile (see Fig. 2(c)). The length of rise shall not be greater than twice the thread height. The blunt start is the preferred thread start.

4.6 Plastic Threads—General—The minimum wall thickness (see Table 2) for the threaded portion of a plastic pipe or fitting depends upon the material and the application. For pressure rated pipe, reduce the pressure rating for threaded pipe

TABLE 3 Basic Dimensions of American National Standard Taper Thread, NPT^A

NOTE 1—Wrench makeup modified for plastic.

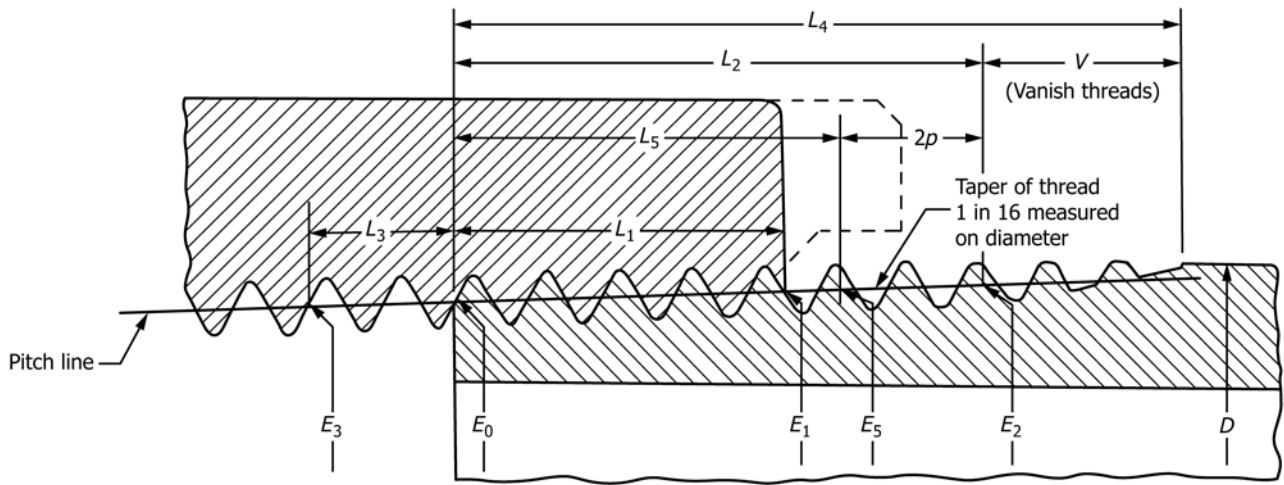

Nominal Pipe Size, in.	Outside Diameter of Pipe (D)	Threads/in. (n)	Pitch of Thread (P)	Pitch Diameter at Beginning of External Thread (E ₀)	Hand-tight Gage Engagement			Effective Thread, External		
					Length ^B (L ₁)		Diameter ^C (E ₁)	Length ^D (L ₂)		Diameter (E ₂)
					Inch	Threads		Inch	Threads	
1	2	3	4	5	6	7	8	9	10	11
1/16	0.3125	27	0.03704	0.27118	0.160	4.32	0.28118	0.2611	7.05	0.28750
1/8	0.405	27	0.03704	0.36351	0.1615	4.36	0.37360	0.2639	7.12	0.38000
1/4	0.540	18	0.05556	0.47739	0.2278	4.10	0.49163	0.4018	7.23	0.50250
3/8	0.675	18	0.05556	0.61201	0.240	4.32	0.62701	0.4078	7.34	0.63750
1/2	0.840	14	0.07143	0.75843	0.320	4.48	0.77843	0.5337	7.47	0.79179
3/4	1.050	14	0.07143	0.96768	0.339	4.75	0.98887	0.5457	7.64	1.00179
1	1.315	11.5	0.08696	1.21363	0.400	4.60	1.23863	0.6828	7.85	1.25630
1 1/4	1.660	11.5	0.08696	1.55713	0.420	4.83	1.58338	0.7068	8.13	1.60130
1 1/2	1.900	11.5	0.08696	1.79609	0.420	4.83	1.82234	0.7235	8.32	1.84130
2	2.375	11.5	0.08696	2.26902	0.436	5.01	2.29627	0.7565	8.70	2.31630
2 1/2	2.875	8	0.12500	2.71953	0.682	5.46	2.76216	1.1375	9.10	2.79062
3	3.500	8	0.12500	3.34062	0.766	6.13	3.38850	1.2000	9.60	3.41562
3 1/2	4.000	8	0.12500	3.83750	0.821	6.57	3.88881	1.2500	10.00	3.91562
4	4.500	8	0.12500	4.33438	0.844	6.75	4.38712	1.3000	10.40	4.41562
5	5.563	8	0.12500	5.39073	0.937	7.50	5.44929	1.4063	11.25	5.47862
6	6.625	8	0.12500	6.44609	0.958	7.66	6.50597	1.5125	12.10	6.54062
8	8.625	8	0.12500	8.43359	1.063	8.50	8.50003	1.7125	13.70	8.54062
10	10.750	8	0.12500	10.54531	1.210	9.68	10.62094	1.9250	15.40	10.66562
12	12.750	8	0.12500	12.53281	1.360	10.88	12.61781	2.1250	17.00	12.66562

^A The basic dimensions of the American National Standard Taper Pipe Thread are given in inches to four or five decimal places. While this implies a greater degree of precision than is ordinarily attained, these dimensions are the basis of gage dimensions and are so expressed for the purpose of eliminating errors in computations.

^B Also length of thin ring gage and length from gaging notch to small end of plug gage.

^C Also pitch diameter at gaging notch (hand-tight plane).

^D Also length of plug gage.

by one-half (50 %) that of unthreaded pipe. Some pressure rated pipe materials (for example, PP and PE) are not recommended for threaded applications. If the wall thickness is not specified in a pipe or fitting standard, the manufacturer must determine the appropriate wall thickness.

4.7 Sealing—Where pressure-tight or leak-tight non-pressure joints are required, it is intended that taper pipe threads conforming to this specification be made up with PTFE (polytetrafluoroethylene or equivalent) tape or a chemically compatible a sealant-lubricant. Conventional pipe-thread compounds, putty, linseed oil-base products, and unknown mixtures shall not be used.

NOTE 2—Some TFE-fluorocarbon-paste compounds, even though they

are recommended by the manufacturer, may not be compatible with some plastics.

4.8 Thread Tightness—Wrench Makeup—Some lubricants (PTFE pastes, silicones, etc.) will provide added lubricity, which can result in more finger-tight engagement than with sealants. The maximum recommended tightness is two turns past finger tight for both internal and external threads. Over tightening of internal threads will produce hoop stresses greater than plastic can withstand, resulting in split fittings.

NOTE 3—When assembling metal and plastic threads, the preferred method is plastic external (male) threads to metal internal (female) threads. Cyclic heating and cooling may result in dripping leaks.

NOTE 4—When PTFE tape is used to seal the threads, wrap the external threads with 2 to 3 layers.

TABLE 3 Basic Dimensions of American National Standard Taper Thread, NPT (continued)

Nominal Pipe Size, in.	Length, L_1 Plane to L_2 Plane External Thread ($L_2 - L_1$)		Wrench Makeup Length for Internal Thread ^A				Vanish Thread (V)		Overall Length External Thread (L_4)	Nominal Complete External Thread ^C		Height of Thread (h)	Increase in Diameter per Thread (0.0625/n)	Basic Minor Diameter at Small End of Pipe (K_0)
	Inch	Thread	Length (L_3)		Diameter (E_3)	Inch	Thread	Length (L_5)		Diameter (E_5)				
			Inch	Thread										
1	12	13	14	15	16	17	18	19	20	21	22	23	24	
1/16	0.1011	2.73	0.0741	2	0.26656	0.1285	3.47	0.3896	0.1870	0.28287	0.02963	0.00231	0.2416	
1/8	0.1024	2.76	0.0741	2	0.35889	0.1285	3.47	0.3924	0.1898	0.37537	0.02963	0.00231	0.3339	
1/4	0.1740	3.13	0.1111	2	0.47045	0.1928	3.47	0.5946	0.2907	0.49556	0.04444	0.00347	0.4329	
3/8	0.1678	3.02	0.1111	2	0.60507	0.1928	3.47	0.6006	0.2967	0.63056	0.04444	0.00347	0.5676	
1/2	0.2137	2.99	0.1429	2	0.74951	0.2478	3.47	0.7815	0.3909	0.78286	0.05714	0.00446	0.7013	
3/4	0.2067	2.89	0.1429	2	0.95876	0.2478	3.47	0.7935	0.4029	0.99286	0.05714	0.00446	0.9105	
1	0.2828	3.25	0.1739	2	1.20277	0.3017	3.47	0.9845	0.5089	1.24543	0.06957	0.00543	1.1441	
1 1/4	0.2868	3.30	0.1739	2	1.54627	0.3017	3.47	1.0085	0.5329	1.59043	0.06957	0.00543	1.4876	
1 1/2	0.3035	3.49	0.1739	2	1.78523	0.3017	3.47	1.0252	0.5496	1.83043	0.06957	0.00543	1.7265	
2	0.3205	3.69	0.1739	2	2.25816	0.3017	3.47	1.0582	0.5826	2.30543	0.06957	0.00543	2.1995	
2 1/2	0.4555	3.64	0.2500	2	2.70391	0.4337	3.47	1.5712	0.8875	2.77500	0.100000	0.00781	2.6195	
3	0.4340	3.47	0.2500	2	3.32500	0.4337	3.47	1.6337	0.9500	3.40000	0.100000	0.00781	3.2406	
3 1/2	0.4290	3.43	0.2500	2	3.82188	0.4337	3.47	1.6837	1.0000	3.90000	0.100000	0.00781	3.7375	
4	0.4560	3.65	0.2500	2	4.31875	0.4337	3.47	1.7337	1.0500	4.40000	0.100000	0.00781	4.2344	
5	0.4693	3.75	0.2500	2	5.37511	0.4337	3.47	1.8400	1.1563	5.46300	0.100000	0.00781	5.2907	
6	0.5545	4.44	0.2500	2	6.43047	0.4337	3.47	1.9462	1.2625	6.52500	0.100000	0.00781	6.3461	
8	0.6495	5.20	0.2500	2	8.41797	0.4337	3.47	2.1462	1.4625	8.52500	0.100000	0.00781	8.3336	
10	0.7150	5.72	0.2500	2	10.52969	0.4337	3.47	2.3587	1.6750	10.65000	0.100000	0.00781	10.4453	
12	0.7650	6.12	0.2500	2	12.51719	0.4337	3.47	2.5587	1.8750	12.65000	0.100000	0.00781	12.4328	

^A Maximum wrench-tightness is two turns past finger-tight. Over tightening may result in split fittings.

^B Reference dimension.

^C The length L_5 from the end of the pipe determines the plane beyond which the thread form is incomplete at the crest. The next two threads are complete at the root. At this plane the cone formed by the crests of the thread intersects the cylinder forming the external surface of the pipe, $L_5 = L_2 - 2p$.

iTeh Standards

4.9 *Inspection*—A gaging method of tolerances is prescribed in this specification to effect a functional inspection of the hand-tight L_1 engagement threads. However, conformance to this specification requires that all basic design dimensions be met (within applicable tolerances) including extension of the thread elements ($L_2 - L_1$) to provide for wrench-tight makeup. Therefore, additional methods of gaging may be employed to evaluate conformance to the basic design dimensions. When additional methods of gaging are employed, they shall be agreed upon between the supplier and the purchaser. Because it is known that injection molded threads that are removed from the mold before they are completely cooled will distort in form so that they will not gage properly, threads suspected of being so distorted should be inspected with an optical comparator to determine their true quality.

5. Specification for General Purpose Taper Pipe Threads, NPT

5.1 *Taper Pipe Threads*—Threads made in accordance with these specifications consist of an external taper and an internal taper thread, to form a normal type of joint having general application on pipe and fittings (see Fig. 3). The NPT taper pipe threads are intended to be made up wrench-tight (maximum two turns past finger-tight), and with a lubricant or sealant whenever a pressure-tight or leak-tight non-pressure joint is required (see 4.7 and 4.8). Sealing is affected by out-of-roundness which is possible between the wrench-tight mated parts in final assembly. This will vary depending on the method for producing the thread in conjunction with the elasticity or ductility, or both, of the mating parts and the resultant conformance at final assembly.

5.1.1 *Thread Designation and Notation*—American National Standard Taper Pipe Threads are designated in accordance with 3.2 as follows: 3/8-18 NPT.

5.1.1.1 Standard notation applicable to American National Standard Taper Pipe Threads is shown in Fig. 4.

5.1.2 Form of Thread:

5.1.2.1 The basic dimensions of American National Standard Pipe Threads, NPT, are given in Table 3 (wrench makeup has been changed from three turns to two turns for sizes 2 in. and smaller), which is for machined threads. (See 4.1.)

5.1.2.2 The basic dimensions of molded taper pipe threads for pressure fittings are given in Table 4. The overall length (L_4) is slightly less than that of American National Standard Taper Pipe Threads, NPT, because there are no vanish threads.

5.1.2.3 The basic dimensions of molded taper pipe threads for DWV fittings are given in Table 5. The overall length (L_4) is shorter than that of American National Standard Taper Pipe Threads, NPT, and molded pressure fitting threads.

5.1.2.4 The basic dimension of molded taper pipe threads for DWV plugs and cleanout fittings are given in Table 6. These threads are shorter than DWV threads.

5.1.3 *Taper of Thread*—The taper of the thread is 1 in 16 or 0.75 in./ft measured on the diameter and along the axis.

5.1.4 *Diameter of Thread*—The basic pitch diameter of the taper thread is determined by the following formulas based on the outside diameter of the pipe and the pitch of the thread:

$$E_o = D - (0.05D + 1.1)/n \tag{3}$$

$$= D - (0.05D + 1.1)p$$

$$E_1 = E_o + 0.0625L_1$$



TABLE 4 Basic Dimensions of Molded Taper Pipe Threads for Pressure Fittings^A

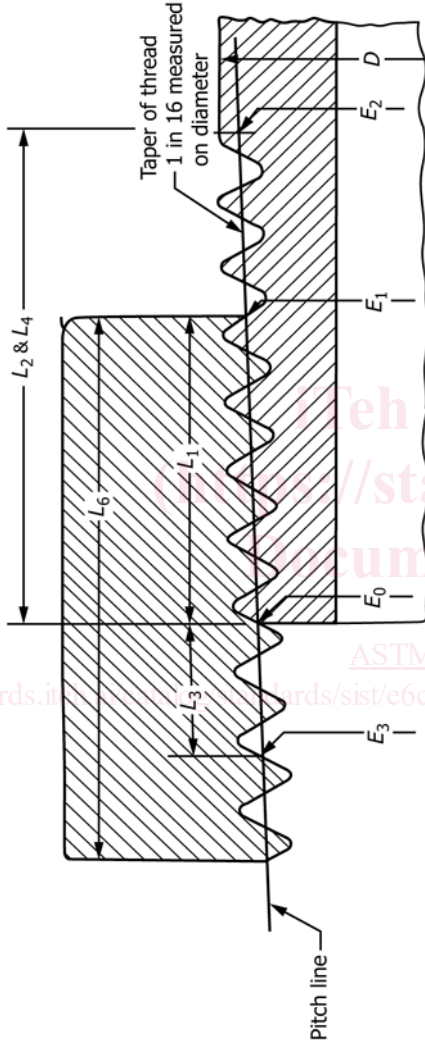

Nominal Pipe Size, in.	Outside Diameter of Pipe (D)	Threads/in. (n)	Pitch of Thread (P)	Pitch Diameter at Beginning of External Thread (E _o)	Hand-tight Gage Engagement			Overall Thread Length (L _o) and Effective Thread, External (L ₂)			Wrench Makeup Length for Internal Thread ^B			Overall Thread Length, Internal (L ₆)				
					Length (L ₁)		Length, min		Diameter (E ₂)		Length (L ₃)		Diameter (E ₃)		Inch	Threads	Inch	Threads
					Inch	Threads	Inch	Threads	Inch	Threads	Inch	Threads	Inch	Threads	Inch	Threads	Inch	Threads
1/8	0.405	27	0.03704	0.36351	0.1615	4.36	0.37360	8.37	0.38284	0.1485	3.01	0.0741	2	0.35889	0.3800	10.30		
1/4	0.540	18	0.05556	0.47739	0.2278	4.10	0.49163	7.92	0.50487	0.2122	3.82	0.1111	2	0.47045	0.5000	9.00		
3/8	0.675	18	0.05556	0.61201	0.240	4.32	0.62701	0.4400	0.63949	0.2000	3.60	0.1111	2	0.60507	0.5000	9.00		
1/2	0.840	14	0.07143	0.75843	0.320	4.48	0.77843	0.5300	0.79152	0.2100	2.94	0.1429	2	0.74951	0.6400	8.96		
3/4	1.050	14	0.07143	0.96768	0.339	4.75	0.98887	0.5500	1.00202	0.2110	2.95	0.1429	2	0.95876	0.6500	9.10		
1	1.315	11.5	0.08696	1.21363	0.400	4.60	1.23863	0.6800	1.25609	0.2800	3.22	0.1739	2	1.20277	0.8100	9.32		
1 1/4	1.660	11.5	0.08696	1.55713	0.420	4.83	1.58338	0.7100	1.60144	0.2900	3.33	0.1739	2	1.54627	0.8500	9.78		
1 1/2	1.900	11.5	0.08696	1.79609	0.420	4.83	1.82234	0.7200	1.84105	0.3000	3.45	0.1739	2	1.78523	0.8500	9.78		
2	2.375	11.5	0.08696	2.26902	0.436	5.01	2.29627	0.7600	2.31648	0.3240	3.73	0.1739	2	2.25816	0.9000	10.35		
2 1/2	2.875	8	0.12500	2.71953	0.682	5.46	2.76216	1.1400	2.79076	0.4580	3.66	0.2500	2	2.70391	1.2100	9.68		
3	3.500	8	0.12500	3.34062	0.766	6.13	3.38850	1.2000	3.41560	0.4340	3.47	0.2500	2	3.32500	1.3000	10.40		
4	4.500	8	0.12500	4.33438	0.844	6.75	4.38712	1.3000	4.41560	0.4560	3.65	0.2500	2	4.31875	1.3800	11.04		
6	6.625	8	0.12500	6.44609	0.958	7.66	6.50597	1.4400	6.53606	0.4820	3.86	0.2500	2	6.43047	1.6000	12.80		
8	8.625	8	0.12500	8.43359	1.063	8.50	8.50003	1.6300	8.53543	0.5670	4.54	0.2500	2	8.41797	1.7800	14.24		

^A The basic dimensions of taper pipe threads for pressure fittings are given in inches to four or five decimal places. While this implies a greater degree of precision than is ordinarily attained, these dimensions are the basis of gage dimensions and are so expressed for the purpose of eliminating errors in computations. Molded pressure fitting threads are shorter than American National Standard Taper Pipe Thread, NPT, because there are no vanish threads.

^B Maximum wrench tightness is two turns past finger tight. Overtightening may result in split fittings.

^C Also pitch diameter at gaging notch (hand-tight plane).

TABLE 5 Basic Dimensions of Molded Taper Pipe Threads for DWV Fittings^A

(See Table 6 for threaded DWV plugs and cleanout fillings.)

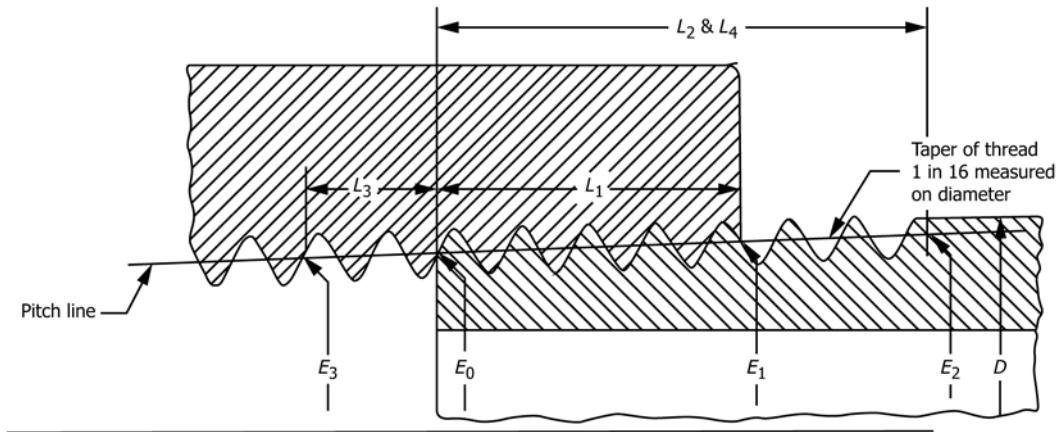

Nominal Pipe Size, in.	Outside Diameter of Pipe (D)	Threads/in. (n)	Pitch of Thread (P)	Pitch Diameter at Beginning of External Thread (E _o)	Hand-tight Gage Engagement		Overall Thread Length (L ₄) and Effective Thread, External (L ₂)				Wrench Makeup Length for Internal Thread ^B				
					Length (L ₁)		Length, min		Length, L ₁ Plane to L ₂ Plane External Thread (L ₂ - L ₁)		Length (L ₃)				
					Inch	Threads	Inch	Threads	Inch	Thread	Inch	Thread			
1	2	3	4	5	6	7	8	9	10	11	12	13	14	15	16
1¼	1.660	11.5	0.08696	1.55713	0.420	4.83	1.58338	0.687	7.91	1.60008	0.277	3.08	0.174	2	1.54627
1½	1.900	11.5	0.08696	1.79609	0.420	4.83	1.82234	0.687	7.91	1.83904	0.277	3.08	0.174	2	1.78523
2	2.375	11.5	0.08696	2.26902	0.436	5.01	2.29627	0.750	8.63	2.31588	0.314	3.61	0.174	2	2.25816
3	3.500	8	0.12500	3.34062	0.766	6.13	3.38850	1.187	9.50	3.41484	0.422	3.37	0.250	2	3.32500
4	4.500	8	0.12500	4.33438	0.844	6.75	4.38712	1.281	10.25	4.41444	0.437	3.50	0.250	2	4.31875
6	6.625	8	0.12500	6.44609	0.958	7.66	6.50597	1.500	12.00	6.53983	0.542	4.34	0.250	2	6.43047
8	8.625	8	0.12500	8.43359	1.063	8.50	8.50003	1.687	13.50	8.53905	0.625	5.00	0.250	2	8.41797

^A The basic dimensions of the DWV taper pipe thread are given in inches to four or five decimal places. While this implies a greater degree of precision than is ordinarily attained, these dimensions are the basis of gage dimensions and are so expressed for the purpose of eliminating errors in computations. DWV threads are shorter than American National Standard Taper Pipe Thread, NPT.

^B Maximum wrench-tightness is two turns past finger-tight. Over tightening may result in split fittings.

^C Also pitch diameter at gaging notch (hand-tight plane).

ASTM F1498-08(2020)

<https://standards.iteh.ai/catalog/standards/sist/e6c7453f-3af3-4174-98ee-10abe5009ed4/astm-f1498-082020>

where:

D = outside diameter of pipe, and
 E_o = pitch diameter of thread at end of pipe or small end of external thread.

NOTE 5—Formulas for the ½-27 and ¼-18 sizes,

$$E_o \text{ approximately } = D - (0.05D + 0.827)p \quad (4)$$

where:

E₁ = pitch diameter of thread at the gaging notch or large end of internal thread,
 L₁ = normal engagement by hand between external and internal threads (see Fig. 5), and
 n = threads per inch.

5.1.5 Length of Thread—The basic length of the effective external taper thread L₂ is determined by the following formula based on the outside diameter of the pipe and the pitch of the thread:

$$L_2 = (0.80D + 6.8)1/n \quad (5)$$

$$= (0.80D + 6.8)p$$

where:

D = outside diameter of pipe, and
 n = threads per inch.

This formula determines directly the length of effective thread which includes the usable threads slightly incomplete at the crest.

5.1.6 Engagement Between External and Internal Taper Threads—The normal length of engagement between external and internal taper threads when screwed together hand-tight is shown in Column 6 of Table 3, Table 4, Table 5, and Table 6. This length is controlled by the construction and use of the gages.

5.1.7 Basic Dimensions—The basic dimensions of taper pipe threads, derived from the above specifications, are given in Table 3, Table 4, Table 5, and Table 6. All dimensions are given in inches unless otherwise specified.

5.2 Tolerances: