



Designation: G84 – 89 (Reapproved 2020)

Standard Practice for Measurement of Time-of-Wetness on Surfaces Exposed to Wetting Conditions as in Atmospheric Corrosion Testing¹

This standard is issued under the fixed designation G84; the number immediately following the designation indicates the year of original adoption or, in the case of revision, the year of last revision. A number in parentheses indicates the year of last reapproval. A superscript epsilon (ϵ) indicates an editorial change since the last revision or reapproval.

1. Scope

1.1 This practice covers a technique for monitoring time-of-wetness (TOW) on surfaces exposed to cyclic atmospheric conditions which produce depositions of moisture.

1.2 The practice is also applicable for detecting and monitoring condensation within a wall or roof assembly and in test apparatus.

1.3 Exposure site calibration or characterization can be significantly enhanced if TOW is measured for comparison with other sites, particularly if this data is used in conjunction with other site-specific instrumentation techniques.

1.4 The values stated in SI units are to be regarded as standard. No other units of measurement are included in this standard.

1.5 *This standard does not purport to address all of the safety concerns, if any, associated with its use. It is the responsibility of the user of this standard to establish appropriate safety, health, and environmental practices and determine the applicability of regulatory limitations prior to use.*

1.6 *This international standard was developed in accordance with internationally recognized principles on standardization established in the Decision on Principles for the Development of International Standards, Guides and Recommendations issued by the World Trade Organization Technical Barriers to Trade (TBT) Committee.*

2. Summary of Practice

2.1 This practice describes a technique for detecting and recording surface moisture conditions. The moisture serves as an electrolyte to generate a potential in a moisture sensing element galvanic cell that consists of alternate electrodes of copper and gold, silver and platinum, or zinc and gold. The spacing of the electrodes may be 100 to 200 μm , the width dimension is not considered critical (Fig. 1). However, when

zinc is used as an electrode material, the effects of the hygroscopic nature of the corrosion products on the performance of the sensor should be kept in mind. Also, the use of copper as a sensor material should be avoided in sulfur dioxide-laden atmospheres to avoid premature deterioration of the sensor's copper substrate. The output (potential) from this cell is fed through a signal conditioning circuit to an indicating or recording device. The objective is to record the time that moisture is present on the sensing element during any given period. The fact that a potential is generated is critical to this technique. As pertains to this practice, the absolute value of the potential generated is essentially of academic interest.

2.2 This practice describes the moisture-sensing element, procedures for conditioning the elements to develop stable films on the electrodes and verifying the sensing-element function, and use of the element to record TOW.

3. Significance and Use

3.1 This practice provides a methodology for measuring the duration of wetness on a sensing element mounted on a surface in a location of interest. Experience has shown that the sensing element reacts to factors that cause wetness in the same manner as the surface on which it is mounted.

3.2 Surface moisture plays a critical role in the corrosion of metals and the deterioration of nonmetallics. The deposition of moisture on a surface can be caused by atmospheric or climatic phenomena such as direct precipitation of rain or snow, condensation, the deliquescence (or at least the hygroscopic nature) of corrosion products or salt deposits on the surface, and others. A measure of atmospheric or climatic factors responsible for moisture deposition does not necessarily give an accurate indication of the TOW. For example, the surface temperature of an object may be above or below both the ambient and the dew point temperatures. As a result condensation will occur without an ambient meteorological indication that a surface has been subjected to a condensation cycle.

3.3 Structural design factors and orientation can be responsible for temperature differences and the consequent effect on TOW as discussed in 4.2. As a result, some surfaces may be shielded from rain or snow fall; drainage may be facilitated or prevented from given areas, and so forth. Therefore various

¹ This practice is under the jurisdiction of ASTM Committee G01 on Corrosion of Metals and is the direct responsibility of Subcommittee G01.04 on Corrosion of Metals in Natural Atmospheric and Aqueous Environments.

Current edition approved Nov. 15, 2020. Published November 2020. Originally approved in 1981. Last previous edition approved in 2012 as G84–89(2012). DOI: 10.1520/G0084-89R20.

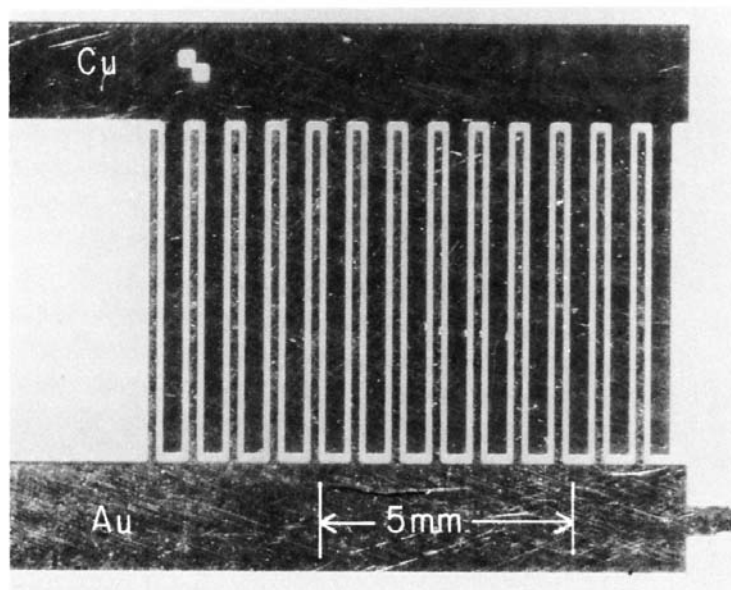

FIG. 1 Sensing Element

components of a structure can be expected to perform differently depending on mass, orientation, air flow patterns, and so forth. A knowledge of TOW at different points on large structures can be useful in the interpretation of corrosion or other testing results.

3.4 In order to improve comparison of data obtained from test locations separated on a macrogeographical basis, a uniform orientation of sensor elements boldly exposed in the direction of the prevailing wind, at an angle of 30° above the horizontal is recommended. Elevation of the sensor above ground level should be recorded.

3.5 Although this method does not develop relationships between TOW and levels of ambient relative humidity (RH), long term studies have been carried out to show that the TOW experienced annually by panels exposed under standard conditions is equivalent to the cumulative time the RH is above a given threshold value.² This time value varies with location and with other factors. Probability curves have been developed for top and bottom surfaces of a standard panel at one location which show the probable times that a surface will be wet as a percentage of the cumulative time the relative humidity is at specific levels.³ If needed, it should be possible to develop similar relationships to deal with other exposure conditions.

4. Sensor Preparation, Conditioning, and Calibration

4.1 The moisture sensing elements are manufactured by plating and selective etching of thin films of appropriate anode or cathode material on a thin, nonconducting substrate. These

elements may be procured from a commercial source.⁴ Thin sensing elements are preferred in order to preclude influencing the surface temperature to any extent. Although a sensor constructed using a 1.5 mm thick glass reinforced polyester base has been found to be satisfactory on plastic surfaces (low-thermal conductivity, and where the temperature of the sensing element was measured as being within ± 0.5 °C of the surface), this will not be the case with the same sensing element on a metal surface with a high-thermal conductivity. For metal surfaces, the sensing element should be appreciably thinner. Commercial epoxy sensor backing products of thickness of 1.5 mm, or less, are suitable for this purpose.

4.2 Checking the Moisture Sensing Elements:

4.2.1 Check the moisture sensing element for short circuiting due to low-resistance bridges between the electrodes or breakdown in the dielectric properties of the base. The open-circuit resistance between the two sets of electrodes should be in excess of 100 M Ω when the sensing element is dry (room condition at 50 % relative humidity or lower).

4.2.2 Check the action of the galvanic cell of the sensing element and the adequacy of the potting at the connection to external leads by immersing the sensing element, including the connection, for 1 h in an aqueous solution containing 10 mg/L of sodium chloride (NaCl) and 1 % ethanol. Under this condition, the potential measured should be in excess of 0.03 V for copper-gold cells and should remain at this value. For the sensor consisting of a zinc-gold cell, the potential measured

² Guttman, H., "Effects of Atmospheric Factors on Corrosion of Rolled Zinc," *Metal Corrosion in the Atmosphere*, ASTM STP 435. ASTM, 1968, pp. 223–239.

³ Sereda, P. J., Cross, S. G., and Slade, H. F., "Measurement of Time-of-Wetness by Moisture Sensors and Their Calibration," *Atmospheric Corrosion of Metals*, ASTM STP 767, ASTM, 1982, pp. 267–285.

⁴ The sole source of supply of the apparatus known to the committee at this time is the Sereda Miniature Moisture Sensor, Model SMMS-01, available from Epitek Electronics, Ltd., a Division of Epitek International Inc., 100 Schneider Road, Kanata, Ontario, Canada K2K1Y2. If you are aware of alternative suppliers, please provide this information to ASTM International Headquarters. Your comments will receive careful consideration at a meeting of the responsible technical committee,¹ which you may attend.

under this test should be in excess of 0.4 V. After immersion, rinse the sensor in distilled water and allow to dry.

4.3 Conditioning of the Sensing Element:

4.3.1 Activate sensors by spreading 1 drop of NaCl solution (10 mg/L of NaCl containing a wetting agent of 1 % ethanol or 0.1 % polyoxyethylene isooctylphenol) on the electrode grid.

4.3.2 Expose the activated sensor at 100 % relative humidity (in a desiccator over water) for a week. The resulting corrosion product film makes the activation more permanent. After being verified (see 4.4), store the sensor in a desiccator until ready for use.

4.3.2.1 **Warning**—The atmosphere in many laboratories can have contaminants that can affect the operation of the sensors (that is, HCl and SO₂ fumes, contact with fingers, organic nonwetting agents, and so forth). Since contamination effects have been observed, handle the sensors with care.

4.3.3 Fig. 2 and Fig. 3 illustrate a design of a simple conditioning chamber in which the sensing element can be exposed to 100 % relative humidity. To attain the desired conditions, mount the apparatus in a thermally insulated box located in a constant temperature room. It is desirable that the temperature of the humidity source in the chamber be controlled to ± 0.2 °C.

4.4 Verification of Sensing Element Functioning:

4.4.1 At 100 % RH, the copper-gold sensors should generate a potential in excess of 0.01 V and a potential in excess of 0.1 V for zinc-gold sensors. (The potential is essentially the voltage drop across a 10 M Ω resistance with the load and recorder having an input impedance in excess of 1000 M Ω .) The potential measured will decrease with time of measurement because of the depletion of available ions in the electrolyte. Leave the sensor cells in an open circuit while they are being verified. This step can take as little as 1 h if the temperatures are constant.

5. Field Installation and Maintenance of Sensor

5.1 Mount the sensing element in intimate contact with the surface to be monitored using suitable adhesive or a double-faced, 3/4 in. (20 mm) wide tape taking care to avoid contamination of the sensor with the fingers.⁵

5.2 Clean the sensing elements at least annually in the case of copper-gold sensors and every six months in the case of zinc-gold sensors. Cleaning is achieved by lightly brushing the grid along its length. Deionized or distilled water and a soft, clean toothbrush are recommended.

6. Signal Conditioning and Data Recording

6.1 The high-impedance and low-signal voltage output of the moisture sensor requires that the signal be conditioned to allow it to be interfaced with a data-recording device. Such a circuit (Fig. 4) has been described by Sereda et al,³ and is

⁵ Scotch brand polyester film No. 75, manufactured by Minnesota Mining and Manufacturing Co., St. Paul, MN, or equivalent is suitable. If you are aware of alternative suppliers, please provide this information to ASTM International Headquarters. Your comments will receive careful consideration at a meeting of the responsible technical committee,¹ which you may attend.

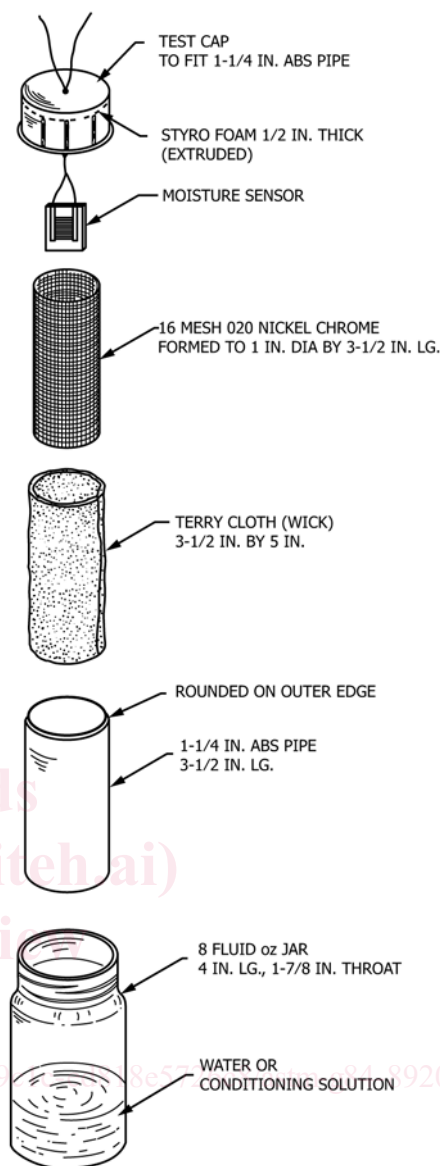

FIG. 2 Humidity Sensor Calibration Apparatus

available as a field usable off-the-shelf commercial modular interface unit.⁶ When using the circuit in Fig. 4, noted that the reference voltage (V_{ref}) value for the integrated circuit (IC1) is determined by the output voltage of the sensor, for example, 0.01 V for copper-gold and 0.10 V for zinc-gold sensors. The design of the circuit is such that there is a 4 W minimum recorder load requirement which would make long-term battery power supply operation of the interface inconvenient. The commercial interface unit offers a 5 V logic compatible output (CMD5, TTL, and so forth) or an amplified (50 \times) analog signal.

⁶ The sole source of supply of the apparatus known to the committee at this time is the Moisture Sensor Interface, Model WSI-01, available from Epitek Electronics, Ltd., a Division of Epitek International, Inc., 100 Schneider Road, Kanata, Ontario, Canada, K2K1Y2. If you are aware of alternative suppliers, please provide this information to ASTM International Headquarters. Your comments will receive careful consideration at a meeting of the responsible technical committee,¹ which you may attend.

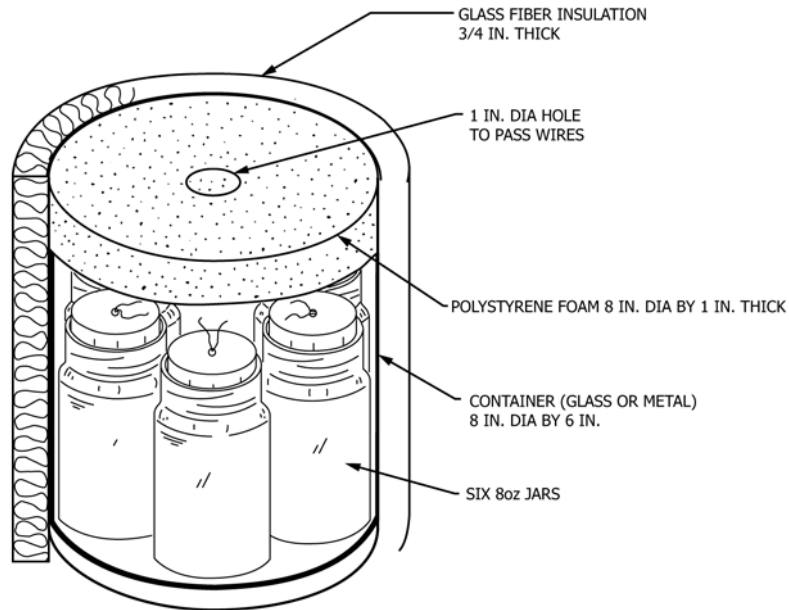
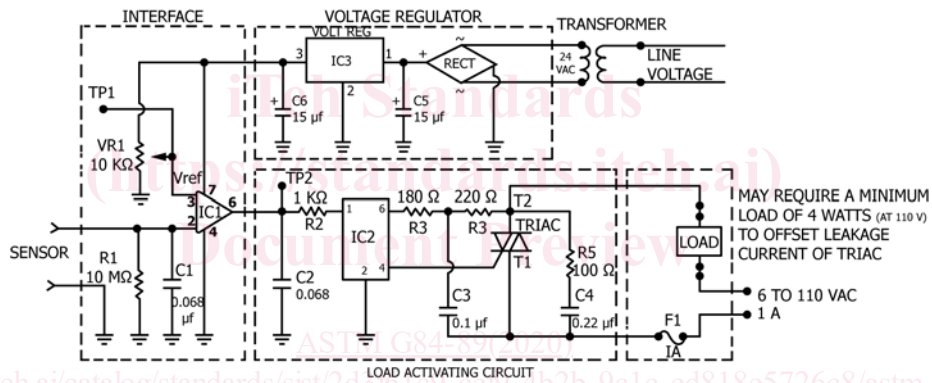

FIG. 3 Humidity Sensor Calibration Apparatus



VOLTAGE REGULATOR

—Receives voltage from power line transformer and provides a regulated D.C. voltage to the interface circuit.

INTERFACE CIRCUIT

—Reference voltage (0.010 or 0.10V) is derived from potentiometer VR1. Reference voltage can be adjusted at test point 1 (TP1).
 —Operational amplifier IC1 compares reference voltage (Pin 3) and sensor voltage (Pin 2), and activates the relay circuit when sensor voltage is greater than reference voltage (Pin 6).

LOAD ACTIVATING CIRCUIT

—Comparator IC1 output is fed to optoisolator IC2 which provides triggering pulses to triac T1.
 —Triac T1 permits current to flow through the load (running time meter or alarm).

PARTS LIST

IC1	CA 3140E OP-AMP
IC2	MOC 301 Triac Driver
IC3	LM-340T-12 Voltage Regulator
	RCA T2850B

Triac

FIG. 4 Line Powered Wetness Detector

A low-power battery supply version of the circuit in Fig. 4 has been developed⁷ and is shown in Fig. 5. This circuit gives the device true unattended field operation capability. The recording device can either be a relay-operated analog timing device or an integrated circuit-driven counter.⁸

⁷ Centre de Recherche Noranda, 240 Boulevard Hymus, Pointe-Claire, Quebec H9R 1G5.

⁸ Veeder-Root Model 7998 Mini-LX Totalizer or other comparable commercial equivalent, available from Digital Systems Division, Hartford, CT 06102 is suitable. If you are aware of alternative suppliers, please provide this information to ASTM International Headquarters. Your comments will receive careful consideration at a meeting of the responsible technical committee,¹ which you may attend.

7. Time-of-Wetness Report

7.1 When potential is recorded by means of a recorder or data-logging system, the potential readings can be processed as frequency distribution giving the percent of time when various levels of potential are exceeded. This provides the TOW for any selected level of potential.³

7.2 Record the TOW and report as a percent of total time for each month.