



Designation: D7299 – 20

Standard Practice for Verifying Performance of a Vertical Inclinometer Probe¹

This standard is issued under the fixed designation D7299; the number immediately following the designation indicates the year of original adoption or, in the case of revision, the year of last revision. A number in parentheses indicates the year of last reappraisal. A superscript epsilon (ϵ) indicates an editorial change since the last revision or reappraisal.

1. Scope*

1.1 This practice describes three function tests that together can be used to verify that a vertical traversing inclinometer probe is working properly.

1.2 This practice does not address calibration routines, electronic diagnostics, or repair of the probe, nor does it address inspection of the probe's mechanical parts.

1.3 This practice is not intended to replace manufacturers' recommendations for servicing and calibration of inclinometer equipment, nor is it intended to replace maintenance and calibration schedules established by users as part of their quality programs.

1.4 *Units*—The values stated in SI units are to be regarded as standard. No other units of measurement are included in this standard.

1.5 All observed and calculated values shall conform to the guidelines for significant digits and rounding established in Practice D6026.

1.6 *This practice offers a set of instructions for performing one or more specific operations. This document cannot replace education or experience and should be used in conjunction with professional judgment. Not all aspects of this practice may be applicable in all circumstances. This ASTM standard is not intended to represent or replace the standard of care by which the adequacy of a given professional service must be judged, nor should this document be applied without consideration of a project's many unique aspects. The word "standard" in the title of this document means only that the document has been approved through the ASTM consensus process.*

1.7 *This standard does not purport to address all of the safety concerns, if any, associated with its use. It is the responsibility of the user of this standard to establish appropriate safety, health, and environmental practices and determine the applicability of regulatory limitations prior to use.*

1.8 *This international standard was developed in accordance with internationally recognized principles on standard-*

¹ This practice is under the jurisdiction of ASTM Committee D18 on Soil and Rock and is the direct responsibility of Subcommittee D18.23 on Field Instrumentation.

Current edition approved Nov. 1, 2020. Published November 2020. Originally approved in 2006. Last previous edition approved in 2012 as D7299 – 12. DOI: 10.1520/D7299-20.

ization established in the Decision on Principles for the Development of International Standards, Guides and Recommendations issued by the World Trade Organization Technical Barriers to Trade (TBT) Committee.

2. Referenced Documents

2.1 *ASTM Standards:*²

D653 Terminology Relating to Soil, Rock, and Contained Fluids

D3740 Practice for Minimum Requirements for Agencies Engaged in Testing and/or Inspection of Soil and Rock as Used in Engineering Design and Construction

D6026 Practice for Using Significant Digits in Geotechnical Data

3. Terminology

3.1 For definitions of common technical terms used in this standard, refer to Terminology D653.

3.2 *Definitions of Terms Specific to This Standard:*

3.2.1 *inclinometer casing, n*—a special-purpose pipe, typically installed in boreholes, with internal guide grooves that control the orientation of the inclinometer probe and that provide a flat surface for repeatable tilt measurements.

3.2.2 *inclinometer survey, n*—a set of readings obtained with the inclinometer probe and readout.

3.2.3 *vertical inclinometer probe, n*—an instrument comprised of a downhole probe which uses internal sensors to detect its own orientation relative to the force of gravity, with a wheel assembly for lowering into the inclinometer casing along the alignment grooves, connected by a cable to a readout or datalogger at the surface.

3.2.4 *zero offset, n*—non-zero values reported by the A-axis and B-axis sensors when the probe is held precisely vertical.

4. Significance and Use

4.1 Inclinometer monitoring programs often run several years or more. During this time, hundreds of surveys can be collected. Each new survey is processed by comparing it to a baseline survey.

² For referenced ASTM standards, visit the ASTM website, www.astm.org, or contact ASTM Customer Service at service@astm.org. For *Annual Book of ASTM Standards* volume information, refer to the standard's Document Summary page on the ASTM website.

*A Summary of Changes section appears at the end of this standard

4.2 Over a period of years, normal wear and tear can gradually degrade the probe's ability to produce new surveys that are directly comparable to the baseline survey. This may go unnoticed for some time, because the quality of readings may degrade in very small increments.

4.3 When function tests are incorporated into an inclinometer monitoring program, the degradation of reading quality can be avoided. Probes that pass the tests can be used with confidence. Probes that fail the tests shall be returned to the probe manufacturer for servicing. It shall be noted that manufacturers calibrate inclinometer probes using high-precision, electronically-controlled equipment in temperature-controlled environments. Ordinary users do not have access to such equipment, so the pass/fail criteria suggested for these tests accommodate typical results produced by less precise equipment in a less controlled environment.

NOTE 1—The quality of the result produced by this standard is dependent on the competence of the personnel performing it and the suitability of the equipment and facilities used. Agencies that meet the criteria of Practice D3740 are generally considered capable of competent and objective testing/sampling/inspection/etc. Users of this standard are cautioned that compliance with Practice D3740 does not in itself assure reliable results. Reliable results depend on many factors; Practice D3740 provides a means of evaluating some of those factors.

5. Apparatus

5.1 Two pieces of equipment are suggested: a rotary table test stand and a test casing. All the tests could be performed using only the rotary table test stand, but operation of the rotary table requires a trained operator working slowly and deliberately. The test casing, on the other hand, provides a simple test that can be used frequently by any inclinometer user after a few minutes of training.

5.2 Rotary Table Test Stand:

5.2.1 The rotary table test stand (Fig. 1) consists of a rotary table mounted on a pedestal. The rotary table is a device that is commonly used in precision machining operations. In machine shops, rotary tables are usually mounted horizontally. In this

case, the table is mounted vertically, so that it can move the probe through its specified tilt range. A suitable rotary table will offer a placement accuracy of 30 seconds of arc or better throughout its range. It shall provide an adjustable dial on the hand wheel that reads directly to each minute of arc, and a Vernier plate that permits direct reading to within 5 s. The Vernier scale is used to make the various test measurements.

5.2.2 Make the pedestal from a steel I-beam or a steel pipe approximately 150 mm diameter and cut to a convenient height. Steel is a commonly available material but other metals may also be suitable. Make plates for the top and bottom of the pedestal using 0.5-in. (12.5 mm) thick steel. Mill the top plate flat for proper mounting of the rotary table. Drill bolt holes in the base plate, as shown in Fig. 1. Weld the steel plates to the two ends of the beam or pipe. Choose a location for the stand and set bolts into stable flooring, such as a concrete floor slab. Ideally, the location will be free from vibration. Place the test stand onto the bolts. Place steel shims under the bottom plate so that the top plate is completely horizontal, as indicated by a machinist's bubble level. Tighten nuts on the floor bolts.

5.2.3 Mount the rotary table to the top plate as shown in Fig. 1. Place steel shims as necessary to make the plane of the table vertical. Make a probe holder from aluminum tubing approximately 50 mm square-section. The square section tubing holds the wheels tightly, in a fixed, repeatable position. Inclinometer casing is not a suitable substitute for the tubing, since casing grooves are purposely made wider to facilitate passage of the probe through deformed casing. Mount the probe holder to the rotary table using two V-blocks, fitting the holder so that it provides two possible positions for the probe, one parallel to the rotary table, and the other perpendicular to the table.

5.2.4 Devise a means of applying a constant torque to the table to compensate for backlash in the gears and improve the precision with which the table can be rotated. Fig. 1 shows a weight suspended from a wire rope that is attached to the table. Wrap the wire rope over the top of the table so that the weight

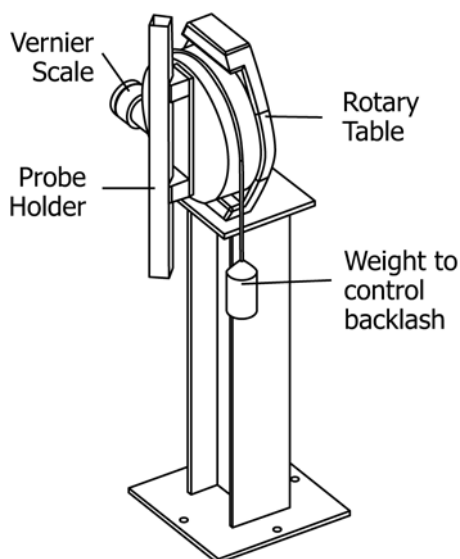

FIG. 1 Rotary Table Test Stand

assists rotation toward positive angles (typically clockwise) as read from the scales on the rotary table.

5.3 Test Casing:

5.3.1 The test casing (Fig. 2) consists of a short length of inclinometer casing, a steel pipe of sufficient diameter to hold inclinometer casing, and a square steel base plate that can be secured to bolts set into a concrete floor slab.

5.3.2 Drill bolt holes in the base plate. Weld the steel pipe to the base plate. Attach a bottom cap to the inclinometer casing and seal it so that grout will not enter. Place inclinometer casing inside the steel pipe. Align the casing so that its four guide grooves point to the four sides of the base. Use cement grout to fix the casing within the pipe.

5.3.3 Place the completed test casing onto the floor bolts, but do not tighten the nuts yet.

5.3.4 Choose one of the four grooves in the casing to be the A+ groove. Mark it as the A+ groove. The B+ groove is located 90° clockwise. Mark it as the B+ groove.

5.3.5 Connect the probe to the readout, and turn on the power. Orient the probe so that the upper wheels of both wheel sets are aligned with the A+ groove, and insert the probe into the casing. Allow the probe 10 minutes for warm up.

5.3.6 Calculate what value on the display is the equivalent of 1°. Use the manufacturer’s instrument constant to convert from display units to degrees. Tilt the test casing until the display shows the equivalent of 1° tilt in both the A+ and B+ directions. Place steel shims under the base plate to maintain this tilt and then tighten the bolts. Installing the test casing with this small tilt ensures that test readings will maintain their expected signs regardless of any zero offset in the sensors.

6. Test of Repeatability

6.1 This test verifies that the probe can provide repeatable readings at a selected test angle after it has been moved through its entire tilt range, which is nominally ±30° for most probes.

6.2 The test employs the rotary table test stand and requires an understanding of the rotary table and how its scales are read. To make positioning of the table as precise as possible, always approach the test angle from the direction opposite that of the applied torque of the suspended weight. In other words, if the applied torque acts clockwise, approach the test angles via a counter-clockwise rotation. If a clockwise rotation is required to reach the test angle, then the table shall be rotated through the test angle, passing it by about 20 arc-min, and then returned to the test angle by a counter-clockwise rotation.

6.3 Connect control cable to the probe and to the readout. Switch on the readout to provide power to the probe. Wait 10 minutes, with the probe powered, before continuing the procedure.

6.4 Begin the A-axis test. Hold the probe so that its wheels are parallel with the rotary table and the upper wheel of each wheel set is pointed toward the direction of positive angles. Insert the probe into the probe holder.

6.5 Rotate the table to a starting point of -90°. Now rotate the table through the zero to about +1° 20'. Then slowly return the table to exactly +1°. Do not overshoot the +1° mark. If this happens, start again from the -90° position.

6.6 With the table at exactly +1°, record the reading. This will be the target reading for the subsequent steps.

6.7 Rotate the table to a new starting point of +90°. Then rotate the table back toward +1°. Watch the display and slow the rotation speed as the target reading is approached. Continue until the target reading is displayed. If the target reading is missed, start again from +90°.

6.8 With the target reading displayed, check the Vernier scale. It shall show no more than ±30 arc-seconds away from +1°. Repeat steps 3 through 5 to obtain a second set of readings. Again, the repeatability shall be within ±30 arc-seconds from +1° on the Vernier scale.

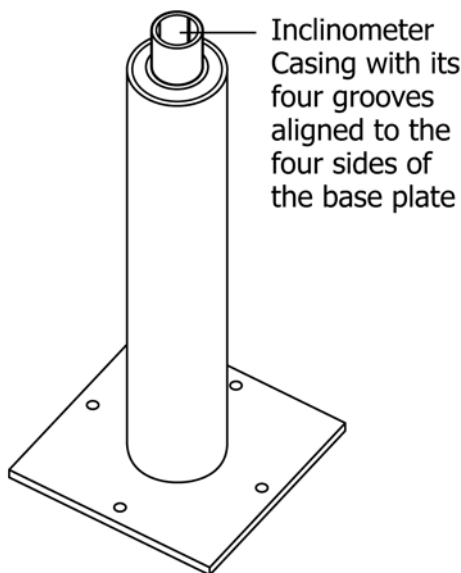

FIG. 2 Test Casing