



Designation: **E810–03 (Reapproved 2013) E810 – 20**

Standard Test Method for Coefficient of Retroreflection of Retroreflective Sheeting Utilizing the Coplanar Geometry¹

This standard is issued under the fixed designation E810; the number immediately following the designation indicates the year of original adoption or, in the case of revision, the year of last revision. A number in parentheses indicates the year of last reapproval. A superscript epsilon (ϵ) indicates an editorial change since the last revision or reapproval.

1. Scope

- 1.1 This test method describes an instrument measurement of the retroreflective performance of retroreflective sheeting.
- 1.2 The user of this test method must specify the entrance and observation angles to be used, and may specify the rotation angles.
- 1.3 This test method is intended as a laboratory test and requires a facility that can be darkened sufficiently so that stray light does not affect the test results. The testing apparatus must be able to achieve the coplanar geometry.
- 1.4 Portable and bench retroreflection measuring equipment may be used to determine R_A values provided the geometry and appropriate substitution standard reference panels, measured in accordance with this test method, are utilized. In this case the methods of Procedure B in Practice E809 apply. Additional information on the use of portable retroreflectometers may be found in Test Method E1709.
- 1.5 *This standard does not purport to address all of the safety concerns, if any, associated with its use. It is the responsibility of the user of this standard to establish appropriate safety, health, and environmental practices and determine the applicability of regulatory limitations prior to use.*
- 1.6 *This international standard was developed in accordance with internationally recognized principles on standardization established in the Decision on Principles for the Development of International Standards, Guides and Recommendations issued by the World Trade Organization Technical Barriers to Trade (TBT) Committee.*

2. Referenced Documents

2.1 ASTM Standards:²

- [E177 Practice for Use of the Terms Precision and Bias in ASTM Test Methods](#)
- [E284 Terminology of Appearance](#)
- [E308 Practice for Computing the Colors of Objects by Using the CIE System](#)
- [E691 Practice for Conducting an Interlaboratory Study to Determine the Precision of a Test Method](#)
- [E808 Practice for Describing Retroreflection](#)
- [E809 Practice for Measuring Photometric Characteristics of Retroreflectors](#)
- [E1709 Test Method for Measurement of Retroreflective Signs Using a Portable Retroreflectometer at a 0.2 Degree Observation Angle](#)

¹ This test method is under the jurisdiction of ASTM Committee E12 on Color and Appearance and is the direct responsibility of Subcommittee E12.10 on Retroreflection. Current edition approved Jan. 1, 2013; Oct. 1, 2020. Published January 2013; November 2020. Originally approved in 1981. Last previous edition approved in 2008; 2013 as E810 – 03 (2008); (2013). DOI: 10.1520/E0810-03R13; 10.1520/E0810-20.

² For referenced ASTM standards, visit the ASTM website, www.astm.org, or contact ASTM Customer Service at service@astm.org. For Annual Book of ASTM Standards volume information, refer to the standard's Document Summary page on the ASTM website.

2.2 Other Document:

CIE Publication No 54 Retroreflection—Definition and Measurement³

3. Terminology

3.1 The terms and definitions in Terminology E284 and Practice E808 apply to this test method.

3.2 Definitions:

3.2.1 *coefficient of retroreflection, R_A* —of a plane retroreflecting surface, the ratio of the coefficient of luminous intensity (R_I) to the area (A), expressed in candelas per lux per square metre ($\text{cd}\cdot\text{lx}^{-1}\cdot\text{m}^{-2}$). $R_A = R_I/A$.

3.2.1.1 Discussion—

The equivalent inch–pound units for coefficient of retroreflection are candelas per foot-candle per square foot ($\text{cd}\cdot\text{fc}^{-1}\cdot\text{ft}^{-2}$). The SI and inch pound units are numerically equal, because the units of R_A reduce to $1/\text{sr}$. An equivalent term used for coefficient of retroreflection is specific intensity per unit area, with symbol SIA or the CIE symbol R' . The term coefficient of retroreflection and the symbol R_A along with the SI units of candelas per lux per square meter ($\text{cd}\cdot\text{lx}^{-1}\cdot\text{m}^{-2}$) are recommended by ASTM.

3.2.1.2 Discussion—

R_A is a useful engineering quantity for determining the photometric performance of such retroreflective surfaces as highway delineators or warning devices. R_A may also be used to determine the minimum area of retroreflective sheeting necessary for a desired level of photometric performance. R_A has been used extensively in the specification of retroreflective sheeting.

3.2.2 *coplanar geometry, n* —retroreflection geometry in which the retroreflector axis, illumination axis, and observation axis lie in one plane.

3.2.2.1 Discussion—

In the coplanar geometry: the second entrance angle component, β_2 , is equal to 0° ; presentation angle, γ , is equal to either 0° or 180° ; orientation angle, ω_s , is equal to either the rotation angle, ε , or to $\varepsilon + 180^\circ$ or $\varepsilon - 180^\circ$.

3.2.3 *datum axis, n* —a designated half-line from the retroreflector center perpendicular to the retroreflector axis.

3.2.4 *datum mark, n* —an indication on the retroreflector, off the retroreflector axis, that establishes the direction of the datum axis.

3.2.5 *entrance angle, β, n* —the angle between the illumination axis and the retroreflector axis.

3.2.5.1 Discussion—

The entrance angle is usually no larger than 90° , but for completeness its full range is defined as $0^\circ \leq \beta \leq 180^\circ$. In the CIE (goniometer system) β is resolved into two components β_1 and β_2 . Since by definition β is always positive, the common practice of referring to the small entrance angles that direct specular reflections away from the photoreceptor as a negative value is deprecated by ASTM. The recommendation is to designate such negative values as belonging to β_1 .

3.2.6 *goniometer, n* —an instrument for measuring or setting angles.

3.2.7 *illumination axis, n* —the half-line from the retroreflector center through the source point.

3.2.8 *observation angle, α, n* —the angle between the illumination axis and the observation axis.

3.2.8.1 Discussion—

The observation angle is never negative and is almost always less than 10° and usually no more than 2° . The full range is defined as $0^\circ \leq \alpha < 180^\circ$.

3.2.9 *observation axis, n* —the half-line from the retroreflector center through the observation point.

3.2.10 *receiver, n* —the portion of a photometric instrument that receives the viewing beam from the specimen, including a collector such as an integrating sphere, if used, often the monochromator or spectral filters, the detector, and associated optics and electronics.

³ Available from the CIE Webshop at <http://www.cie.co.at>. U.S. National Committee of the CIE (International Commission on Illumination) (<http://www.cie-usnc.org>) or the CIE (<http://www.cie.co.at>) Webshop.

3.2.11 *retroreflection, n*—reflection in which the reflected rays are preferentially returned in directions close to the opposite of the direction of the incident rays, this property being maintained over wide variations of the direction of the incident rays. [CIE]^B

3.2.12 *retroreflective material, n*—a material that has a thin continuous layer of small retroreflective elements on or very near its exposed surface (for example, retroreflective sheeting, retroreflective fabrics, transfer films, beaded paint, highway surface signs, or pavement striping).

3.2.13 *retroreflective sheeting, n*—a retroreflective material preassembled as a thin film ready for use.

~~3.2.14 *retroreflector, n*—a reflecting surface or device from which, when directionally irradiated, the reflected rays are preferentially returned in directions close to the opposite of the direction of the incident rays, this property being maintained over wide variations of the direction of the incident rays. [CIE, 1982]^B~~

3.2.14 *retroreflector, n*—a reflecting surface or device from which, when directionally irradiated, the reflected rays are preferentially returned in directions close to the opposite of the direction of the incident rays, this property being maintained over wide variations of the direction of the incident rays. [CIE, 1982]^B

3.2.15 *retroreflector axis, n*—a designated half-line from the retroreflector center.

3.2.15.1 *Discussion*—

The direction of the retroreflector axis is usually chosen centrally among the intended directions of illumination; for example, the direction of the road on which or with respect to which the retroreflector is intended to be positioned. The retroreflector axis usually coincides with the axis of symmetry of the retroreflector. For retroreflective sheeting the normal to the surface is chosen as the retroreflector axis.

3.2.16 *retroreflector center, n*—the point on or near a retroreflector that is designated to be the location of the device.

3.2.17 *rotation angle, ϵ , n*—the angle in a plane perpendicular to the retroreflector axis from the observation half-plane to the datum axis, measured counterclockwise from a viewpoint on the retroreflector axis.

3.2.17.1 *Discussion*—

Range: $-180^\circ < \epsilon \leq 180^\circ$. The definition is applicable when entrance angle and viewing angle are less than 90° . More generally, rotation angle is the angle from the positive part of second axis to the datum axis, measured counterclockwise from a viewpoint on the retroreflector axis.

3.2.17.2 *Discussion*—

Rotation of the sample about the retroreflector axis while the source and receiver remain fixed in space changes the rotation angle (ϵ) and the orientation angle (ω_s) equally.

3.2.18 *rotationally uniform, adj*—having substantially constant R_A , when rotated about the retroreflector axis, while the source, receiver, retroreflector center and retroreflector axis all remain in a fixed spatial relation.

3.2.18.1 *Discussion*—

The degree of rotational uniformity can be specified numerically.

3.2.19 *source, n*—an object that produces light or other radiant flux.

4. Summary of Test Method

4.1 This test method involves the use of a light projector source, a receiver, a device to position the receiver with respect to the source and a test specimen holder in a suitable darkened area. The specimen holder is separated from the light source by 15 m.

4.2 The general procedure involved is to determine the ratio of the light retroreflected from the test surface to that incident on the test surface.

4.3 The photometric quantity, coefficient of retroreflection, is calculated from these measurements.

5. Significance and Use

5.1 Measurements made by this test method are related to visual observations of retroreflective sheeting as seen by the human eye when illuminated by tungsten-filament light sources such as a motor vehicle headlamp.

5.2 The values determined relate to the visual effects for a given geometric configuration as specified by the user of the test method. This test method has been found useful for tests at observation angles between 0.1° and 2.0° (observation angles between 0.1° and 0.2° may be achieved by careful design of source and receiver aperture configuration), and at entrance angles up to 60° . It has been used to determine coefficient of retroreflection values as low as $0.1 \text{ cd}\cdot\text{lx}^{-1} \cdot \text{m}^{-2}$, but for values less than $1 \text{ cd}\cdot\text{lx}^{-1} \cdot \text{m}^{-2}$ special attention must be given to the responsivity of the receiver and to the elimination of very small amounts of stray light.

6. Apparatus

6.1 *Light Source*—The light source shall be of the projector type and shall meet the following requirements (an illuminance at the 15 m specimen distance of about 10 lx is commonly available within these restrictions):

6.1.1 The spectral energy distribution of the source shall be proportional to CIE standard Source A (a correlated color temperature of 2856 K, see Practice E308). The projection lamp together with the projection optics shall be operated such that it illuminates the test specimen with this spectral power distribution.

6.1.2 An unpolarizing light source shall be used.

6.1.3 The source aperture shall be a standard circular aperture as defined in Practice E809. For measurements at observation angles (α) of $0.2^\circ \leq \alpha \leq 2.0^\circ$, the exit aperture of the source shall be uniformly radiant, circular and 26 mm (± 2 mm) in diameter. This corresponds to 0.1° angular aperture at 15 m test distance. For measurements at observation angles (α) of $0.1^\circ \leq \alpha < 0.2^\circ$, the exit aperture of the source shall be uniformly radiant, circular and 13 mm (± 1 mm) in diameter. This corresponds to 0.05° angular aperture at 15 m test distance.

6.1.4 The illumination at the sample produced by the projector shall be such that the test specimen and only a minimum of the background is illuminated. This is commonly accomplished by placing a restrictive aperture in the projector slide port.

6.1.5 The source shall be regulated such that the illuminance at the test surface does not change by more than $\pm 1\%$ for the duration of the test.

6.1.6 The illuminance produced on the sample surface shall be uniform within $\pm 5\%$ of the average illuminance normal to the source at the distance of 15 m.

6.2 *Receiver*—The receiver shall meet the requirements that follow. (In this test, for 10 lx incident upon a $1 \text{ cd}\cdot\text{lx}^{-1} \cdot \text{m}^{-2}$ retroreflective sheeting test specimen with area of 0.04 m^2 , the incident normal illuminance at the receiver will be about 1.8×10^{-3} lx).

6.2.1 The responsivity and range of the receiver shall be sufficient so that readings of both the incident normal illuminance (at the specimen) and the retroreflected light at the observation position can be measured with a resolution of at least 1 part in 50 on the readout scale.

6.2.2 The spectral responsivity of the receiver shall match that of the 1931 CIE Standard Photopic Observer (see Annex A1 of Practice E809).

6.2.3 The receiver shall be insensitive to the polarization of light.

6.2.4 The linearity of the photometric scale over the range of readings to be taken shall be within $\pm 1\%$. Correction factors may be used to ensure a linear response. Linearity verification tests must be made utilizing the entire receiver readout device including the detector, load, range selection system and readout display device.

6.2.5 The stability of the receiver shall be such that readings from a constant source do not vary any more than 1% for the duration of the test.

6.2.6 The field of view shall be limited by use of light baffles or a field aperture on the instrument so that the entire test sample is fully within the field of view, rejecting stray light as much as practical. A background light level m_b less than 5 % of the smallest m_1 reading is acceptable.

6.2.7 The receiver aperture shall be a standard circular aperture as defined in Practice E809. For measurements at observation angles (α) of $0.2^\circ \leq \alpha \leq 2.0^\circ$, the receiver shall be provided with an entrance aperture 26 mm (± 2 mm) in diameter. This corresponds to 0.1° angular aperture at 15 m test distance. For measurements at observation angles (α) of $0.1^\circ \leq \alpha < 0.2^\circ$, the receiver shall be provided with an entrance aperture 13 mm (± 1 mm) in diameter. This corresponds to a 0.05° angular aperture at 15 m test distance. The size of the entrance aperture stop must be small so that the receiver may be positioned physically close to the source exit aperture without shadowing any of the illuminating light beam.

6.3 *Test Specimen Goniometer (Test Specimen Holder)*—The specimen holder must hold a 200 mm square specimen and meet the following requirements (see Fig. 1):

6.3.1 A means must be provided to rotate the specimen on an axis contained in the plane of the specimen surface if several entrance angles are to be used.

6.3.1.1 The entrance angle component β_1 is used to set the goniometer when no specific component is specified (see Practice E808).

6.3.2 The specimen surface must be positionable so that the entrance angle is accurate to within 0.5 % of its complement (that is, for a 30° entrance angle this angle must be accurately set to $\pm 0.005 \times 60^\circ = \pm 0.3^\circ$). This is obtainable by providing an accurate optical means to align the test surface to the “0 degree” entrance angle and then adjusting the angular setting (within the required tolerance).

6.3.3 The specimen holder must be provided with a means of eliminating reflections from the edges of the specimen and the holder itself must be nonreflective (usually painted with a flat black paint).

6.3.4 The specimen holder should be constructed such that the receiver can easily be substituted for the specimen (required when incident light measurements are taken).

6.4 *Observer Goniometer (Device for Receiver/Light Source Separation)*—A device (sometimes called an observation angle positioner) must be provided to adequately support and separate the receiver from the source at the observation position. It must allow the observation angle to be varied (see Fig. 2). The usual range is at least 0.2° to 2.0° .

6.4.1 The accuracy of separation of the source exit aperture from the receiver entrance aperture is dependent on the test sample.

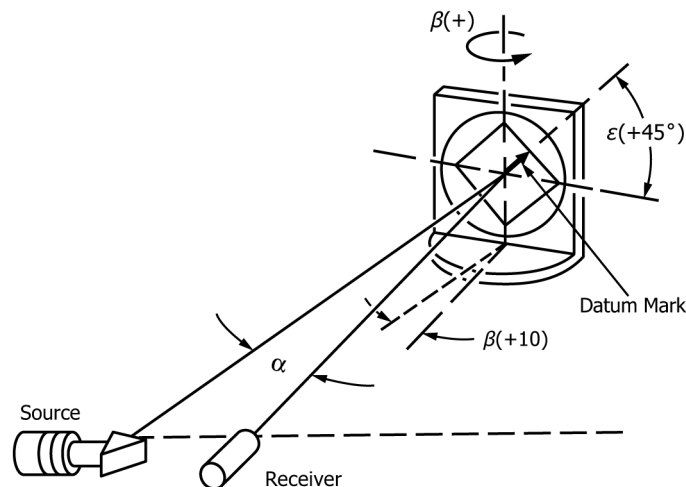

NOTE 1—This view shows the source-receiver in a horizontal plane and the entrance angle β ($= \beta_1$) as a rotation about a vertical axis. The rotation angle ϵ is shown at $+45^\circ$ for illustration purposes— default position is $\epsilon = 0^\circ$.

FIG. 1 Pictorial View of a Goniometer—Specimen Holder Assembly

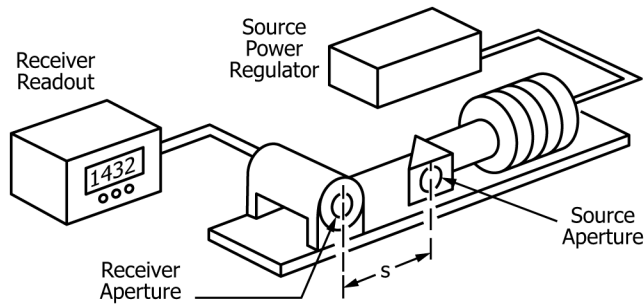

NOTE 1—The distance s is adjusted to correspond to the desired observation angle.

FIG. 2 Pictorial View of Observation Angle Positioning Device

For most materials, a positioning accuracy of ± 0.1 mm (or ± 0.5 % of the receiver angular subtense at 15 m distance) is adequate. A common method of fixing this distance is to provide a bar with holes machined in it at separations corresponding to the desired observation angles.

6.4.2 In this test method the minimum practical observation angle is approximately 0.2° using a receiver with an entrance aperture 26 mm (± 2 mm) in diameter. If an observation angle (α) of $0.1^\circ \leq \alpha < 0.2^\circ$ is to be used, a smaller aperture is needed as explained in 6.2.7.

6.5 Photometric Range—Sufficient working space is required so that the projector and sample can be separated by a 15 m distance.

6.5.1 The stray light in this facility must be such that it does not appreciably influence the test results. Flat black paint, black curtains, black tape and other means shall be used to eliminate unwanted light.

6.5.2 A measuring system must be provided in the photometric range to measure the 15 m test distance (from the retroreflector center to the receiver entrance aperture) accurately to ± 0.01 m.

7. Sampling

7.1 The sampling procedure used for this test method shall be such that the test material is representative of the roll or batch.

7.2 When a roll of retroreflective sheeting is tested, at least three 0.2 by 0.2 m specimens shall be taken from the roll which are representative of crossweb and downweb variations if any. The average value of these three specimens will be reported. One method of meeting this requirement is to take three specimens—left, center, and right—diagonally across the roll.

7.2.1 If there is no datum mark already on the material and if the leading edge of the roll is not already indicated on the cut sample, then a datum mark should be made on the back of the sample at the time of cutting to indicate the leading edge of the roll. If not otherwise agreed, this datum mark shall indicate 0° rotation angle for the test.

7.2.2 If a datum mark is already indicated on the material, this mark shall be used to orient the material for test as in 10.7.

7.3 When sampling a number of cut sheets of material, a random selection procedure will be used to ensure the sample is representative of the lot. At least three 0.2 by 0.2 m specimens will be selected and the average value reported.

7.4 When the material to be tested is smaller than 0.2 by 0.2 m in any dimension, the 0.2 by 0.2 m test specimen shall be obtained by piecing several small uniformly retroreflective parts together, with identical orientation, to form the required 0.2 by 0.2 m size test specimen.

8. Test Specimen and Sample

8.1 The test specimen in this procedure shall be 200 ± 10 mm by 200 ± 10 mm in size.

8.1.1 Discussion—The 200 mm square specimen with an area of 0.04 m² is suitable for most testing and convenient for storing

and handling. Historically a 300 mm square specimen (1 ft²) has been used but this large a specimen can be clumsy to handle and does not significantly improve test accuracy. Specimens 100 mm square have been successfully used with modern receiver systems.

8.2 The specimen, when tested, shall be flat. This can be accomplished by applying the sample to a flat test panel or by providing a means of keeping the specimen adhered in a flat manner to the sample holder by tape, spray adhesive, mechanical means, or vacuum.

8.3 When it is desired to compare readings or individual panels between laboratories, a retroreflector datum mark should be provided on the sample to permit the same sample orientation between laboratories. This may be done by marking an arrow on the back of the specimen pointing toward the center of one of the 200 mm sides. The direction of this arrow commonly corresponds to a “downweb” direction of manufacture.

9. Calibration and Standardization

9.1 Prior to performing any tests by this test method, the calibration of the apparatus must be verified.

9.2 The light source must be calibrated to match the spectral distribution of CIE Standard Source A. When the proper voltage or current has been established for this requirement, the values or setting shall be recorded and used during the measurement procedure (see Annex A3 of Practice E809).

9.3 The linearity of the receiver must be established. Either a set of data indicating that the receiver and readout device combination is linear when used over the range of the readings or a set of correction factors must be established (see Practice E809, Annex A2) that correct the readings for nonlinearity.

9.4 The spectral responsivity of the receiver must be verified to be a sufficiently close match to the 1931 CIE photopic observer, for the color of the products to be measured (see Practice E809, Annex A1).

10. Procedure

10.1 Set up the sample holder so that the center of the test specimen will be separated by 15.0 ± 0.2 m from the exit aperture of the light source. Measure the actual distance to ±0.01 m and record this reading as “d.” Align the sample holder by optical means (auto collimation) to the zero position so that the test surface is perpendicular to the source (that is, 0° entrance angle). In addition, align the sample holder so that the normal to the test surface is in the plane determined by the source exit aperture, receiver entrance aperture, and the sample center, as the entrance angle is changed (this corresponds to setting the second component of the entrance angle β₂ = 0° (see Practice E808 and Fig. 3).

10.2 By substituting the light source for the sample (preferred method), measure the illumination at four quadrants representative of equal areas, in the sample position (that is, for a 200 mm square specimen, 50 mm to left and right and 50 mm up and down from sample center) and with the receiver entrance aperture in a plane normal to the source with this plane passing through the sample center position. When making this measurement, the source exit aperture is to be centered in the field of view of the receiver. Record the mean of the four readings as the initial incident illuminance, m₂. Individual readings must not vary by more

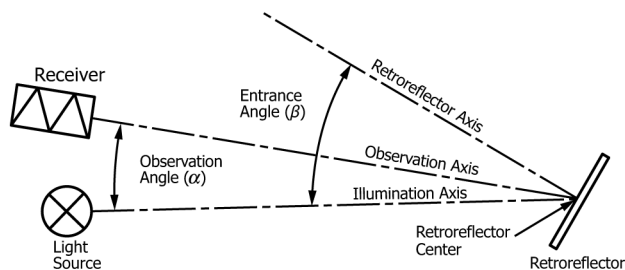

NOTE 1—This figure illustrates a simple test geometry for which the entrance half-plane and the observation half-plane are coplanar. In the CIE (goniometer) system this corresponds to the condition β₂ = 0°. The entrance angle β and the observation angle α are always positive. The figure does not show the rotation angle ε. In the CIE (goniometer) system, β would be labelled β₁ and shown with a single arrow ending at the retroreflector axis, and in this figure β₁ would be positive.

FIG. 3 Coplanar Test Configuration

than $\pm 5\%$ from the mean. Background light from directions other than the projector exit aperture must be negligible (that is, less than 0.1%) relative to the incident illuminance.

10.3 Return the receiver or light source to the observation position with entrance aperture separated at the appropriate distance from the source exit aperture to obtain the desired observation angle.

10.4 Position the test specimen to the desired entrance angle.

10.4.1 *Discussion*—For this coplanar geometry test method, it is strictly sufficient to specify a single value for the entrance angle. According to the method, that value will be set for entrance angle component β_1 , and entrance angle component β_2 will be set to zero. ASTM recommends that the test specifier provides explicit values β_1 and β_2 , even when $\beta_2 = 0^\circ$.

10.5 Position the receiver so that the sample, when it is placed on the holder, will be centered and entirely inside the receiver's field of view. With a black surface substituted for the test specimen, measure the background light level m_b .

10.6 Now replace the black surface with the test specimen and record the first retroreflected light reading (see 8.3 when datum mark is used). Make linearity corrections to this reading if required and record as m_1 .

10.7 Rotation angle. In this test method, the setting of the rotation angle, ϵ , determines both the rotation angle, ϵ , and the orientation angle, ω_s and may influence the results of measurements. The rotation angle is changed by rotating the specimen about its own (retroreflector) axis relative to a fixed starting position. The datum mark may be provided at the time of sampling or may be implied by the production process. In some cases the datum mark is indicated directly on the material at time of manufacture. See Section 7. A 0° rotation angle is with the datum axis in the observation half-plane. The starting position is determined and indicated in Fig. 1 where it is to the right. It can be in any position as determined by the equipment configuration.

10.7.1 If no rotation angle is specified, the measurement is taken at rotation angles of 0° and 90° and the average of these two values is recorded as m_1 .

10.7.2 If a rotation angle is specified, the measurement is made at that rotation and the value recorded as m_1 . A specified rotation angle usually implies that the retroreflective material is designed to be applied in a particular orientation.

10.7.3 If the material is known to be rotationally uniform in retroreflectance, for example, glass bead optics, a single measurement of the reflected light m_1 may be all that is required. With rotational uniformity, no datum mark is needed.

10.7.4 If no rotation angle is specified, and no means of establishing a datum mark is available as by 7.2.1, it may be necessary to measure the retroreflectance at 15° intervals from 0° to 345° (24 measurements of m_1) and either record the average m_1 or lowest m_1 as required by the end user.

10.7.5 For interlaboratory test comparisons, materials with datum marks have been tested at rotation angles of 0 and 90 degrees and the average of these two values recorded as m_1 . (See Section 13, which reports results of this test method.)

10.8 Rotate the sample holder to other entrance angles as required and repeat 10.6 and 10.7.

10.9 If additional observation angles are required, move the receiver to the next position desired and repeat 10.6 – 10.8. This will result in a series of m_b and m_1 readings for the first specimen. Follow the same procedure for testing additional specimens.

10.10 When the series of retroreflected light readings has been completed, take four additional incident light readings in accordance with 10.2. The average of the four initial readings when compared to the four final readings, should not differ by more than 1% . Average all eight readings, correct for linearity if required, and record as m_2 .

10.11 Using measuring instruments suitable to provide a minimum accuracy of $\pm 0.5\%$ in the result, measure the area of the actual effective retroreflective surface of the test sample in units of square metres. Record this as A .

11. Calculation

11.1 For each specimen and each combination of entrance and observation angles, calculate the coefficient of retroreflection of the retroreflective sheeting using the following equation:

$$R_A = [(m_1 - m_b)d^2/m_2A]$$

where:

- R_A = coefficient of retroreflection, in candelas per lux per square metre,
- m_b = background reading,
- m_1 = reading of retroreflective test specimen measured at observation position,
- m_2 = mean reading of source measured normal to the source at the specimen position,
- d = test distance, in metres, and
- A = area of samples, in square metres.

11.2 Average the R_A values for each set of three specimens representing each roll or batch, at each set of angle combinations. These average values are to be reported, and used to determine conformance to specification requirements.

12. Report

12.1 The report shall contain the following:

12.1.1 Sample identification.

12.1.2 Average value of the coefficient of retroreflection for each combination of entrance and observation angles.

12.1.3 Any deviation from the requirements stated in this test method.

13. Precision and Bias

13.1 The calculations, results, and terminology used to prepare this statement follow Practice E691. There are three parameters which must be considered when analyzing the precision of a measurement of coefficient of retroreflection. They are the level or magnitude of the measurement, the spectral quality or color of the sample, and the geometry or observation angle (α) and the entrance angle (β_T).

13.2 The number of laboratories included is six. Each laboratory measured each material four times. These four measurements were made on at least two different days. There are 14 different materials. Calculations were made for six different geometries.

13.1 *Precision*—The means precision of this test method is based on an interlaboratory study of ASTM E810 for each geometry and color are given, Test Method for Coefficient of Retroreflection of Retroreflective Sheeting Utilizing the Coplanar Geometry, conducted in Table 1. The values 2019. Each of ten volunteer laboratories were asked to test 24 different materials. Identification of the samples tested is in Table 1 indicate the magnitude of coefficient of retroreflection. The estimated standard deviations within laboratories are given in. Every “test result” represents an individual determination, and all participants were instructed to report four replicate Table 2. They are essentially averages test results for each material. Table 3 contains Practice E691 the estimates of between laboratory precision. This table contains estimates of a combination of the within- and between-laboratory component of was followed for the design and analysis of the data; the details are given in ASTM Research Report No. E12-2000, variance.⁴The reproducibilities of test results including both within- and between-laboratory variability are indicated by the coefficient of variation in Table 4. These values are given as percentages. The 95 % repeatability intervals are given in Table 5. They indicate the maximum permissible difference due to test error for two test results on the same material in a given laboratory to a 95 % probability level. The 95 % reproducibility intervals are listed in Table 6. Analogous to the repeatability interval, they indicate the maximum permissible difference between different laboratories for the same material at the 95 % probability level.

13.1.1 *Repeatability Limit (r)*—The difference between repetitive results obtained by the same operator in a given laboratory

⁴ Supporting data have been filed at ASTM International Headquarters and may be obtained by requesting Research Report RR:E12-2000. Contact ASTM Customer Service at service@astm.org.

TABLE 1 Coefficient of Retroreflection—Mean Values, R_A for Various Observation and Entrance Angles

	0.2, -4	0.2, +30	0.5, -4	0.5, +30	2.0, -4	2.0, +30
Engineering-Grade Sheeting α, β_1^A						
White	99.0	67.6	49.1	42.1	9.4	7.9
Yellow	73.8	36.3	35.4	22.9	5.0	4.3
Red	30.4	15.0	16.7	10.2	2.2	1.7
Blue	10.3	7.1	4.4	3.8	1.1	0.8
Green	14.4	7.7	7.7	4.7	1.4	1.1
Orange	34.8	16.9	20.1	11.7	2.6	2.0
High-Intensity Grade Sheeting α, β_1^A						
White	305.4	270.3	111.1	106.0	7.3	5.7
Yellow	214.2	179.5	86.8	80.4	4.9	3.9
Red	51.0	41.8	19.6	17.9	1.5	1.1
Blue	26.2	21.8	9.7	8.5	0.5	0.4
Green	64.0	54.0	24.2	22.4	1.2	1.0
Orange	109.4	92.6	42.7	40.0	3.2	2.6
Microprism Sheeting α, β_1^A						
White	309.3	97.9	243.7	52.9	11.8	4.8
Blue	61.7	22.0	52.0	11.5	2.5	1.1

^A Candela/sq. meter.

TABLE 2 Coefficient of Retroreflection, R_A Estimated Standard Deviation Within Laboratories

	0.2, -4	0.2, +30	0.5, -4	0.5, +30	2.0, -4	2.0, +30
Engineering-Grade Sheeting α, β_1^A						
White	1.84	1.40	1.10	0.72	0.34	0.13
Yellow	0.93	0.63	0.46	0.38	0.10	0.11
Red	0.58	0.25	0.23	0.16	0.08	0.08
Blue	0.23	0.15	0.11	0.14	0.06	0.03
Green	0.31	0.18	0.19	0.09	0.05	0.03
Orange	0.52	0.35	0.33	0.19	0.09	0.07
High-Intensity Grade Sheeting α, β_1^A						
White	4.08	3.86	1.36	1.54	0.34	0.31
Yellow	2.62	2.28	0.93	1.00	0.07	0.08
Red	0.37	0.34	0.22	0.21	0.05	0.06
Blue	0.62	0.33	0.14	0.15	0.14	0.04
Green	0.82	1.32	0.28	0.34	0.04	0.05
Orange	0.97	0.85	0.53	0.41	0.06	0.05
Microprism Sheeting α, β_1^A						
White	5.18	1.94	7.29	0.80	0.41	0.12
Blue	0.92	0.60	1.82	0.41	0.08	0.05

^A Candela/sq. meter.

TABLE 3 Coefficient of Retroreflection, R_A Estimate of Between Laboratory Precision, Standard Deviation

	0.2, -4	0.2, +30	0.5, -4	0.5, +30	2.0, -4	2.0, +30
Engineering-Grade Sheeting α, β_1^A						
White	4.60	2.50	3.45	2.06	0.38	0.27
Yellow	3.19	1.66	1.76	1.15	0.24	0.22
Red	1.84	0.99	0.61	0.47	0.12	0.11
Blue	1.36	0.94	0.71	0.59	0.17	0.12
Green	1.67	0.91	1.04	0.65	0.19	0.14
Orange	1.19	0.72	0.71	0.41	0.15	0.11
High-Intensity Grade Sheeting α, β_1^A						
White	6.74	7.31	4.57	4.37	0.43	0.35
Yellow	6.23	5.27	2.19	2.00	0.22	0.15
Red	3.82	3.06	0.89	0.79	0.05	0.06
Blue	2.77	2.39	1.40	1.17	0.20	0.11
Green	7.33	6.35	3.34	3.09	0.20	0.16
Orange	7.34	5.52	2.31	1.83	0.13	0.11
Microprism Sheeting α, β_1^A						
White	10.55	3.27	20.76	1.89	0.67	0.27
Blue	4.96	1.71	8.93	1.42	0.25	0.16

^A Candela/sq. meter.

TABLE 4 Reproducibility Between Laboratories Coefficient of Variation in R_A Percent ($p = 6$)

	0.2, -4	0.2, +30	0.5, -4	0.5, +30	2.0, -4	2.0, +30
Engineering-Grade Sheeting α, β_1						
White	4.7%	3.7%	7.2%	4.9%	4.0%	3.4%
Yellow	4.3	4.6	5.0	5.0	4.8	5.0
Red	6.1	6.6	3.7	4.6	5.5	6.1
Blue	13.2	13.2	15.9	15.5	16.1	14.2
Green	11.6	11.9	13.6	13.8	13.9	12.9

	0.2, -4	0.2, +30	0.5, -4	0.5, +30	2.0, -4	2.0, +30
Orange	-3.4	-4.2	-3.5	-3.5	-5.8	-5.4
High-Intensity Grade Sheeting α, β_T						
White	-2.2%	-2.7%	-4.1%	-4.1%	-5.8%	-6.1%
Yellow	-2.9	-2.9	-2.5	-2.5	-4.4	-3.8
Red	-7.5	-7.3	-4.5	-4.4	-3.1	-4.9
Blue	10.6	10.9	14.3	13.8	36.5	29.6
Green	11.4	11.7	13.8	13.8	16.3	16.2
Orange	-6.7	-6.0	-5.4	-4.6	-4.2	-4.4
Microprism Sheeting α, β						
White	-3.4%	-3.3%	-8.5%	-3.6%	-5.6%	-5.5%
Blue	-8.0	-7.8	17.2	12.3	10.0	14.7

TABLE 5 Coefficient of Retroreflection, R_A , 95 % Repeatability Interval (Within Laboratories)

	0.2, -4	0.2, +30	0.5, -4	0.5, +30	2.0, -4	2.0, +30
Engineering Grade Sheeting α, β_T^A						
White	-5.21	-3.96	-3.13	2.05	0.97	0.37
Yellow	-2.64	-1.79	-1.30	1.08	0.28	0.32
Red	-1.64	-0.71	-0.65	0.46	0.23	0.22
Blue	-0.66	-0.43	-0.33	0.41	0.17	0.09
Green	-0.89	-0.50	-0.53	0.25	0.13	0.08
Orange	-1.46	-0.98	-0.92	0.54	0.26	0.20
High-Intensity Grade Sheeting α, β_T^A						
White	11.53	10.92	-3.85	4.37	0.98	0.88
Yellow	-7.43	-6.47	-2.63	2.84	0.20	0.21
Red	-1.04	-0.95	-0.61	0.59	0.13	0.16
Blue	-1.76	-0.93	-0.38	0.44	0.40	0.13
Green	-2.32	-3.75	-0.79	0.96	0.11	0.13
Orange	-2.74	-2.40	-1.49	1.16	0.17	0.14
Microprism Sheeting α, β^A						
White	14.67	-5.49	20.63	2.27	1.16	0.34
Blue	-2.61	-1.69	-5.14	1.17	0.24	0.14

^A Candela Lux/square meter.

TABLE 6 Coefficient of Retroreflection, R_A , 95 % Reproducibility Interval, Between Laboratories

	0.2, -4	0.2, +30	0.5, -4	0.5, +30	2.0, -4	2.0, +30
Engineering Grade Sheeting α, β_T^A						
White	13.01	-7.07	-9.76		-5.83	1.07 0.77
Yellow	-9.04	-4.70	-4.98		-3.27	0.69 0.61
Red	-5.22	-2.81	-1.74		-1.33	0.34 0.30
Blue	-3.84	-2.66	-2.00		-1.67	0.49 0.33
Green	-4.72	-2.58	-2.95		-1.84	0.54 0.40
Orange	-3.37	-2.04	-2.01		-1.15	0.43 0.31
High Intensity Grade Sheeting α, β_T^A						
White	19.09	20.69	12.94		12.38	1.20 0.99
Yellow	17.62	14.90	-6.20		-5.68	0.61 0.43
Red	10.80	-8.67	-2.51		-2.24	0.13 0.16
Blue	-7.83	-6.76	-3.95		-3.32	0.56 0.33
Green	20.73	17.96	-9.44		-8.73	0.58 0.44
Orange	20.77	15.63	-6.54		-5.17	0.38 0.32
Microprism Sheeting α, β^A						
White	29.85	-9.24	58.75		-5.35	1.89 0.76
Blue	14.05	-4.85	25.28		-4.02	0.70 0.47

TABLE 1 Sample Identification

Sample	Type	Color	Description
1	III	White	Encapsulated Glassbead
2	III	Yellow	Encapsulated Glassbead
3	III	Orange	Encapsulated Glassbead
4	III	Green	Encapsulated Glassbead
5	III	Red	Encapsulated Glassbead
6	III	Blue	Encapsulated Glassbead
7	IV	Fl Orange	Microprismatic
8	IV	Fl Yellow-Green	Microprismatic
9	IV	White	Microprismatic