



Designation: ~~C1002—18~~ C1002 – 20

## Standard Specification for Steel Self-Piercing Tapping Screws for Application of Gypsum Panel Products or Metal Plaster Bases to Wood Studs or Steel Studs<sup>1</sup>

This standard is issued under the fixed designation C1002; the number immediately following the designation indicates the year of original adoption or, in the case of revision, the year of last revision. A number in parentheses indicates the year of last reapproval. A superscript epsilon ( $\epsilon$ ) indicates an editorial change since the last revision or reapproval.

### 1. Scope\*Scope

1.1 This specification covers steel self-piercing tapping screws for use in fastening gypsum panel products and metal plaster bases to cold-formed steel studs less than 0.033 in. (0.84 mm) in thickness and wood members, and for fastening gypsum panel products to gypsum board.

1.2 This specification also covers test methods for determining performance requirements and physical properties.

1.3 The values stated in inch-pound units are to be regarded as standard. The SI (metric) values given in parentheses are ~~approximate and are for information only.~~ mathematical conversions to SI units that are provided for information only and are not considered standard.

1.4 The following safety hazards caveat pertains only to the test methods described in this specification: *This standard does not purport to address all of the safety concerns, if any, associated with its use. It is the responsibility of the user of this standard to establish appropriate safety, health, and environmental practices and determine the applicability of regulatory limitations prior to use.*

1.5 *This international standard was developed in accordance with internationally recognized principles of standardization established in the Decision on Principles for the Development of International Standards, Guides and Recommendations issued by the World Trade Organization Technical Barriers to Trade (TBT) Committee.*

### 2. Referenced Documents

#### 2.1 ASTM Standards:<sup>2</sup>

- [A510/A510M Specification for General Requirements for Wire Rods and Coarse Round Wire, Carbon Steel, and Alloy Steel](#)
- [A1040 Guide for Specifying Harmonized Standard Grade Compositions for Wrought Carbon, Low-Alloy, and Alloy Steels](#)
- [C11 Terminology Relating to Gypsum and Related Building Materials and Systems](#)
- [C475/C475M Specification for Joint Compound and Joint Tape for Finishing Gypsum Board](#)
- [C645 Specification for Nonstructural Steel Framing Members](#)
- [C847 Specification for Metal Lath](#)
- [C1396/C1396M Specification for Gypsum Board](#)

<sup>1</sup> This specification is under the jurisdiction of ASTM Committee C11 on Gypsum and Related Building Materials and Systems and is the direct responsibility of Subcommittee C11.02 on Specifications and Test Methods for Accessories and Related Products.

Current edition approved April 1, 2018; Oct. 1, 2020. Published April 2018; November 2020. Originally approved in 1983. Last previous edition approved in 2016 as ~~C1002—16~~ C1002 – 18. DOI: 10.1520/C1002-18; 10.1520/C1002-20.

<sup>2</sup> For referenced ASTM standards, visit the ASTM website, www.astm.org, or contact ASTM Customer Service at service@astm.org. For *Annual Book of ASTM Standards* volume information, refer to the standard's Document Summary page on the ASTM website.

\*A Summary of Changes section appears at the end of this standard

### 3. Terminology

#### 3.1 Definitions:

3.1.1 For definitions relating to gypsum and related building materials and systems, see Terminology **C11**. For definitions relating to gypsum and related building materials and systems, see Terminology **CH**.

#### 3.2 Definitions:

#### 3.3 Definitions of Terms Specific to This Standard:

3.3.1 *self-piercing, v=adj*—the ability to penetrate without benefit of a pre-drilled hole with sharp-point angles of not more than 30°.

### 4. Classification

4.1 Steel screws covered by this specification are of four types of thread configurations:

4.1.1 *Type G*, ~~course-pitch~~coarse-pitch high-thread self-piercing screws for fastening gypsum board to gypsum board.

4.1.2 *Type S*, fine-thread screw for fastening gypsum board to cold formed steel members.

4.1.3 *Type W*, ~~course-thread~~coarse-thread screw for fastening gypsum board to wood members.

4.1.4 *Type A*, ~~course-pitch~~coarse-pitch tapping screw thread for fastening metal plaster bases to wood or cold-formed steel.

### 5. Materials

5.1 Screws shall be made from steel wire manufactured in accordance with Specification **A510/A510M**.

5.1.1 Chemical composition for Type G and Type W screws shall be in accordance with Specification **A1040**, Grade 1013 to 1022.

5.1.2 Chemical composition for Type S and Type A screws shall be in accordance with Specification **A1040**, Grade 1018 to 1022.

### 6. Physical Properties

#### 6.1 Hardness:

6.1.1 The surface of Type S, Type W, and Type A screws shall be case hardened to a depth of not less than 0.002 in. (0.05 mm) with case hardness not less than 45 HRC.

6.1.2 The surface of Type G screws is not required to be case hardened.

6.2 *Ductility*—The screws shall have sufficient ductility to be able to withstand a 10° bend without visible signs of fracture when tested as specified in **12.6.7**.

### 7. Performance Requirements

#### 7.1 Type G Screws:

7.1.1 Screws shall be able to self-pierce and drive into gypsum panel products.

7.1.2 Screw threads shall be adequate to pull the head of the screw below the surface of the gypsum panel product when tested as specified in **12.6.2**.

#### 7.2 Type S Screws:

7.2.1 *General*—Screws shall be able to self-pierce and drive into cold-formed steel members in less than 2 s, when tested as specified in **12.6.3.1**.

7.2.2 *Screws for Fastening Gypsum Panel Products*—Screw threads shall be adequate to pull the head of the screw below the surface of the gypsum panel product, without spin-out, when tested as specified in 12.6.3.

### 7.3 *Type W Screws:*

7.3.1 *General*—Screw threads shall be able to self-pierce and drive into wood members.

7.3.2 *Screws for Fastening Gypsum Panel Products*—Screw threads shall be adequate to pull the head of the screw below the surface of the gypsum panel product, without spin-out, when tested as specified in 12.6.6.

### 7.4 *Type A Screws:*

7.4.1 *General*—Screw shall be able to pierce and drive into wood or cold-formed steel members.

7.4.2 *Screws for Fastening Metal Plaster Bases*—Screw threads shall be adequate to pull a metal plaster base tightly enough against the face of a wood or steel stud, without spin-out, so that when subjected to a steady pull, the plaster base will tear before slipping out from under the screw head, when tested in accordance with 12.6.4 or 12.6.5.

## 8. Dimensions and Permissible Variations

### 8.1 *Head Diameter:*

8.1.1 *General*—Heads shall be permitted to be out of round not more than 0.02 in. (0.51 mm).

8.1.2 *Screws for Fastening Gypsum Board*—Not less than 0.315 in. (8 mm).

8.1.3 *Screws for Fastening Metal Plaster Bases*—Not less than 0.437 in. (11.1 mm).

### 8.2 *Head Contour:*

8.2.1 *Screws for Fastening Gypsum Panel Products*—The top of the head shall be flat. The outer flange thickness shall be  $0.025 \pm 0.005$  in. ( $0.64 \pm 0.13$  mm). The contour beneath the flange head shall be such that the screw head shall be able to be driven so that the head of the screw rests immediately below the surface of the gypsum panel product.

8.2.2 *Screws for Fastening Metal Plaster Bases*—The top of the screw shall be either flat or contoured. The underside of the head shall be flat or near flat. The threads shall extend to the underside of the head.

### 8.3 *Driving Recess:*

8.3.1 *Screws for Fastening Gypsum Board*—No. 2 “Phillips” design, depth of recess, not less than 0.104 in. (2.64 mm).

8.3.2 *Screws for Fastening Metal Plaster Bases*—No. 2 “Phillips” design, depth of recess, not less than 0.077 in. (1.95 mm).

8.3.3 Determine depth of recess with a Phillips penetration depth gauge.

8.3.4 Other types of screw-driving recesses having performance values equal to those of the recesses specified are acceptable.

8.4 *Shank Diameter*—Not less than No. 6, with major diameter not less than 0.136 in. (3.45 mm).

### 8.5 *Length:*

8.5.1 *Nominal Length*—The nominal length shall be the minimum length.

8.5.2 Type W and Type A screws shall be long enough to penetrate wood members not less than  $\frac{5}{8}$  in. (15.9 mm).

8.6 *Threads*—Either single or multiple thread design.

8.7 *Points*—Self-piercing design.

## 9. Finish and Appearance

9.1 *Form*—The form shall be straight and neatly formed.

9.2 *Threads*—The threads shall be clean and smooth.

9.3 *Finish*—Screws shall have a corrosion-resistant treatment. The treatment shall not inhibit adhesion to finishing compounds nor bleed through field-applied decoration.

## 10. Sampling

10.1 Obtain not less than 90 screws from not less than five containers.

## 11. Number of Tests and Retests

11.1 Test a minimum of five screws for each test. If any of the first lot fails, test 25 more screws.

11.2 If two or more of the second lot fail the second test, then the represented lot fails to meet the specified requirements.

## 12. Test Methods

12.1 The following test methods set forth procedures used to determine the ability of the screws to pierce through gypsum panel and metal plaster base and into the backup material without spin-out.

12.1.1 ~~The~~These test methods can also be used to determine whether or not alternate screw driving recesses will have performance values equal to those of the “Phillips” recess specified.

12.2 *Significance and Use*—~~The~~These test methods provide procedures for evaluating the physical properties and performance requirements of steel self-piercing screws. The degree of correlation between these tests and service performance has not been determined.

12.3 *Apparatus Shall Satisfy the Following:*

12.3.1 ~~Power-Driven~~Power driven Drill Screw Gun, capable of 4000 rpm (free spindle speed) with a depth-sensitive nose piece, supplied with a screw driving bit to fit the screw used in the test.

12.3.2 *Stop Watch*, capable of being read to the nearest 0.1 s.

12.3.3 *Vice*—Standard machinists vice, not less than 3 in. (76 mm).

12.3.4 *Clamp*—Locking pliers (“Vice-Grip”), 6 in. (152 mm).

12.4 *Materials:*

12.4.1 *Gypsum Wallboard*—Specification C1396/C1396M, Type X, 5/8 in. (16 mm) thick.

12.4.2 *Metal Lath*—Specification C847, diamond mesh, weight 2.5 lb/yd<sup>2</sup> (1.4 kg/m<sup>2</sup>).

12.4.3 *Steel Stud*—Specification C645, 0.0179 in. (0.455 mm) thick, hardness not less than 52 HRB, size 35/8 in. (92.1 mm).

12.4.4 *Wood Stud*—Douglas fir, construction grade, 2 by 4 or 2 by 6, nominal, containing not less than 16 % nor more than 19 % free moisture as determined by a suitable moisture meter.

12.4.5 *Paper Joint Tape*—Specification C475/C475M.

12.5 *Specimen Preparation:*

12.5.1 For each test, one piece of gypsum wallboard, 6 in. (150 mm) square, shall be cut from not less than 12 in. (300 mm) from the edge or end of the gypsum wallboard.

12.5.2 For each test, one piece of 6 in. (150 mm) square specimen shall be cut from a sheet of metal lath not less than 4 in. (100 mm) away from the edge or end.

12.5.3 Each member to be tested shall be cut into test specimens not less than 18 in. (460 mm) long.

12.6 *Procedure:*

12.6.1 *General*—Drive the screws not closer than 5/8 in. (16 mm) from the edges of the gypsum wallboard and not closer than 2 in. (50 mm) from the edges of the metal lath.

12.6.2 *Type G Screw Test*—Rigidly support two pieces of gypsum board sandwiched together. With a screw gun, drive the screw specimen into the gypsum boards, so that the head of the screw is below the surface of the gypsum board.

12.6.2.1 When driving Type G screw specimens, use the force of less than 20 lbf (89 N).

12.6.2.2 *Interpretation of Results*—Observe if the screws are pulled below the surface of the gypsum board. If any of the five screws fail, the lot has failed the test. Retest in accordance with Section 11.

12.6.2.3 *Report*—Report whether the lot has passed or failed the test.

12.6.2.4 *Precision and Bias*—No information is presented about either the precision or the bias for the Type G screw test for pulling the screw head below the surface of the gypsum board, because the test result is non-quantitative.

12.6.3 *Type “S” Screws Test for Fastening Board to Steel:*

12.6.3.1 Assemble the member, gypsum wallboard, and paper joint tape on a rigid, flat surface. (See Fig. 1 for studs.)

12.6.3.2 Prior to performing the test, drive several screws without the paper joint tape to set the depth of the nose piece on the screw gun, allowing the screws to be driven below the surface of the wallboard without breaking the gypsum wallboard face paper.

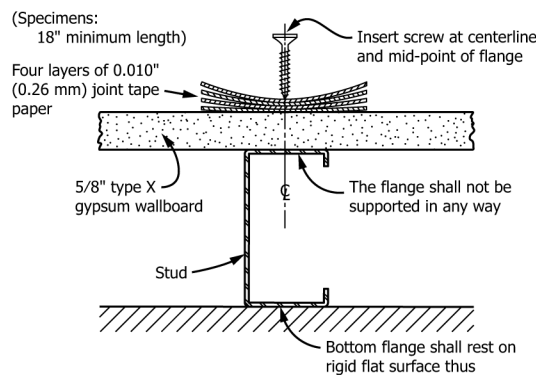

FIG. 1 Studs

NOTE 1—Wallboard specimens shall be taken a minimum of 12 in. (305 mm) from either edge and either end of wallboard panel.