

INTERNATIONAL STANDARD

NORME INTERNATIONALE



Semiconductor devices –
Part 16-4: Microwave integrated circuits – Switches

Dispositifs à semiconducteurs –
Partie 16-4: Circuits intégrés hyperfréquences – Commutateurs

IEC 60747-16-4:2004

<https://standards.iteh.ai/catalog/standards/iec/f591469a-b7f7-4c47-8ac3-8f237f5aace3/iec-60747-16-4-2004>





THIS PUBLICATION IS COPYRIGHT PROTECTED
Copyright © 2017 IEC, Geneva, Switzerland

All rights reserved. Unless otherwise specified, no part of this publication may be reproduced or utilized in any form or by any means, electronic or mechanical, including photocopying and microfilm, without permission in writing from either IEC or IEC's member National Committee in the country of the requester. If you have any questions about IEC copyright or have an enquiry about obtaining additional rights to this publication, please contact the address below or your local IEC member National Committee for further information.

Droits de reproduction réservés. Sauf indication contraire, aucune partie de cette publication ne peut être reproduite ni utilisée sous quelque forme que ce soit et par aucun procédé, électronique ou mécanique, y compris la photocopie et les microfilms, sans l'accord écrit de l'IEC ou du Comité national de l'IEC du pays du demandeur. Si vous avez des questions sur le copyright de l'IEC ou si vous désirez obtenir des droits supplémentaires sur cette publication, utilisez les coordonnées ci-après ou contactez le Comité national de l'IEC de votre pays de résidence.

IEC Central Office
3, rue de Varembe
CH-1211 Geneva 20
Switzerland

Tel.: +41 22 919 02 11
info@iec.ch
www.iec.ch

About the IEC

The International Electrotechnical Commission (IEC) is the leading global organization that prepares and publishes International Standards for all electrical, electronic and related technologies.

About IEC publications

The technical content of IEC publications is kept under constant review by the IEC. Please make sure that you have the latest edition, a corrigendum or an amendment might have been published.

IEC publications search - webstore.iec.ch/advsearchform

The advanced search enables to find IEC publications by a variety of criteria (reference number, text, technical committee,...). It also gives information on projects, replaced and withdrawn publications.

IEC Just Published - webstore.iec.ch/justpublished

Stay up to date on all new IEC publications. Just Published details all new publications released. Available online and once a month by email.

IEC Customer Service Centre - webstore.iec.ch/csc

If you wish to give us your feedback on this publication or need further assistance, please contact the Customer Service Centre: sales@iec.ch.

Electropedia - www.electropedia.org

The world's leading online dictionary on electrotechnology, containing more than 22 000 terminological entries in English and French, with equivalent terms in 16 additional languages. Also known as the International Electrotechnical Vocabulary (IEV) online.

IEC Glossary - std.iec.ch/glossary

67 000 electrotechnical terminology entries in English and French extracted from the Terms and definitions clause of IEC publications issued between 2002 and 2015. Some entries have been collected from earlier publications of IEC TC 37, 77, 86 and CISPR.

A propos de l'IEC

La Commission Electrotechnique Internationale (IEC) est la première organisation mondiale qui élabore et publie des Normes internationales pour tout ce qui a trait à l'électricité, à l'électronique et aux technologies apparentées.

A propos des publications IEC

Le contenu technique des publications IEC est constamment revu. Veuillez vous assurer que vous possédez l'édition la plus récente, un corrigendum ou amendement peut avoir été publié.

Recherche de publications IEC - webstore.iec.ch/advsearchform

La recherche avancée permet de trouver des publications IEC en utilisant différents critères (numéro de référence, texte, comité d'études,...). Elle donne aussi des informations sur les projets et les publications remplacées ou retirées.

IEC Just Published - webstore.iec.ch/justpublished

Restez informé sur les nouvelles publications IEC. Just Published détaille les nouvelles publications parues. Disponible en ligne et une fois par mois par email.

Service Clients - webstore.iec.ch/csc

Si vous désirez nous donner des commentaires sur cette publication ou si vous avez des questions contactez-nous: sales@iec.ch.

Electropedia - www.electropedia.org

Le premier dictionnaire d'électrotechnologie en ligne au monde, avec plus de 22 000 articles terminologiques en anglais et en français, ainsi que les termes équivalents dans 16 langues additionnelles. Egalement appelé Vocabulaire Electrotechnique International (IEV) en ligne.

Glossaire IEC - std.iec.ch/glossary

67 000 entrées terminologiques électrotechniques, en anglais et en français, extraites des articles Termes et définitions des publications IEC parues entre 2002 et 2015. Plus certaines entrées antérieures extraites des publications des CE 37, 77, 86 et CISPR de l'IEC.



IEC 60747-16-4

Edition 1.2 2017-08
CONSOLIDATED VERSION

INTERNATIONAL STANDARD

NORME INTERNATIONALE



**Semiconductor devices –
Part 16-4: Microwave integrated circuits – Switches**

**Dispositifs à semiconducteurs –
Partie 16-4: Circuits intégrés hyperfréquences – Commutateurs**

[IEC 60747-16-4:2004](https://standards.iteh.ai/catalog/standards/iec/f591469a-b7f7-4c47-8ac3-8f237f5aaee3/iec-60747-16-4-2004)

<https://standards.iteh.ai/catalog/standards/iec/f591469a-b7f7-4c47-8ac3-8f237f5aaee3/iec-60747-16-4-2004>

INTERNATIONAL
ELECTROTECHNICAL
COMMISSION

COMMISSION
ELECTROTECHNIQUE
INTERNATIONALE

ICS 31.080.99

ISBN 978-2-8322-8955-6

**Warning! Make sure that you obtained this publication from an authorized distributor.
Attention! Veuillez vous assurer que vous avez obtenu cette publication via un distributeur agréé.**

REDLINE VERSION

VERSION REDLINE



Semiconductor devices –
Part 16-4: Microwave integrated circuits – Switches

Dispositifs à semiconducteurs –
Partie 16-4: Circuits intégrés hyperfréquences – Commutateurs

IEC 60747-16-4:2004

<https://standards.iteh.ai/catalog/standards/iec/f591469a-b7f7-4c47-8ac3-8f237f5aace3/iec-60747-16-4-2004>

CONTENTS

FOREWORD 3

1 Scope 5

2 Normative references 5

3 Terms and definitions 6

4 Essential ratings and characteristics 7

 4.1 Circuit identification and types 7

 4.2 Application description 8

 4.3 Specification of the function 9

 4.4 Limiting values (absolute maximum rating system) 10

 4.5 Operating conditions (within the specified operating temperature range) 11

 4.6 Electrical characteristics 12

 4.7 Mechanical and environmental ratings, characteristics and data 12

 4.8 Additional information 12

5 Measuring methods 13

 5.1 General 13

 5.2 Insertion loss (L_{ins}) 14

 5.3 Isolation (L_{iso}) 16

 5.4 Return loss (L_{ret}) 17

 5.5 Input power at 1 dB compression ($P_{i(1dB)}$) and output power at 1 dB
compression ($P_{o(1dB)}$) 19

 5.6 Turn-on time (t_{on}), turn-off time (t_{off}), rise time ($t_{r(out)}$), and fall time ($t_{f(out)}$) 20

 5.7 Adjacent channel power ratio ~~$(P_{o(mod)}/P_{adj})$~~ ($P_{adj}/P_{o(mod)}$) 22

 5.8 n th order harmonic distortion ratio (P_{nth}/P_1) 25

Bibliography 26

Figure 1 – Circuit diagram for the measurement of the insertion loss L_{ins} 14

Figure 2 – Circuit diagram for the measurement of the isolation L_{iso} 16

Figure 3 – Circuit for the measurements of the return loss 17

Figure 4 – Circuit for the measurements of switching times 20

Figure 5 – Input and output waveforms 21

Figure 6 – Circuit for the measurement of the adjacent channel power ratio 23

Figure 7 – Circuit diagram for the n -th order harmonic distortion ratio 26

INTERNATIONAL ELECTROTECHNICAL COMMISSION

SEMICONDUCTOR DEVICES –

**Part 16-4: Microwave integrated circuits –
Switches**

FOREWORD

- 1) The International Electrotechnical Commission (IEC) is a worldwide organization for standardization comprising all national electrotechnical committees (IEC National Committees). The object of IEC is to promote international co-operation on all questions concerning standardization in the electrical and electronic fields. To this end and in addition to other activities, IEC publishes International Standards, Technical Specifications, Technical Reports, Publicly Available Specifications (PAS) and Guides (hereafter referred to as "IEC Publication(s)"). Their preparation is entrusted to technical committees; any IEC National Committee interested in the subject dealt with may participate in this preparatory work. International, governmental and non-governmental organizations liaising with the IEC also participate in this preparation. IEC collaborates closely with the International Organization for Standardization (ISO) in accordance with conditions determined by agreement between the two organizations.
- 2) The formal decisions or agreements of IEC on technical matters express, as nearly as possible, an international consensus of opinion on the relevant subjects since each technical committee has representation from all interested IEC National Committees.
- 3) IEC Publications have the form of recommendations for international use and are accepted by IEC National Committees in that sense. While all reasonable efforts are made to ensure that the technical content of IEC Publications is accurate, IEC cannot be held responsible for the way in which they are used or for any misinterpretation by any end user.
- 4) In order to promote international uniformity, IEC National Committees undertake to apply IEC Publications transparently to the maximum extent possible in their national and regional publications. Any divergence between any IEC Publication and the corresponding national or regional publication shall be clearly indicated in the latter.
- 5) IEC itself does not provide any attestation of conformity. Independent certification bodies provide conformity assessment services and, in some areas, access to IEC marks of conformity. IEC is not responsible for any services carried out by independent certification bodies.
- 6) All users should ensure that they have the latest edition of this publication.
- 7) No liability shall attach to IEC or its directors, employees, servants or agents including individual experts and members of its technical committees and IEC National Committees for any personal injury, property damage or other damage of any nature whatsoever, whether direct or indirect, or for costs (including legal fees) and expenses arising out of the publication, use of, or reliance upon, this IEC Publication or any other IEC Publications.
- 8) Attention is drawn to the Normative references cited in this publication. Use of the referenced publications is indispensable for the correct application of this publication.
- 9) Attention is drawn to the possibility that some of the elements of this IEC Publication may be the subject of patent rights. IEC shall not be held responsible for identifying any or all such patent rights.

This consolidated version of the official IEC Standard and its amendments has been prepared for user convenience.

IEC 60747-16-4 edition 1.2 contains the first edition (2004-07) [documents 47E/256/FDIS and 47E/261/RVD], its amendment 1 (2009-03) [documents 47E/358/CDV and 47E/373/RVC] and its amendment 2 (2017-08) [documents 47E/546/CDV and 47E/563/RVC].

In this Redline version, a vertical line in the margin shows where the technical content is modified by amendments 1 and 2. Additions are in green text, deletions are in strikethrough red text. A separate Final version with all changes accepted is available in this publication.

International Standard IEC 60747-16-4 has been prepared by subcommittee 47E: Discrete semiconductor devices, of IEC technical committee 47: Semiconductor devices.

This publication has been drafted in accordance with the ISO/IEC Directives, Part 2.

The committee has decided that the contents of the base publication and its amendments will remain unchanged until the stability date indicated on the IEC web site under "<http://webstore.iec.ch>" in the data related to the specific publication. At this date, the publication will be

- reconfirmed,
- withdrawn,
- replaced by a revised edition, or
- amended.

IMPORTANT – The “colour inside” logo on the cover page of this publication indicates that it contains colours which are considered to be useful for the correct understanding of its contents. Users should therefore print this publication using a colour printer.

iTeh Standards
(<https://standards.iteh.ai>)
Document Preview

[IEC 60747-16-4:2004](#)

<https://standards.iteh.ai/catalog/standards/iec/f591469a-b7f7-4c47-8ac3-8f237f5aace3/iec-60747-16-4-2004>

SEMICONDUCTOR DEVICES –

Part 16-4: Microwave integrated circuits – Switches

1 Scope

This part of IEC 60747 provides new measuring methods, terminology and letter symbols, as well as essential ratings and characteristics for integrated circuit microwave switches.

There are many combinations for RF ports in switches, such as SPST (single pole single throw), SPDT (single pole double throw), SP3T (single pole triple throw), DPDT (double pole double throw), etc. Switches in this standard are based on SPDT. However, this standard is applicable to the other types of switches.

2 Normative references

The following referenced documents are indispensable for the application of this document. For dated references, only the edition cited applies. For undated references, the latest edition of the referenced document (including any amendments) applies.

~~IEC 60617-12, Graphical symbols for diagrams – Part 12: Binary logic elements~~

~~IEC 60617-13, Graphical symbols for diagrams – Part 13: Analogue elements~~

IEC 60617, Graphical symbols for diagrams (available from <<http://std.iec.ch/iec60617>>)

~~IEC 60747-1(1983), Semiconductor devices – Discrete devices and integrated circuits – Part 1: General~~
~~Amendment 3 (1996)~~

IEC 60747-1:2006, Semiconductor devices – Part 1: General
IEC 60747-1:2006/AMD1:2010

IEC 60747-4, Semiconductor devices – Discrete devices – Part 4: Microwave devices

IEC 60747-16-1:2001, Semiconductor devices – Part 16-1: Microwave integrated circuits – Amplifiers

IEC 60747-16-1:2001/AMD1:2007

IEC 60747-16-1:2001/AMD2:2017

IEC 60748-2, Semiconductor devices – Integrated circuits – Part 2: Digital integrated circuits

IEC 60748-3, Semiconductor devices – Integrated circuits – Part 3: Analogue integrated circuits

IEC 60748-4, Semiconductor devices – Integrated circuits – Part 4: Interface integrated circuits

IEC 61340-5-1:2007, Electrostatics – Part 5-1: Protection of electronic devices from electrostatic phenomena – General requirements

IEC/TR 61340-5-2:2007, Electrostatics – Part 5-2: Protection of electronic devices from electrostatic phenomena – User guide

3 Terms and definitions

For the purposes of this document, the following terms and definitions apply.

Terms related to electrical characteristics

3.1

insertion loss

L_{ins}

ratio of the ~~out~~ input power to the output power at the switched on port, ~~to the input power~~ in the linear region of the power transfer curve P_O (dBm) = $f(P_i)$

NOTE 1 In this region, ΔP_O (dBm) = ΔP_i (dBm).

NOTE 2 Usually the insertion loss is expressed in decibels.

3.2

isolation

L_{iso}

ratio of the ~~out~~ input power to the output power at the switched off port, ~~to the input power~~ in the linear region of the power transfer curve P_O (dBm) = $f(P_i)$

NOTE 1 In this region, ΔP_O (dBm) = ΔP_i (dBm).

NOTE 2 Usually the isolation is expressed in decibels.

3.3

return loss

L_{ret}

ratio of the incident power P_{inc} at the specified port to the reflected power P_{ref} at the same port in the linear region of the power transfer curve P_{ref} (dBm) = $f(P_{inc})$

NOTE 1 In this region, ΔP_{ref} (dBm) = ΔP_{inc} (dBm).

NOTE 2 Usually the return loss is expressed in decibels.

3.4

input power at 1 dB compression

$P_{i(1dB)}$

input power where the insertion loss increases by 1 dB compared with insertion loss in linear region

3.5

output power at 1 dB compression

$P_{o(1dB)}$

output power where the insertion loss increases by 1 dB compared with insertion loss in linear region

3.6

turn on time

t_{on}

interval between the lower reference point on the leading edge of the control voltage and the upper reference point on the leading edge of the envelope of the output voltage in the linear region of the power transfer curve P_O (dBm) = $f(P_i)$

NOTE In this region, ΔP_O (dBm) = ΔP_i (dBm).

3.7

turn off time

t_{off}

interval between the upper reference point on the trailing edge of the control voltage and the lower reference point on the trailing edge of the envelope of the output voltage in the linear region of the power transfer curve P_O (dBm) = $f(P_i)$

NOTE In this region, ΔP_O (dBm) = ΔP_i (dBm).

3.8 rise time

$t_{r(out)}$

interval between the lower reference point on the leading edge of the output voltage and the upper reference point on the leading edge of the envelope of the output voltage in the linear region of the power transfer curve P_o (dBm) = $f(P_i)$

NOTE In this region, ΔP_o (dBm) = ΔP_i (dBm).

3.9 fall time

$t_{f(out)}$

interval between the upper reference point on the trailing edge of the output voltage and the lower reference point on the trailing edge of the envelope of the output voltage in the linear region of the power transfer curve P_o (dBm) = $f(P_i)$

NOTE In this region, ΔP_o (dBm) = ΔP_i (dBm).

3.10 adjacent channel power ratio

$P_{o(mod)}/P_{adj}$ $P_{adj}/P_{o(mod)}$

~~ratio of the total power in the specified carrier signal frequency band to total output power in the specified frequency band away from the specified carrier signal frequency, at the specified output power when the modulation signal is supplied~~

ratio of the total output power in a specified frequency band away from a specified carrier signal frequency to the total power in a specified carrier signal frequency band, when a modulation signal is supplied

[SOURCE: IEC 60747-16-1:2001/AMD2:2017, 3.21]

3.11 ~~n~~-nth order harmonic distortion ratio

P_{nth}/P_1

~~See 3.14 of Amendment 1 of IEC 60747-16-1(2001).~~

ratio of the power of the n th order harmonic component measured at the output port of the device to the power of the fundamental frequency measured at the output port

[SOURCE: IEC 60747-16-1:2001/AMD2:2017, 3.14]

4 Essential ratings and characteristics

This clause gives ratings and characteristics required for specifying integrated circuit microwave switches.

4.1 Circuit identification and types

4.1.1 Designation and types

Identification of type (device name), category of circuit and technology applied should be given. Microwave switches comprise one category.

4.1.2 General function description

A general description of the function performed by the integrated circuit microwave switches and the features for the application should be made.

4.1.3 Manufacturing technology

The manufacturing technology, e.g. semiconductor monolithic integrated circuit, thin film integrated circuit, micro-assembly, etc. should be stated. This statement should include details of the semiconductor technologies such as Schottky-barrier diode, PIN diode, MESFET, Si bipolar transistor, etc.

IEC 60747-4 should be referred to for terminology and letter symbols, essential ratings and characteristics and measuring methods of such microwave devices.

4.1.4 Package identification

The following statements should be made:

- a) chip or packaged form;
- b) IEC and/or national reference number of the outline drawing, ~~or~~ or drawing of non-standard package including terminal numbering;
- c) principal package material, for example, metal, ceramic, plastic.

4.1.5 Main application

The main application should be stated. If the device has restrictive applications, these should be stated here.

4.2 Application description

Information on application of the integrated circuit and its relation to the associated devices should be given.

4.2.1 Conformance to system and/or interface information

It should be stated whether the integrated circuit conforms to an application system and/or an interface standard or a recommendation. [60747-16-4:2004](https://standards.iteh.ai/catalog/standards/iec/60747-16-4-2004)

Detailed information concerning application systems, equipment and circuits such as VSAT systems, DBS receivers, microwave landing systems, etc. should also be given.

4.2.2 Overall block diagram

A block diagram of the applied systems should be given if necessary.

4.2.3 Reference data

The most important properties that permit comparison between derivative types should be given.

4.2.4 Electrical compatibility

It should be stated whether the integrated circuit is electrically compatible with other particular integrated circuits, or families of integrated circuits, or whether special interfaces are required.

Details should be given concerning the type of input and output circuits, e.g. input/output impedances, d.c. block, open-drain, etc. Interchangeability with other devices, if any, should also be given.

4.2.5 Associated devices

If applicable, the following should be stated:

- devices necessary for correct operation (list with type number, name and function);

- peripheral devices with direct interfacing (list with type number, name and function).

4.3 Specification of the function

4.3.1 Detailed block diagram – Functional blocks

A detail block diagram or equivalent circuit information of the integrated circuit microwave switches should be given. The block diagram should be composed of the following:

- functional blocks;
- mutual interconnections among the functional blocks;
- individual functional units within the functional blocks;
- mutual interconnections among the individual functional blocks;
- function of each external connection;
- inter-dependence between the separate functional blocks.

The block diagram should identify the function of each external connection and, where no ambiguity can arise, also show the terminal symbols and/or numbers. If the encapsulation has metallic parts, any connection to them from external terminals should be indicated. The connections with any associated external electrical elements should be stated, where necessary.

As additional information, the complete electrical circuit diagram can be reproduced, but not necessarily with indications of the values of the circuit components. The graphical symbol for the function shall be given. Rules governing such diagrams may be obtained from IEC 60617-12 or IEC 60617-13.

4.3.2 Identification and function of terminals

All terminals should be identified on the block diagram (supply terminals, input or output terminals, input/output terminals).

The terminal functions 1) to 4) should be indicated in a table as follows:

Terminal number	Terminal symbol	1) Terminal designation	2) Function	Function of terminal	
				3) Input/output identification	4) Type of input/output circuits

1) Terminal designation

A terminal designation to indicate the function of the terminal should be given. Supply terminals, ground terminals, blank terminals (with abbreviation NC), non-usable terminals (with abbreviation NU) should be distinguished.

2) Function

A brief indication of the terminal function should be given:

- each function of multi-role terminals, i.e. terminals having multiple functions;
- each function of integrated circuit selected by mutual pin connections, programming and/or application of function selection data to the function selection pin, such as mode selection pin.

3) Input/output identification

Input, output, input/output and multiplex input/output terminals should be distinguished.

4) Type of input/output circuits

The type of input and output circuit, e.g. input/output impedances, with or without d.c. block, etc., should be distinguished.

5) Type of ground

If the baseplate of the package is used as ground, this should be stated.

Example:

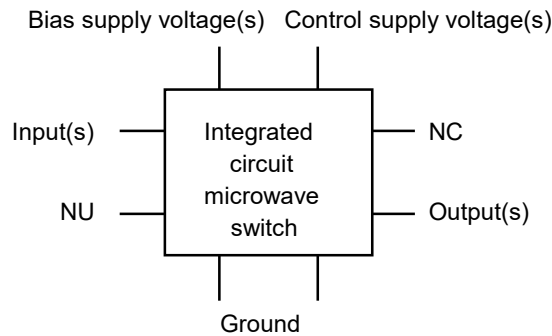

4.3.3 Function description

The function performed by the circuit should be specified, including the following information:

- basic function;
- relation to external terminals;
- operation mode (e.g., set-up method, preference, etc.);
- interrupt handling.

4.3.4 Family related characteristics

In this part, all the family specific functional descriptions shall be stated (referred to IEC 60748-2, IEC 60748-3 and IEC 60748-4).

If ratings and characteristics, as well as function characteristics exist for the family, the relevant part of IEC 60748 should be used (e.g. for microprocessors, see IEC 60748-2, Chapter III, Section Three).

IEC 60747-16-4:2004

NOTE For each new device family, specific items should be added the relevant part of IEC 60748. 60747-16-4-2004

4.4 Limiting values (absolute maximum rating system)

The table for these values should contain the following:

- Any interdependence of limiting conditions shall be specified.
- If externally connected and/or attached elements, for example heatsinks, have an influence on the values of the ratings, the ratings shall be prescribed for the integrated circuit with the elements connected and/or attached.
- If limiting values are exceeded for transient overload, the permissible excess and their durations shall be specified.
- Where minimum and maximum values differ during programming of the device, this should be stated.
- All voltages are referenced to a specified reference terminal (V_{SS} , ground, etc.).
- In satisfying the following clauses, if maximum and/or minimum values are quoted, the manufacturer shall indicate whether he refers to the absolute magnitude or to the algebraic value of the quantity.
- The ratings given shall cover the operation of the multi-function integrated circuit over the specified range of operating temperatures. Where such ratings are temperature-dependent, these dependence should be indicated.

4.4.1 Electrical limiting values

Limiting values should be specified as follows: