



Designation: D7881 – 20

# Standard Test Method for Determination of 4-Carboxybenzaldehyde and *p*-Toluic Acid in Purified Terephthalic Acid by Capillary Electrophoresis with Reverse Voltage Mode<sup>1</sup>

This standard is issued under the fixed designation D7881; the number immediately following the designation indicates the year of original adoption or, in the case of revision, the year of last revision. A number in parentheses indicates the year of last reapproval. A superscript epsilon ( $\epsilon$ ) indicates an editorial change since the last revision or reapproval.

## 1. Scope\*

1.1 This test method<sup>2</sup> covers the determination of 4-carboxybenzaldehyde (4-CBA) and *p*-toluic acid (*p*-TOL) in purified terephthalic acid (PTA) by capillary electrophoresis (CE) with reverse voltage mode and UV detection. It is applicable for 4-CBA from 3 to 400 mg/kg and for *p*-TOL from 8 to 400 mg/kg, respectively.

1.2 In determining the conformance of the test results using this method to applicable specification, results shall be rounded off in accordance with the rounding-off method of Practice E29.

1.3 The values stated in SI units are to be regarded as standard. No other units of measurement are included in this standard.

1.4 This standard does not purport to address all of the safety concerns, if any, associated with its use. It is the responsibility of the user of this standard to establish appropriate safety, health, and environmental practices and determine the applicability of regulatory limitations prior to use.

1.5 This international standard was developed in accordance with internationally recognized principles on standardization established in the *Decision on Principles for the Development of International Standards, Guides and Recommendations issued by the World Trade Organization Technical Barriers to Trade (TBT) Committee*.

<sup>1</sup> This test method is under the jurisdiction of ASTM Committee D16 on Aromatic, Industrial, Specialty and Related Chemicals and is the direct responsibility of Subcommittee D16.02 on Oxygenated Aromatics.

Current edition approved Oct. 1, 2020. Published December 2020. Originally approved in 2013. Last previous edition approved in 2019 as D7881 – 19. DOI: 10.1520/D7881-20.

<sup>2</sup> This standard is based on SH/T 1687–2000 Purified terephthalic acid for industrial use—determination of 4-Carboxybenzaldehyde and *p*-Toluic Acid-High performance capillary electrophoresis (HPCE), copyright SINOPEC, 22 Chaoyangmen North Street, Chaoyang District, Beijing, China 100728. A copy of SH/T 1687–2000 may be obtained from China Petrochemical Press, [www.sinopecpress.com](http://www.sinopecpress.com).

## 2. Referenced Documents

### 2.1 ASTM Standards:<sup>3</sup>

D1193 Specification for Reagent Water

D6809 Guide for Quality Control and Quality Assurance Procedures for Aromatic Hydrocarbons and Related Materials

E29 Practice for Using Significant Digits in Test Data to Determine Conformance with Specifications

E691 Practice for Conducting an Interlaboratory Study to Determine the Precision of a Test Method

### 2.2 ISO Documents:<sup>4</sup>

EN ISO 8213 Chemical Products for Industrial Use—Sampling Techniques—Solid Chemical Products in the Form of Particles Varying from Powders to Coarse Lumps

### 2.3 Other Document:<sup>5</sup>

OSHA Regulations, 29 CFR paragraphs 1910.1000 and 1910.1200

## 3. Terminology

3.1 *Definitions of Terms Specific to Reverse Voltage Mode in this Standard:*

3.1.1 *capillary electrophoresis, n*—an electrophoretic technique in which a sample is introduced into a 50  $\mu\text{m}$  to 100  $\mu\text{m}$  i. d. fused-silica capillary filled with electrolyte solution and subjected to high voltage for separation.

3.1.1.1 *Discussion*—Reverse voltage, with the cathode on the injection side and the anode on the detection side, is applied across the capillary causing electrolyte and analytes to migrate towards the anode and through the capillary's UV detector

<sup>3</sup> For referenced ASTM standards, visit the ASTM website, [www.astm.org](http://www.astm.org), or contact ASTM Customer Service at [service@astm.org](mailto:service@astm.org). For *Annual Book of ASTM Standards* volume information, refer to the standard's Document Summary page on the ASTM website.

<sup>4</sup> Available from Available from American National Standards Institute (ANSI), 25 W. 43rd St., 4th Floor, New York, NY 10036, <http://www.ansi.org>.

<sup>5</sup> Available from U.S. Government Printing Office Superintendent of Documents, 732 N. Capitol St., NW, Mail Stop: SDE, Washington, DC 20401, <http://www.access.gpo.gov>.

\*A Summary of Changes section appears at the end of this standard

window. Analytes are separated based upon the differential rates of migration in the electrical field. Analyte detection and quantitation are based upon the principles of UV detection.

3.1.2 *electrolyte, n*—a combination of a buffer reagent, an ion-pair reagent and an electroosmotic-flow modifier placed inside the capillary, used as a carrier for the analytes, and for detection and quantitation.

3.1.3 *electroosmotic flow (EOF), n*—the directional velocity of electrolyte-solution flow within the capillary under an applied voltage; the velocity and direction of flow are determined by electrolyte chemistry, capillary-wall chemistry, and applied voltage.

3.1.4 *electroosmotic-flow modifier (OFM), n*—a cationic quaternary amine in the electrolyte that dynamically coats the negatively charged silica wall giving it a net positive charge.

3.1.4.1 *Discussion*—This modifier reverses the direction of the electrolyte’s natural electroosmotic flow and directs it towards the anode and detector. This modifier augments the analyte’s migration and enhances speed of analysis (see Fig. 1).

3.1.5 *electropherogram, n*—a graphical presentation of UV detector response versus time of analysis; the x-axis is migration time, which is used to identify the analyte qualitatively, and the y-axis is UV response, which can be converted to peak area or height for quantitation.

3.1.6 *electrophoretic mobility, n*—the specific velocity of a charged analyte in the electrolyte under specific electroosmotic-flow conditions.

3.1.6.1 *Discussion*—The mobility of an analyte is directly related to the analyte’s equivalent ionic conductance and applied voltage, and is the primary mechanism of separation.

3.1.7 *hydrodynamic sampling, n*—a sample introduction technique in which the injection side of the capillary with electrolyte is immersed into sample solution and then a positive pressure difference is applied.

3.1.7.1 *Discussion*—Nanolitres of sample are introduced into the capillary without analyte bias effects.

3.1.8 *electrokinetic sampling, n*—a sample introduction technique in which the injection side of the capillary with electrolyte and the electrode are inserted into the sample solution. A voltage is then applied, causing analytes to enter the capillary by electrophoretic migration and EOF.

3.1.8.1 *Discussion*—Nanolitres of sample are injected into the capillary with analyte bias effects. It has considerable benefit in terms of increased sensitivity when attempting to quantify trace levels of analytes.

3.1.9 *migration time, n*—the time required for a specific analyte to migrate through the capillary to the detector.

3.1.9.1 *Discussion*—The migration time in capillary electrophoresis is analogous to retention time in chromatography.

#### 4. Summary of Test Method

4.1 A PTA sample is dissolved in ammonium hydroxide solution. The 4-CBA, *p*-TOL and PTA dissociate and become homologous ions under basic conditions. A fixed amount of this solution is introduced into the capillary using hydrodynamic sampling or electrokinetic sampling. A voltage is applied to the capillary to separate the impurities, 4-CBA and *p*-TOL, from PTA. External standard calibration is used for quantification.

#### 5. Significance and Use

5.1 The presence of 4-CBA and *p*-TOL in PTA used for the production of polyester is undesirable because they can slow down the polymerization process; and 4-CBA is also imparting coloration to the polymer due to thermal instability.

5.2 Determining the amount of 4-CBA and *p*-TOL remaining from the manufacture of PTA is often required. This test

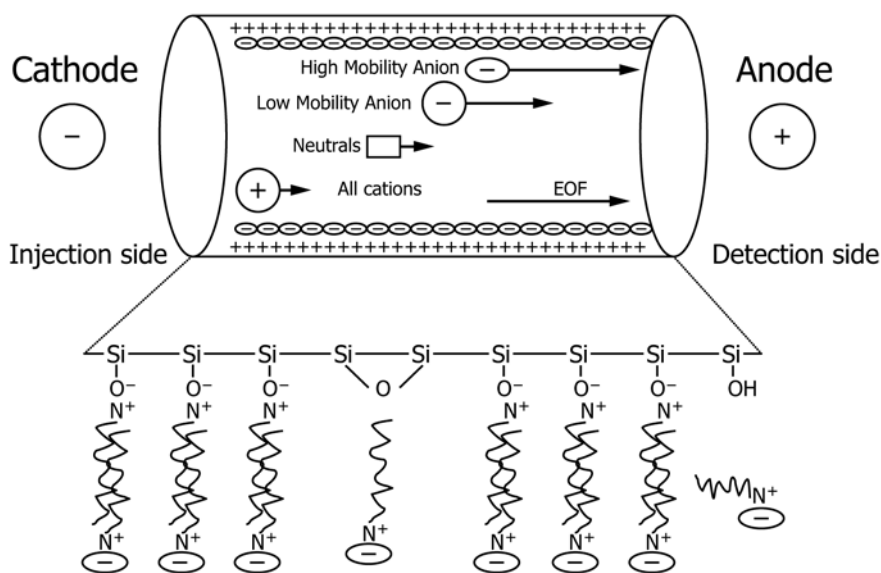

FIG. 1 Pictorial Diagram of Anion Mobility and Electroosmotic Flow Modifier

method is suitable for setting specifications and for use as an internal quality control where these products are produced or used.

5.3 This test method is intended as an alternative to the HPLC method for the determination of 4-CBA and *p*-TOL in PTA. The major benefits of CE are speed, simplicity, reduced reagent consumption, and operating costs.

## 6. Apparatus

6.1 *Capillary Electrophoresis System*—The system consists of the following components, as shown in Fig. 2, or equivalent:

6.1.1 *High Voltage Power Supply*, capable of generating voltage between 0 and 30 kV with the capability of working in a constant voltage mode.

6.1.2 *Covered Sample Carousel*, to prevent environmental contamination of the samples and electrolytes during a multi-sample batch analysis.

6.1.3 *Sample Introduction Mechanism*, capable of hydrodynamic sampling or electrokinetic sampling technique.

6.1.4 *Capillary Purge Mechanism*, to purge the capillary after every analysis with fresh electrolyte to eliminate any interference from the previous sample matrix, and to clean the capillary with sodium hydroxide solution and water.

6.1.5 *UV Detector*, having the capability of monitoring 200 nm, or equivalent.

6.1.6 *Fused Silica Capillary*, a 50 to 100  $\mu\text{m}$  (inner diameter) by 375  $\mu\text{m}$  (outer diameter) by 60 cm (length) having a polymer coating for flexibility, with an uncoated section to act as the cell window for UV detection.

6.1.7 *Constant Temperature Compartment*, to keep the samples, capillary, and electrolytes at constant temperature.

6.2 *Data System*, a computer system that can acquire data at 20 points/s minimum, express migration time in minutes to three decimal places.

6.3 *Sample Filter*, a disposable syringe filter made of cellulose acetate, with a pore size between 0.22 and 0.45  $\mu\text{m}$ ,

and is chemically inert to aqueous solutions, is recommended for the removal of particulate matter from the sample solution.

6.4 *pH Meter*, consisting of a glass-calomel double electrode, used to determine pH values of the solutions.

## 7. Reagents and Materials

7.1 *Purity of Reagents*—Unless otherwise indicated, it is intended that all reagents shall conform to the reagent grade specification for analytical reagents of the American Chemical Society, where such specifications are available.<sup>6</sup> Other grades may be used, provided it is first ascertained that the reagent is of sufficiently high purity to permit its use without lessening the performance or accuracy the determination. Reagent chemicals shall be used for all tests.

NOTE 1—Calibration and detection limits of this test method can be biased by the purity of the reagents.

7.2 *TetradecyltrimethylAmmonium Chloride*.

7.3 *Sodium 1-hexanesulfonate*.

7.4 *3-(Cyclohexylamino)-1-propanesulfonic Acid*.

7.5 *Sodium Phosphate Dibasic Dodecahydrate*.

7.6 *Sodium Hydroxide*.

7.7 *25 % (w/w) Ammonium Hydroxide Solution*.

7.8 *Purity of Water*—Unless otherwise indicated, references to water shall be understood to mean Type 1 reagent water conforming or exceeding Specification D1193. Freshly drawn water should be used for preparation of all stock and working standards, electrolytes, and solutions.

7.9 *PTA Standard for Calibrations*—A certified PTA calibration standard with known amounts of 4-CBA and *p*-TOL is required. If it is not commercially available, please refer to Annex A1 for determining the concentrations of 4-CBA and *p*-TOL in a PTA sample. The calibrated PTA sample can be served as a PTA calibration standard.

7.10 *OFM Concentrate Solution (0.05 mol/L tetradecyltrimethyl ammonium chloride)*—Dissolve approximately 0.75 g of tetradecyltrimethyl ammonium chloride (TTAC) in a 50-mL volumetric flask and dilute to 50 mL with water.

7.11 *Sodium Hydroxide Solution (0.5 mol/L sodium hydroxide)*—Dissolve approximately 20 g of sodium hydroxide in a 1 L plastic volumetric flask and dilute to 1 L with water.

7.12 *Ammonium Hydroxide Solution (2.5 % (m/m) ammonium hydroxide solution)*—Add approximately 50 mL 25 % (m/m) ammonium hydroxide solution in a 500-mL volumetric flask and dilute to 500 mL with water.

7.13 *Electrolyte Solution*, working in reverse voltage mode.

7.13.1 *Electrolyte solution A (50 mm sodium 1-hexanesulfonate, 10 mM disodium hydrogen phosphate and 1 mM OFM)*—Weigh approximately 0.50 g sodium

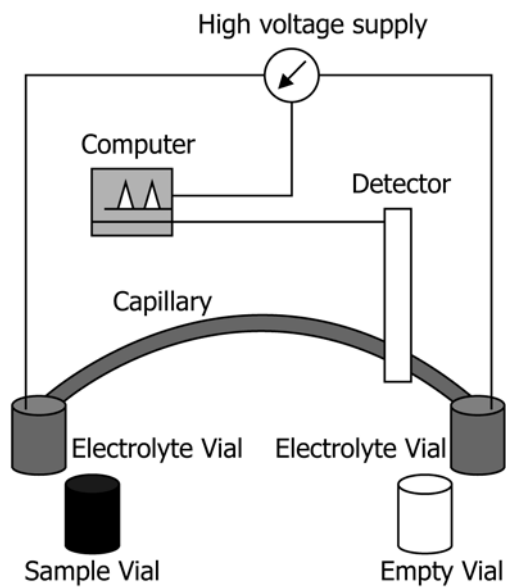

FIG. 2 Typical Instrumental Setup

<sup>6</sup> ACS Reagent Chemicals, Specifications and Procedures for Reagents and Standard-Grade Reference Materials, American Chemical Society, Washington, DC. For suggestions on the testing of reagents not listed by the American Chemical Society, see *Analar Standards for Laboratory Chemicals*, BDH Ltd., Poole, Dorset, U.K., and the *United States Pharmacopeia and National Formulary*, U.S. Pharmacopeial Convention, Inc. (USPC), Rockville, MD.

1-hexanesulfonate and 0.18 g sodium phosphate dibasic decahydrate in a 50-mL volumetric flask, add 1 mL OFM concentrate solution and dilute to 50 mL with water. Adjust the solution pH to 10.5 to 11.0 using 7.11 sodium hydroxide solution. Filter and degas the solution before use.

7.13.2 *Electrolyte Solution B (50 mM sodium 1-hexanesulfonate, 5 mM CAPS and 1 mM OFM)*—Weigh approximately 0.50 g sodium 1-hexanesulfonate and 0.06 g 3-(cyclohexylamino)-1-propanesulfonic acid (CAPS) in a 50-mL volumetric flask, add 1 mL OFM concentrate solution and dilute to 50 mL with water. Adjust the solution pH to 10.5 to 11.0 using 7.11 sodium hydroxide solution. Filter and degas the solution before use.

**8. Hazards**

8.1 Consult current federal regulations, supplier’s Safety Data Sheets, and local regulations for all materials used in this test method.

**9. Sampling**

9.1 Use only representative samples obtained as described in EN ISO 8213, unless otherwise specified.

**10. Preparation of Apparatus**

10.1 Set up the CE and data system according to the manufacturer’s instructions and adjust the instrument to the conditions described in Table 1 with the following procedures.

10.2 Program the CE system to maintain a constant temperature. Fill the electrolyte reservoirs with fresh electrolyte working solution and allow 10 min for thermal equilibration.

10.3 Condition a new capillary with 0.5 mol/L sodium hydroxide solution for 5 min followed by water for 5 min. Purge the capillary with electrolyte for 3 min.

10.4 Apply 15 kV voltage and test for current. If no current is observed, then there is a bubble or blockage, or both, in the capillary. Degas the electrolyte working solution and retry. If still no current, replace the capillary.

10.5 Set the UV detector to 200 nm detection, or equivalent. Zero the detector to 0.000 absorbance. UV offset is less than 0.1 AU.

10.6 Program the CE system with constant voltage of -(15-25) kV for reverse voltage mode.

10.7 Program the CE system for a hydrodynamic sampling or electrokinetic sampling. Different sampling times may be used provided that the samples and standards are analyzed identically.

10.8 Program the CE system for 1 min, 2 min, and 3 min, and purge with sodium hydroxide solution, water and the electrolyte in series between each analysis.

10.9 Program the data system for an acquisition rate of at least 20 points/s. Program the data system to identify analyte peaks based on migration time, and to quantitate analyte peak response using peak area.

**11. Procedure**

11.1 *Calibration:*

11.1.1 Accurately weigh, to the nearest 0.0001 g, about 0.5 g of PTA standard in a 25 mL beaker, add 7 mL of ammonium hydroxide solution (see 7.12), stir with heat or use an ultrasonic bath until PTA is completely dissolved. Then accurately transfer the resulting solution to a 25 mL volumetric flask, and dilute with water to the mark. When the operating conditions are steady, inject an amount of the calibration standard solution into the CE for analysis. Record electropherograms and the peak area values for 4-CBA and *p*-TOL, respectively, using the data system. Analyze the calibration standard a minimum of three times and calculate the average peak area.

NOTE 2—When reverse voltage mode is used for PTA sample with low concentration of 4-CBA, electrokinetic sampling mode is recommended.

11.2 *Analysis of Samples:*

11.2.1 Accurately weigh, to the nearest 0.001 g, about 0.5 g PTA sample, repeat the remaining steps in 11.1, and record peak area values of 4-CBA and *p*-TOL, respectively. Run the sample. After each analysis, rinse the capillary with sodium hydroxide for 1 min, with water for 2 min, and then with electrolyte for 3 min. Representative electropherogram of a PTA sample is shown in Fig. 3.

**12. Calculation**

12.1 Calculate the concentration of 4-CBA or *p*-TOL in mg/kg using the following equation:

$$X = \frac{m_s \cdot A \cdot C_s}{m \cdot A_s} \tag{1}$$

where:

- X = concentration of 4-CBA or *p*-TOL in the PTA sample, mg/kg,
- A = peak area of 4-CBA or *p*-TOL in the PTA sample,
- m = weight of the PTA sample, g,
- A<sub>s</sub> = average peak area of 4-CBA or *p*-TOL in the PTA standard,
- C<sub>s</sub> = concentration of 4-CBA or *p*-TOL in the PTA standard, mg/kg, and
- m<sub>s</sub> = weight of the PTA standard, g.

**TABLE 1 Recommended Operating Conditions**

Reverse Voltage Mode	
Electrolyte	50 mM sodium 1-hexanesulfonate, 10 mM disodium hydrogen phosphate and 1 mM OFM (pH = 10.5–11.0)
Applied voltage	-(15–25) kV
Injection technique	Electrokinetic sampling* –10 KV*90 s
Capillary purge program	NaOH solution 1 min; water 2 min; electrolyte 3 min
Capillary	Inner diameter (50–100) μm; length (40–70) cm
Detector	UV; 200 nm or equivalent
Capillary temperature	(20–30) °C

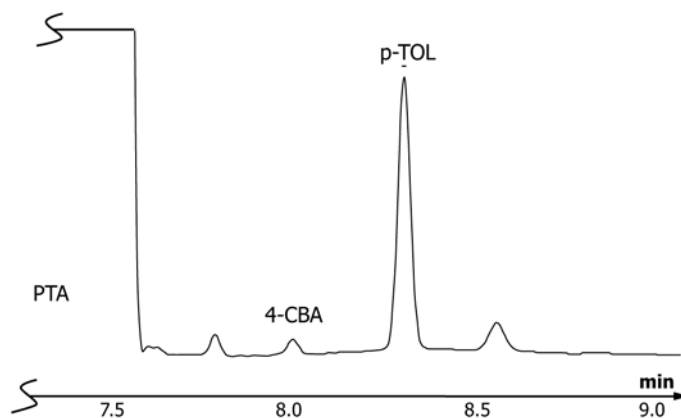

FIG. 3 Electropherogram of a PTA Sample in the Reverse Voltage Mode

### 13. Report

13.1 Report the concentration of 4-CBA and *p*-TOL in the PTA sample to the nearest 1 mg/kg.

13.2 Report the following information in the report:

13.2.1 The complete identification of the sample tested.

13.2.2 Any deviation from the procedure specified (for example, detailed description of column and operating conditions).

13.2.3 Results of the test.

13.2.4 Any abnormal situations observed during the test.

### 14. Precision and Bias<sup>7</sup>

14.1 An ILS was conducted which included five laboratories analyzing five samples two times in 2012. Practice E691 was followed for the design and analysis of the data. This ILS did not meet Practice E691 minimum requirements of six laboratories, four materials and two replicates. The detailed results are given in Research Report RR: D16-2000. The outliers were identified and removed using the *t* test.

14.2 *Repeatability (r)*—Results should not be suspect unless they differ by more than shown in Table 2. Results differing by less than *r* have a 95 % probability of being correct.

<sup>7</sup> Supporting data have been filed at ASTM International Headquarters and may be obtained by requesting Research Report RR:D16-2000. Contact ASTM Customer Service at service@astm.org.

14.3 *Reproducibility (R)*—Results submitted by two labs should not be considered suspect unless they differ by more than shown in Table 2. Results differing by less than *R* have a 95 % probability of being correct.

14.4 *Bias*—Since there is no accepted reference material suitable for determining the bias in this test method, bias has not been determined.

### 15. Quality Guidelines

15.1 Laboratories shall have a quality control system in place.

15.1.1 Confirm the performance of the test instrument or test method by analyzing a quality control sample following the guidelines for standard statistical quality control practices.

15.1.2 A quality control sample is a stable material isolated from the production process and representative of the sample being analyzed.

15.1.3 When QA/QC protocols are already established in the testing facility, these protocols are acceptable when they confirm the validity of test results.

15.1.4 When there are no QA/QC protocols established in the testing facility, use the guidelines described in Guide D6809 or similar statistical quality control practices.

#### 15.2 Interlaboratory Testing:

15.2.1 A program that includes multiple laboratories analyzing the same samples is strongly encouraged. This program

TABLE 2 Repeatability and Reproducibility

Analyte	Average (mg/kg) $\bar{x}$	Repeatability Limit <i>r</i>	Reproducibility Limit <i>R</i>
Reverse Voltage Mode 1			
a) 50 mM sodium 1-hexanesulfonate and 10 mM disodium hydrogen phosphate with 1 mM OFM (pH = 10.5-11.0)	4-CBA	10.99	1.00
	P-TOL	128.23	2.97
b) Electrokinetic sampling			
Reverse Voltage Mode 2			
a) 50 mM sodium 1-hexanesulfonate and 5 mM CAPS with 1 mM OFM (pH = 10.5-11.0)	4-CBA	11.51	2.77
	P-TOL	123.99	8.43
b) Electrokinetic sampling			