



Designation: D7882 – 20

# Standard Test Method for Determination of 4-Carboxybenzaldehyde and *p*-Toluic Acid in Purified Terephthalic Acid by Capillary Electrophoresis with Normal Voltage Mode<sup>1</sup>

This standard is issued under the fixed designation D7882; the number immediately following the designation indicates the year of original adoption or, in the case of revision, the year of last revision. A number in parentheses indicates the year of last reapproval. A superscript epsilon ( $\epsilon$ ) indicates an editorial change since the last revision or reapproval.

## 1. Scope\*

1.1 This test method covers the determination of 4-carboxybenzaldehyde (4-CBA) and *p*-toluic acid (*p*-TOL) in purified terephthalic acid (PTA) by capillary electrophoresis (CE) with normal voltage mode and UV detection. It is applicable for 4-CBA from 5 to 400 mg/kg and for *p*-TOL from 10 to 400 mg/kg, respectively.

1.2 In determining the conformance of the test results using this method to applicable specifications, results shall be rounded off in accordance with the rounding-off method of Practice E29.

1.3 The values stated in SI units are to be regarded as standard. No other units of measurement are included in this standard.

1.4 This standard does not purport to address all of the safety concerns, if any, associated with its use. It is the responsibility of the user of this standard to establish appropriate safety, health, and environmental practices and determine the applicability of regulatory limitations prior to use.

1.5 This international standard was developed in accordance with internationally recognized principles on standardization established in the Decision on Principles for the Development of International Standards, Guides and Recommendations issued by the World Trade Organization Technical Barriers to Trade (TBT) Committee.

## 2. Referenced Documents

2.1 ASTM Standards:<sup>2</sup>

D1193 Specification for Reagent Water

D6809 Guide for Quality Control and Quality Assurance

<sup>1</sup> This test method is under the jurisdiction of ASTM Committee D16 on Aromatic, Industrial, Specialty and Related Chemicals and is the direct responsibility of Subcommittee D16.02 on Oxygenated Aromatics.

Current edition approved Oct. 1, 2020. Published December 2020. Originally approved in 2013. Last previous edition approved in 2019 as D7882 – 19. DOI: 10.1520/D7882-20.

<sup>2</sup> For referenced ASTM standards, visit the ASTM website, www.astm.org, or contact ASTM Customer Service at service@astm.org. For Annual Book of ASTM Standards volume information, refer to the standard's Document Summary page on the ASTM website.

Procedures for Aromatic Hydrocarbons and Related Materials

E29 Practice for Using Significant Digits in Test Data to Determine Conformance with Specifications

E691 Practice for Conducting an Interlaboratory Study to Determine the Precision of a Test Method

2.2 ISO Document:<sup>3</sup>

EN ISO 8213 Chemical Products for Industrial Use—Sampling Techniques—Solid Chemical Products in the Form of Particles Varying from Powders to Coarse Lumps

2.3 Other Document:<sup>4</sup>

OSHA Regulations 29 CFR paragraphs 1910.1000 and 1910.1200

## 3. Terminology

3.1 Definitions of Terms Specific to Normal Voltage Mode in this Standard:

3.1.1 capillary electrophoresis, *n*—an electrophoretic technique in which a sample is introduced into a 50 to 100  $\mu\text{m}$  i.d. fused-silica capillary filled with electrolyte solution and subjected to high voltage for separation.

3.1.1.1 Discussion—Normal voltage, with the anode on the injection side and the cathode on the detection side, is applied across the capillary causing electrolyte and analytes to migrate towards the cathode and through the capillary's UV detector window. Analytes are separated based on the differential rates of migration in the electric field. Analyte detection and quantitation are based on the principles of UV detection.

3.1.2 electrolyte, *n*—a combination of a buffer reagent and an ion-pair reagent dissolved in an aqueous solution and placed inside the capillary, used as a carrier for the analytes.

3.1.3 electroosmotic flow (EOF), *n*—the directional velocity of electrolyte-solution flow within the capillary under an applied voltage; the velocity and direction of flow are determined by electrolyte chemistry, capillary-wall chemistry, and applied voltage (see Fig. 1).

<sup>3</sup> Available from American National Standards Institute (ANSI), 25 W. 43rd St., 4th Floor, New York, NY 10036, http://www.ansi.org.

<sup>4</sup> Available from U.S. Government Printing Office Superintendent of Documents, 732 N. Capitol St., NW, Mail Stop: SDE, Washington, DC 20401, http://www.access.gpo.gov.

\*A Summary of Changes section appears at the end of this standard

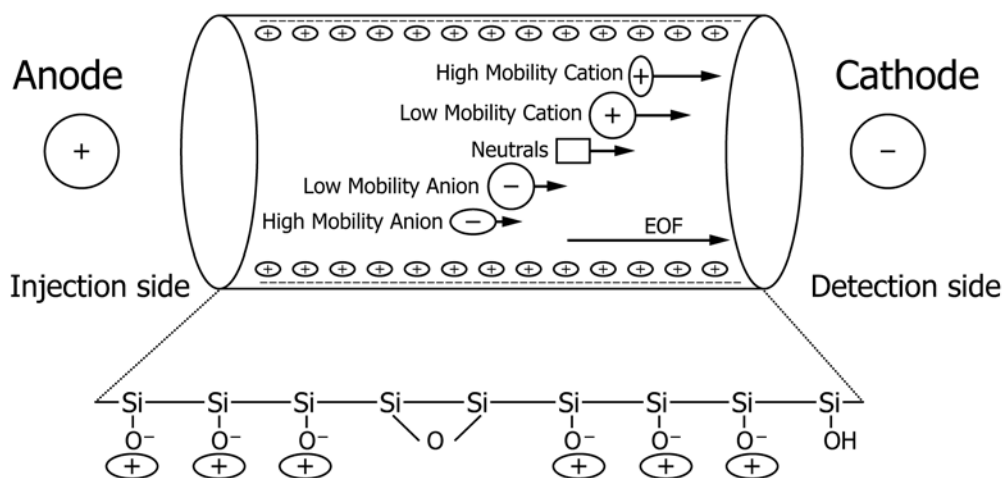

FIG. 1 Pictorial Diagram of Charged and Neutral Species Mobilities in CE

3.1.4 *electropherogram, n*—a graphical presentation of UV detector response versus time of analysis; the x-axis is migration time, which is used to identify the analyte qualitatively, and the y-axis is UV response, which can be converted to peak area or height for quantitation.

3.1.5 *electrophoretic mobility, n*—the specific velocity of a charged analyte in the electrolyte under specific electroosmotic-flow conditions.

3.1.5.1 *Discussion*—The mobility of an analyte is directly related to the analyte’s equivalent ionic conductance and applies voltage, and is the primary mechanism of separation.

3.1.6 *hydrodynamic sampling, n*—a sample introduction technique in which the injection side of the capillary with electrolyte is immersed into sample solution and then a positive pressure difference is applied.

3.1.6.1 *Discussion*—Nanolitres of sample are introduced into the capillary without analyte bias effects.

3.1.7 *migration time, n*—the time required for a specific analyte to migrate through the capillary to the detector.

3.1.7.1 *Discussion*—The migration time in capillary electrophoresis is analogous to retention time in chromatography.

**4. Summary of Test Method**

4.1 A PTA sample is dissolved in ammonium hydroxide solution. The 4-CBA, *p*-TOL and PTA dissociate and become homologous ions under basic conditions. A fixed amount of this solution is introduced into the capillary using hydrodynamic sampling. A voltage is applied to the capillary to separate the impurities, 4-CBA, and *p*-TOL, from PTA. External standard calibration is used for quantification.

**5. Significance and Use**

5.1 The presence of 4-CBA and *p*-TOL in PTA used for the production of polyester is undesirable because they can slow down the polymerization process; and 4-CBA is also imparting coloration to the polymer due to thermal instability.

5.2 Determining the amount of 4-CBA and *p*-TOL remaining from the manufacture of PTA is often required. This test

method is suitable for setting specifications and for use as an internal quality control where these products are produced or used.

5.3 This test method is intended as an alternative to the HPLC method for determination of 4-CBA and *p*-TOL in PTA. The major benefits of CE are speed, simplicity, reduced reagent consumption and operating costs.

**6. Apparatus**

6.1 *Capillary Electrophoresis System*—The system consists of the following components, as shown in Fig. 2 or equivalent:

6.1.1 *High Voltage Power Supply*, capable of generating voltage between 0 and 30 kV with the capability of working in a constant voltage mode.

6.1.2 *Covered Sample Carousel*, to prevent environmental contamination of the samples and electrolytes during a multi-sample batch analysis.

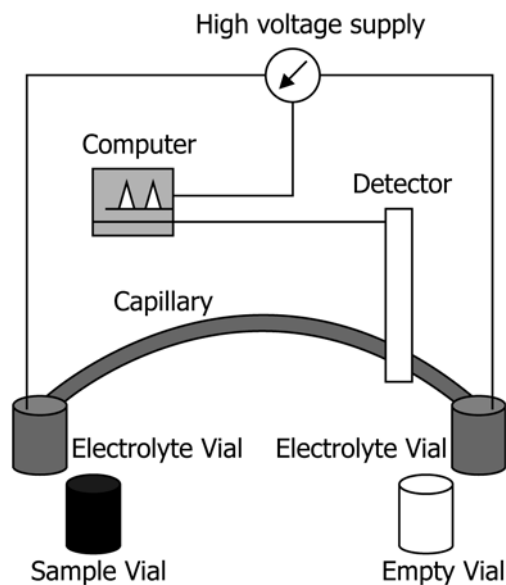

FIG. 2 Typical Instrumental Setup

6.1.3 *Sample Introduction Mechanism*, capable of hydrodynamic sampling technique.

6.1.4 *Capillary Purge Mechanism*, to purge the capillary after every analysis with fresh electrolyte to eliminate any interference from the previous sample matrix, and to clean the capillary with sodium hydroxide solution and water.

6.1.5 *UV Detector*, having the capability of monitoring 200 nm, or equivalent.

6.1.6 *Fused Silica Capillary*, a 50 to 100  $\mu\text{m}$  (inner diameter) by 375  $\mu\text{m}$  (outer diameter) by 60 cm (length) having a polymer coating for flexibility, with an uncoated section to act as the cell window for UV detection.

6.1.7 *Constant Temperature Compartment*, to keep the samples, capillary, and electrolytes at constant temperature.

6.2 *Data System*, a computer system that can acquire data at 20 points/s minimum, express migration time in minutes to three decimal places.

6.3 *Sample Filter*, a disposable syringe filter made of cellulose acetate, with a pore size between 0.22 and 0.45  $\mu\text{m}$ , and is chemically inert to aqueous solutions, is recommended for the removal of particulate matter from the sample solution.

6.4 *pH Meter*, consisting of a glass-calomel double electrode, used to determine pH values of the solutions.

## 7. Reagents and Materials

7.1 *Purity of Reagents*—Unless otherwise indicated, it is intended that all reagents shall conform to the reagent grade specification for analytical reagents of the American Chemical Society, where such specifications are available.<sup>5</sup> Other grades may be used, provided it is first ascertained that the reagent is of sufficiently high purity to permit its use without lessening the performance or accuracy of the determination. Reagent chemicals shall be used for all tests.

NOTE 1—Calibration and detection limits of this test method can be biased by the purity of the reagents.

7.2 *Sodium 1-heptanesulfonate*.

7.3 *Sodium Phosphate Tribasic Dodecahydrate*.

7.4 *Sodium Hydroxide*.

7.5 *25 % (w/w) Ammonium Hydroxide Solution*.

7.6 *Purity of Water*—Unless otherwise indicated, references to water shall be understood to mean Type 1 reagent water conforming to or exceeding Specification D1193. Freshly drawn water should be used for preparation of all stock and working standards, electrolytes, and solutions.

7.7 *PTA Standard for Calibration*—A certified PTA calibration standard with known amounts of 4-CBA and *p*-TOL is required. If it is not commercially available, please refer to Annex A1 for determining the concentrations of 4-CBA and

*p*-TOL in a PTA sample. The calibrated PTA sample can be served as a PTA calibration standard.

7.8 *Sodium Hydroxide Solution (0.5 mol/L sodium hydroxide)*—Dissolve approximately 20 g of sodium hydroxide in a 1 L plastic volumetric flask and dilute to 1 L with water.

7.9 *Ammonium Hydroxide Solution (2.5 % (m/m) ammonium hydroxide solution)*—Add approximately 50 mL 25 % (m/m) ammonium hydroxide solution in a 500-mL volumetric flask and dilute to 500 mL with water.

7.10 *Electrolyte Solution, Working in Normal Voltage Mode (50 mM sodium 1-heptanesulfonate and 10 mM trisodium phosphate)*—Dissolve approximately 0.50 g sodium 1-heptanesulfonate and 0.19 g sodium phosphate tribasic dodecahydrate in a 50-mL volumetric flask and dilute to 50 mL with water. Filter and degas the solution before use.

## 8. Hazards

8.1 Consult current federal regulations, supplier's Safety Data Sheets, and local regulations for all materials used in this test method.

## 9. Sampling

9.1 Use only representative samples obtained as described in EN ISO 8213, unless otherwise specified.

## 10. Preparation of Apparatus

10.1 Set up the CE and data system according to the manufacturer's instructions and adjust the instrument to the conditions described in Table 1 with the following procedures.

10.2 Program the CE system to maintain a constant temperature. Fill the electrolyte reservoirs with fresh electrolyte working solution, and allow 10 min for thermal equilibration.

10.3 Condition a new capillary with 0.5 mol/L sodium hydroxide solution for 5 min followed by water for 5 min. Purge the capillary with electrolyte for 3 min.

10.4 Apply 15 kV voltage and test for current. If no current is observed, then there is a bubble, or blockage, or both, in the capillary. Degas the electrolyte working solution and retry. If still no current, replace the capillary.

10.5 Set the UV detector to 200 nm detection, or equivalent. Zero the detector to 0.000 absorbance. UV offset is less than 0.1 AU.

10.6 Program the CE system with the constant voltage of +(15-25) kV for normal voltage mode.

TABLE 1 Recommended Operating Conditions

	Normal Voltage Mode
Electrolyte	50 mM sodium 1-heptanesulfonate and 10 mM trisodium phosphate
Applied voltage	+(15-25) kV
Injection technique	Hydrodynamic sampling 3.3 kPa*15 s
Capillary purge program	water 10 min; Electrolyte 6 min
Capillary	Inner diameter (50-100) $\mu\text{m}$ ; length (40-70) cm
Detector	UV; 200 nm or equivalent
Capillary temperature	(20-30) $^{\circ}\text{C}$

<sup>5</sup> ACS Reagent Chemicals, Specifications and Procedures for Reagents and Standard-Grade Reference Materials, American Chemical Society, Washington, DC. For suggestions on the testing of reagents not listed by the American Chemical Society, see *Analar Standards for Laboratory Chemicals*, BDH Ltd., Poole, Dorset, U.K., and the *United States Pharmacopeia and National Formulary*, U.S. Pharmacopeial Convention, Inc. (USPC), Rockville, MD.

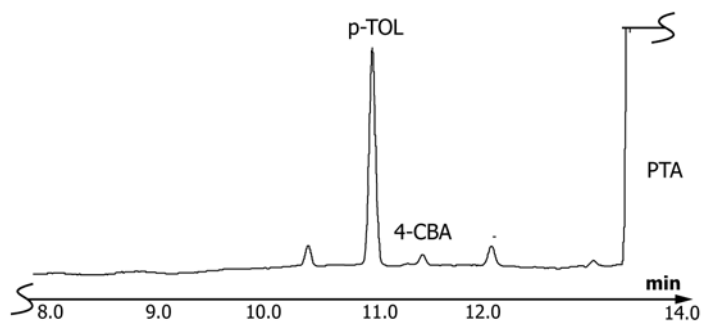

FIG. 3 Electropherogram of a PTA Sample in the Normal Voltage Mode

10.7 Program the CE system for a hydrodynamic sampling. Different sampling times may be used provided that the samples and standards are analyzed identically.

10.8 Program the CE system for 10 min and 6 min, purge with water and the electrolyte in series between each analysis.

10.9 Program the data system for an acquisition rate of at least 20 points/s. Program the data system to identify analyte peaks based on migration time, and to quantitate analyte peak response using peak area.

## 11. Procedure

### 11.1 Calibration:

11.1.1 Accurately weigh, to the nearest 0.0001 g, about 0.5 g of PTA standard in a 25 mL beaker, add 7 mL of ammonium hydroxide solution (see 7.9), stir with heat or use an ultrasonic bath until PTA is completely dissolved. Then accurately transfer the resulting solution to a 25 mL volumetric flask and dilute with water to the mark. When the operating conditions are steady, inject an amount of the calibration standard solution into the CE for analysis. Record electropherograms and the peak area values for 4-CBA and *p*-TOL, respectively, using the data system. Analyze the calibration standard a minimum of three times and calculate the average peak area.

### 11.2 Analysis of Samples:

11.2.1 Accurately weigh, to the nearest 0.0001 g, about 0.5 g PTA sample, repeat the remaining steps in 11.1, and record peak area values of 4-CBA and *p*-TOL, respectively. Run the sample. After each analysis, rinse the capillary with water for 10 min, and then with electrolyte for 6 min. Representative electropherogram of a PTA sample is shown in Fig. 3.

## 12. Calculation

12.1 Calculate the concentration of 4-CBA or *p*-TOL in mg/kg using the following equation:

$$X = \frac{m_s \cdot A \cdot C_s}{m \cdot A_s} \quad (1)$$

where:

- $X$  = concentration of 4-CBA or *p*-TOL in the PTA sample, mg/kg,
- $A$  = peak area of 4-CBA or *p*-TOL in the PTA sample,
- $m$  = weight of the PTA sample, g,
- $A_s$  = average peak area of 4-CBA or *p*-TOL in the PTA standard,

- $C_s$  = concentration of 4-CBA or *p*-TOL in the PTA standard, mg/kg,
- $m_s$  = weight of the PTA standard, g.

## 13. Report

13.1 Report the concentration of 4-CBA and *p*-TOL in the PTA sample to the nearest 1 mg/kg.

13.2 Report the following information in the report:

13.2.1 The complete identification of the sample tested.

13.2.2 Any deviation from the procedure specified (for example, detailed description of column and operating conditions).

13.2.3 Results of the test.

13.2.4 Any abnormal situations observed during the test.

## 14. Precision and Bias<sup>6</sup>

14.1 An ILS was conducted which included four laboratories analyzing five samples two times in 2012. Practice E691 was followed for the design and analysis of the data. This ILS did not meet Practice E691 minimum requirements of six laboratories, four materials and two replicates. The detailed results are given in Research Report RR:D16-2001. The outliers were identified and removed using the t test.

14.2 *Repeatability (r)*—Results should not be suspect unless they differ by more than shown in Table 2. Results differing by less than  $r$  have a 95 % probability of being correct.

14.3 *Reproducibility (R)*—Results submitted by two labs should not be considered suspect unless they differ by more than shown in Table 2. Results differing by less than  $R$  have a 95 % probability of being correct.

<sup>6</sup> Supporting data have been filed at ASTM International Headquarters and may be obtained by requesting Research Report RR:D16-2001. Contact ASTM Customer Service at service@astm.org.

TABLE 2 Repeatability and Reproducibility

Analyte	Average (mg/kg) $\bar{x}$	Repeatability Limit $r$	Reproducibility Limit $R$
4-CBA	11.01	1.28	4.11
P-TOL	126.65	5.25	12.59