



Designation: **F1336—15 F1336 – 20**

Standard Specification for Poly(Vinyl Chloride) (PVC) Gasketed Sewer Fittings¹

This standard is issued under the fixed designation F1336; the number immediately following the designation indicates the year of original adoption or, in the case of revision, the year of last revision. A number in parentheses indicates the year of last reapproval. A superscript epsilon (ϵ) indicates an editorial change since the last revision or reapproval.

1. Scope*

1.1 This specification covers requirements and test methods for fabricated or molded poly(vinyl chloride) (PVC) gasketed sewer fittings to be used with piping manufactured to Specifications **D3034**, **F679**, **F891** or **F1760**. Fabricated fittings may be manufactured from pipe, or from a combination of pipe and injection molded parts, or from injection molded parts. Gasketed sewer fitting configurations may include one or more spigot outlets.

1.2 The requirements of this specification are to provide fabricated or molded PVC gasketed fittings suitable for non-pressure drainage of sewage and surface water, as well as applications involving subsurface drainage.

NOTE 1—Industrial waste lines should be installed only with the specific approval of the governing code authority when using chemicals not commonly found in drains and sewers or temperatures in excess of 140°F (60°C), 140°F (60°C), or both.

1.3 Fittings produced to this specification are intended to be installed with pipe, in accordance with Practice **D2321**.

1.4 The values stated in inch-pound units are to be regarded as standard. The values given in parentheses are mathematical conversions to SI units that are provided for information only and are not considered standard.

1.5 The following precautionary caveat pertains to the test method portion only, Section **10**, of this specification. *This standard does not purport to address all of the safety concerns, if any, associated with its use. It is the responsibility of the user of this standard to establish appropriate safety—safety, health, and healthenvironmental practices and determine the applicability of regulatory limitations prior to use.*

1.6 *This international standard was developed in accordance with internationally recognized principles on standardization established in the Decision on Principles for the Development of International Standards, Guides and Recommendations issued by the World Trade Organization Technical Barriers to Trade (TBT) Committee.*

2. Referenced Documents

2.1 ASTM Standards:²

D618 Practice for Conditioning Plastics for Testing

D1600 Terminology for Abbreviated Terms Relating to Plastics

D1784 Classification System and Basis for Specification for Rigid Poly(Vinyl Chloride) (PVC) Compounds and Chlorinated Poly(Vinyl Chloride) (CPVC) Compounds

D2122 Test Method for Determining Dimensions of Thermoplastic Pipe and Fittings

¹ This specification is under the jurisdiction of ASTM Committee **F17** on Plastic Piping Systems and is the direct responsibility of Subcommittee **F17.62** on Sewer. Current edition approved Nov. 1, 2015; Nov. 1, 2020. Published December 2015; December 2020. Originally approved in 1991. Last previous edition approved in 2007; 2015 as **F1336—07**; **F1336 – 15**. DOI: [10.1520/F1336-15.10.1520/F1336-20](https://doi.org/10.1520/F1336-15.10.1520/F1336-20).

² For referenced ASTM standards, visit the ASTM website, www.astm.org, or contact ASTM Customer Service at service@astm.org. For *Annual Book of ASTM Standards* volume information, refer to the standard's Document Summary page on the ASTM website.

*A Summary of Changes section appears at the end of this standard

D2321 Practice for Underground Installation of Thermoplastic Pipe for Sewers and Other Gravity-Flow Applications
D2444 Practice for Determination of the Impact Resistance of Thermoplastic Pipe and Fittings by Means of a Tup (Falling Weight)
D2564 Specification for Solvent Cements for Poly(Vinyl Chloride) (PVC) Plastic Piping Systems
D2749 Symbols for Dimensions of Plastic Pipe Fittings
D3034 Specification for Type PSM Poly(Vinyl Chloride) (PVC) Sewer Pipe and Fittings
D3212 Specification for Joints for Drain and Sewer Plastic Pipes Using Flexible Elastomeric Seals
F412 Terminology Relating to Plastic Piping Systems
F477 Specification for Elastomeric Seals (Gaskets) for Joining Plastic Pipe
F610/F610M Practice for Evaluating the Quality of Molded Poly(Vinyl Chloride) (PVC) Plastic Pipe Fittings by the Heat Reversion Technique
F656 Specification for Primers for Use in Solvent Cement Joints of Poly(Vinyl Chloride) (PVC) Plastic Pipe and Fittings
F679 Specification for Poly(Vinyl Chloride) (PVC) Large-Diameter Plastic Gravity Sewer Pipe and Fittings
F891 Specification for Coextruded Poly(Vinyl Chloride) (PVC) Plastic Pipe With a Cellular Core
F913 Specification for Thermoplastic Elastomeric Seals (Gaskets) for Joining Plastic Pipe
F1760 Specification for Coextruded Poly(Vinyl Chloride) (PVC) Non-Pressure Plastic Pipe Having Reprocessed-Recycled Content

2.2 *Federal Standard:*

Fed. Std. No. 123 Marking for Shipment (Civil Agencies)³

2.3 *Military Standard:*

MIL-STD-129 Marking for Shipment and Storage³

3. Terminology

3.1 Definitions are in accordance with Terminology F412 unless otherwise specified.

3.1.1 Abbreviations are in accordance with Terminology D1600, unless otherwise indicated. The abbreviation for poly(vinyl chloride) plastic is PVC. The abbreviation for plastic sewer main is PSM.

4. Materials and Manufacture

4.1 *Basic Materials*—The pipe components for fabricated fittings shall be made from PVC compounds meeting the cell classifications indicated under the material section of the pipe standards referenced in 1.1. Molded components or fittings shall be made from virgin or rework PVC compound having a cell classification of 12454 or 13343 as prescribed in Specification D1784. Virgin or rework compounds that have different cell classifications because one or more properties exceed the minimum requirements of those specified compounds are also acceptable.

4.2 *Rework Material*—Clean rework material generated from the manufacturer's own pipe, molded components, or fittings production may be used by the same manufacturer providing the rework material meets the requirements of 4.1 and that the pipe, molded components, or fittings produced meet all the requirements of this specification.

5. Miscellaneous Requirements

5.1 *Gasketed Joining System:*

5.1.1 The assembled joint shall display no leakage when tested in accordance with the requirements of Specification D3212.

5.1.2 The joint assembly shall be in accordance with the fitting manufacturer's recommendations. The end of the pipe or fitting spigot shall not damage or dislodge the gasket during insertion. Lubricant is required on the spigot and sometimes additionally on the gasket. All surfaces of the joint that make contact with the gasket shall be smooth and free of imperfections, ridges, fractures, or cracks that could adversely affect the seal.

5.1.3 The dimensions of the elastomeric gasket seal joints shall accommodate pipes and fitting spigots having the average outside diameters and tolerances detailed in Table 1.

³ DLA Document Services Building 4/D 700 Robbins Avenue Philadelphia, PA 19111-5094 <http://quicksearch.dla.mil/>

TABLE 1 Dimensions and Tolerances

Nominal Size in. (mm)	Outside Diameter				Wall Thickness ^A						Wall Thickness in accordance with Specification F679			
	Average		Tolerance		SDR35		SDR26		DR23.5		PS46		PS115	
	in.	mm	in. ±	mm ±	in.	mm	in.	mm	in.	mm	in.	mm	in.	mm
4 (100)	4.215	107.06	±0.009	±0.23	0.120	3.05	0.162	4.11	0.178	4.52
5 (125)	5.640	143.26	±0.010	±0.25	0.161	4.09	0.217	5.51
6 (150)	6.275	159.39	±0.011	±0.28	0.180	4.57	0.241	6.13	0.265	6.73
8 (200)	8.400	213.36	±0.012	±0.30	0.240	6.10	0.323	8.20
10 (250)	10.500	266.70	±0.015	±0.38	0.300	7.62	0.404	10.26
12 (300)	12.500	317.50	±0.018	±0.46	0.360	9.14	0.481	12.22
15 (375)	15.300	388.62	±0.023	±0.58	0.437	11.10	0.588	14.94
18 (450)	18.700	474.98	±0.028	±0.71	0.536	13.61	0.719	18.26	0.499	12.70	0.671	17.00
21 (525)	22.047	559.99	±0.033	±0.84	0.632	16.05	0.848	21.54	0.588	14.90	0.791	20.10
24 (600)	24.803	630.00	±0.037	±0.94	0.711	18.06	0.954	24.23	0.661	15.50	0.889	22.60
27 (675)	27.953	710.01	±0.042	±1.07	0.801	20.35	1.075	27.31	0.745	18.90	1.002	25.50
30 (750)	32.000	813.00	±0.040	±1.02	0.914	23.21	1.231	31.26	0.853	21.70	1.148	29.10
36 (900)	38.300	973.00	±0.050	±1.27	1.094	27.79	1.473	37.42	1.021	25.90	1.373	34.10
42 (1050)	44.500	1130.00	±0.060	±1.52	1.271	32.28	1.740	43.47	1.187	30.10	1.596	40.50
48 (1200)	50.800	1290.00	±0.075	±1.90	1.451	36.86	1.954	49.63	1.355	34.40	1.822	46.30
54 (1350)	57.560	1462.00	±0.085	±2.15	1.535	39.00	2.064	52.40
60 (1500)	61.610	1565.00	±0.090	±2.30	1.643	41.70	2.210	56.10

^A10 % variation resulting from a core shift or other processes is allowable; however, the average of the two opposite wall thickness shall equal or exceed the value shown in the table.

5.2 Elastomeric Seal Components :

5.2.1 *Bells*—The dimensions shall be in accordance with the manufacturer’s standard design dimensions and tolerances.

5.2.2 *Gaskets*—The elastomeric seal (gasket) shall comply with the requirements of Specifications **F477** or **F913** at the time the fittings are manufactured.

5.3 *Lubricant*—The lubricant used for field assembly shall be the type recommended by the manufacturer of the gasketed joint.

5.4 *Fabrication Joint Material*—The fabrication joint material or reinforcing overlays shall be of that type, strength, and properties suitable for the intended fabrication. It is the decision of the manufacturer as to what material will be used. The PVC primer shall meet the requirements of Specification **F656**. The PVC solvent cement shall meet the requirements of Specification **D2564**.

5.5 *Over-Wrapped Fittings*—Fabricated fittings that have a reinforcing overlay of fiberglass and thermosetting resin shall meet all of the requirements of this specification except for **4.1** and **4.2**.

5.6 *Pipe Performance*—When pipe is used to fabricate a fitting, the pipe shall meet the requirements of the relevant ASTM standards.

5.7 *Waterway*—Fabricated fittings shall be constructed so that pipe ends do not project into the waterway of the fitting body.

6. Dimensions and Permissible Variations

6.1 *Diameter*—The average outside diameter of molded fitting spigots or of spigot pipe components for fabricated fittings shall meet the requirements given in **Table 1** when measured in accordance with **10.1.1**.

6.2 Wall Thickness:

6.2.1 *Fabricated Fittings*—Pipe wall thickness shall meet the requirements of the applicable specifications mentioned in the scope of this specification when measured in accordance with Test Method **D2122** and **10.1.2**, and shall have a minimum pipe stiffness of 46 psi. In the case of fittings fabricated from pipe sections, the thickness of the wall in the bell and the branch area shall be considered satisfactory if it was formed from pipe meeting those requirements.

6.2.2 *Molded Fittings or Components*—The wall thickness of the waterway and socket or bell of molded fittings or components shall be no less than the respective minimum thickness indicated in Table 1. For reducing fittings or those with smaller inlets, the minimum wall thickness of each inlet shall be no less than the minimum wall thickness indicated in Table 1 for that nominal pipe size. The thickness shall be determined in accordance with Test Method D2122 and 10.1.2

NOTE 2—Refer to Fig. 1, Fig. 2, and Appendix X1 for geometric configurations as illustrations of some of the fittings being produced. Consult the individual manufacturer for laying lengths.

6.3 *Socket Length*—The minimum distance from the center of the gasket to the bottom of the socket and the maximum distance from the center of the gasket to the outermost edge of fitting socket (see Fig. 3) shall comply with the dimensions given in Table 2 when measured in accordance with Test Method D2122 and 10.1.3.

6.4 *Spigot Length*—The minimum distance from the spigot end to the area where spigot diameter changes due to a socket, branch, or change in angle shall comply with the dimensions given in Table 2 when measured in accordance with 10.1.4.

7. Mechanical Properties

7.1 *Impact Strength*—The impact strength of tees, wyes, couplings, bends, increasers/reducers, and saddles shall be no less than the values given in Table 3, when tested in accordance with 10.2.

NOTE 3—This test is intended only for use as a quality control test; not for use as a simulated service test.

7.2 *Pipe Stop Load Support*—Tee, tee-wye, or saddle tee shall support the load indicated in Table 4, when tested in accordance with 10.3.

NOTE 4—This test is intended only for use as a quality control test; not for use as a simulated service test.

7.3 *Internal Stress*—Molded components or fittings shall be tested in accordance with 10.4.

7.4 *Branch Bending*—The wye or tee branch of a fabricated fitting shall be subject to a load in accordance with 10.5.

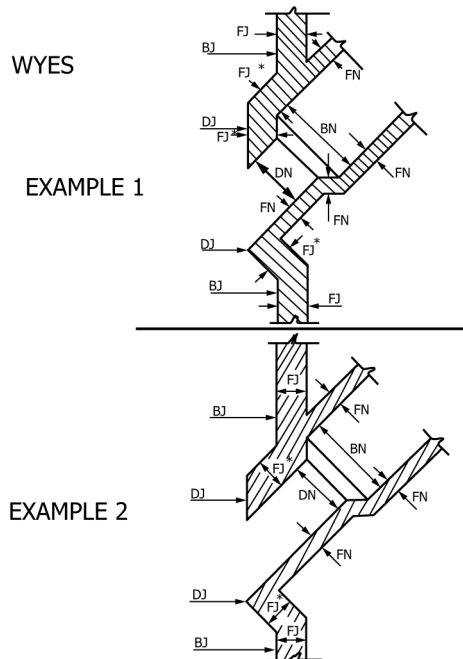
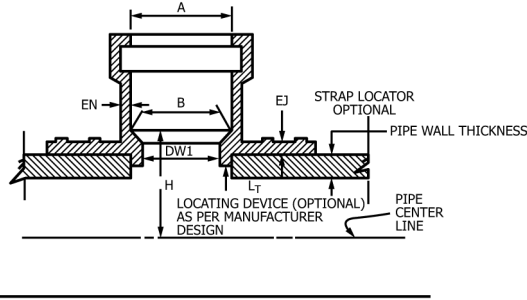
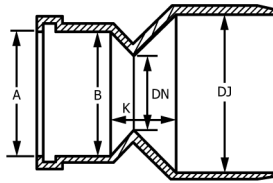

FIG. 1 Product Design Examples

SADDLE TEE



REDUCER COUPLING



TEE

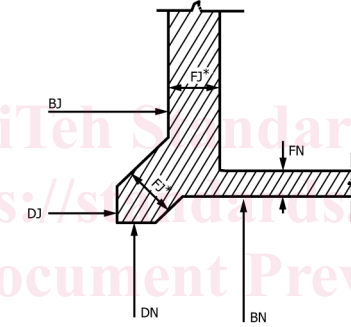

SADDLE WYE

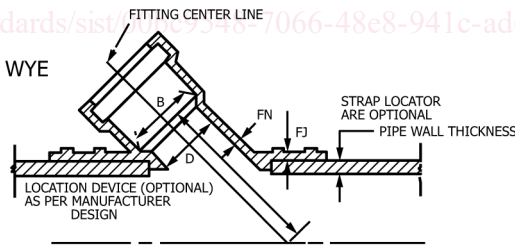

NOTE 1—The asterisk (*) in the examples indicates that the region beyond the intersection of the branch and the main body is considered a transition area and may vary based on individual manufacturers design.

NOTE 2— Dimensions are identified according to Symbols D2749. Consult the manufacturer for their actual values.

FIG. 2 Product Design Examples (continued)

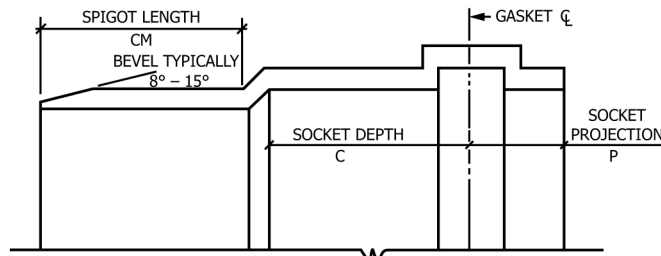

FIG. 3 Socket/Spigot Descriptions

TABLE 2 Socket and Spigot Dimensions^A

Nominal Size, in. (mm)	Socket		Spigot
	Depth, "C" min, in. (mm)	Projection, "P" max, in. (mm)	Length, "cm" min, in. (mm)
4 (100)	1.50 (38.1)	1.75 (44.5)	2.25 (57.1)
5 (125)	1.97 (50)	1.75 (44.5)	3.00 (76.2)
6 (150)	2.15 (54.6)	2.00 (50.8)	3.50 (88.9)
8 (200)	2.50 (63.5)	2.50 (63.5)	4.10 (104.1)
10 (250)	2.92 (74.2)	3.00 (76.2)	5.00 (127)
12 (300)	3.10 (78.7)	3.50 (88.9)	6.00 (152.4)
15 (375)	3.20 (81.3)	4.00 (101.6)	7.50 (190.5)
18 (450)	4.10 (104.1)	4.50 (114.3)	8.60 (218.4)
21 (525)	4.61 (117.1)	5.00 (127)	9.60 (244)
24 (600)	5.12 (130)	5.50 (139.7)	10.62 (269.7)
27 (675)	5.63 (143)	6.00 (152.4)	11.60 (294.6)
30 (750)	10.00 (254)	5.75 (146.1)	14.49 (368.0)
36 (900)	11.00 (279.4)	5.75 (146.1)	15.47 (392.9)
42 (1050)	12.00 (304.8)	5.75 (146.1)	16.50 (419.1)
48 (1200)	12.00 (304.8)	6.50 (165.1)	17.48 (444.0)

^ARefer to Fig. 3 as to location.

TABLE 3 Impact Strength

Fitting Size, in. (mm)	Impact Strength	
	ft-lbf	J
4 (100)	50	68
5 (125)	60	81
6 (150)	75	101
8 (200)	75	101
10 (250)	90	122
12 (300)	90	122
15 (375)	120	162
18 (450)	120	162
21 (525)	150	203
24 (600)	150	203
27 (675)	180	243
30 (750)	180	243
36 (900)	210	285
42 (1050)	240	325
48 (1200)	240	325

TABLE 4 Pipe Stop Support

Branch Nominal Diameter, in. (mm)	Load	
	lb	kg
4 (100)	1320	599
5 (125)	1770	803
6 (150)	1970	894
8 (200)	2630	1193
10 (250)	3290	1492
12 (300)	3920	1778
15 (375)	4800	2177
18 (450)	5000	2268
21 (525)	5000	2268
24 (600)	5000	2268
27 (675)	5000	2268
30 (750)	5000	2268
36 (900)	5000	2268
42 (1050)	5000	2268
48 (1200)	5000	2268

NOTE 5—This is intended only for use as a quality control test; not for use as a simulated service test.

8. Workmanship, Finish, and Appearance

8.1 The fittings shall be homogeneous throughout and free from visible cracks, holes, foreign inclusions, or other injurious defects. The fittings shall be as uniform as commercially practical in color, opacity, density, and other physical properties.

9. Sampling and Conditioning

9.1 ~~Sampling~~—~~Sampling~~—The selection of fitting samples shall be as agreed upon between the purchaser and the seller. In case of no prior agreement, samples selected by the testing laboratory shall be deemed adequate.

9.2 Conditioning:

9.2.1 ~~Referee Testing~~—~~The Referee Testing~~—The specimen shall be conditioned in accordance with Procedure A of Practice **D618** at ~~73.473 ± 3.6°F~~ $23 \pm 2^\circ\text{C}$ and $50 \pm 5\%$ relative humidity for not less than 40 h prior to test. Tests shall be conducted at the same conditions of temperature and humidity, unless otherwise specified.

9.2.2 ~~Quality Control Tests~~—~~For Quality Control Tests~~—For quality control tests, the specimens shall be conditioned for a minimum of 4 h in air or 1 h in water at ~~73.473 ± 3.6°F~~ $23 \pm 2^\circ\text{C}$. The specimen shall be tested at ~~73.473 ± 3.6°F~~ $23 \pm 2^\circ\text{C}$ without regard to relative humidity.

10. Test Methods

10.1 ~~Dimensions and Tolerances~~: *Dimensions and Tolerances:*

10.1.1 ~~Diameter~~—~~The Diameter~~—The average outside diameter of a pipe or spigot component shall be measured in accordance with Test Method **D2122**. A measurement device accurate to 0.001 in. (0.02 mm) shall be used.

10.1.2 ~~Wall Thickness~~—~~Wall Thickness~~—Wall thickness shall be measured in accordance with Test Method **D2122**. A measurement device accurate to 0.001 in. (0.02 mm) shall be used.

10.1.3 ~~Socket Length~~—~~Socket Length~~—Socket length shall be measured in accordance with Test Method **D2122**. A steel rule, with at least 0.031-in. or 1-mm graduations shall be used. Refer to **Fig. 3** for measuring locations.

10.1.4 ~~Spigot Length~~—~~Spigot Length~~—Spigot lengths shall be measured using a steel rule with at least 0.031-in. or 1-mm graduations. Refer to **Fig. 3** for measuring locations.

10.2 ~~Impact Strength~~—~~Determine Impact Strength~~—Determine in accordance with Test Method **D2444**, using a 20-lb (9.1-kg) Tup A for sizes 18 in. and smaller; 30-lb (13.6-kg) Tup A for sizes above 18 in. Flat Plate Holder B shall be used. Test six specimens at the impact levels shown in **Table 3**. Support with shim(s) one of the largest hub(s) under the bell and hit mid point between gasket groove and bottom of bell. Test conditions shall be in accordance with **9.2.1** or **9.2.2**. Five of the six specimens shall pass. If two or more fail, test another six specimens. Nine passes out of twelve tested shall be acceptable.

10.3 ~~Pipe Stop Load Support~~—~~A Pipe Stop Load Support~~—A sample of a tee, tee-wye, or saddle tee shall be placed on Flat Plate Holder B, with the branch socket at 90° to the support surface. Reference **Fig. 4** and **Fig. 5**, Alternates 1 or 2, for location of test fixtures and positioning of test sample. The use of a clamping rod is optional. A section of pipe at least 6 in. (152 mm) in length is placed in the upright lateral branch. Pipe sections shall mate into the main body of the fitting so to prevent excessive deflection under load. A load equal to that in **Table 4** shall be placed on the upright section. There shall be no cracking or separation of the fitting, and the pipe spigot shall not ~~protrude~~ protrude into the waterway of the fitting.

10.4 ~~Internal Stress~~—~~Molded Internal Stress~~—Molded samples shall be tested in accordance with Test Method **F610/F610M** except the exposure time shall be a minimum of 30 min. The specimens shall be deemed to have failed if splitting, delamination, or weld line separation penetrates into the part more than 50 % of the wall thickness at the point of penetration.

10.5 Branch Bending:

10.5.1 *Forty-Five Degree Wyes*—The branch of a fabricated 45 degree wye fitting shall be subjected to a load as illustrated in **Fig.**