



Designation: C769 – 15 (Reapproved 2020)^{e1}

Standard Test Method for Sonic Velocity in Manufactured Carbon and Graphite Materials for Use in Obtaining an Approximate Value of Young's Modulus¹

This standard is issued under the fixed designation C769; the number immediately following the designation indicates the year of original adoption or, in the case of revision, the year of last revision. A number in parentheses indicates the year of last reapproval. A superscript epsilon (ϵ) indicates an editorial change since the last revision or reapproval.

^{e1} NOTE—Editorially updated 3.1.2 in December 2020.

1. Scope

1.1 This test method covers a procedure for measuring the sonic velocity in manufactured carbon and graphite which can be used to obtain an approximate value of Young's modulus.

1.2 The values stated in SI units are to be regarded as standard. No other units of measurement are included in this standard.

1.3 *This standard does not purport to address all of the safety concerns, if any, associated with its use. It is the responsibility of the user of this standard to establish appropriate safety, health, and environmental practices and determine the applicability of regulatory limitations prior to use.*

1.4 *This international standard was developed in accordance with internationally recognized principles on standardization established in the Decision on Principles for the Development of International Standards, Guides and Recommendations issued by the World Trade Organization Technical Barriers to Trade (TBT) Committee.*

2. Referenced Documents

2.1 ASTM Standards:²

C559 Test Method for Bulk Density by Physical Measurements of Manufactured Carbon and Graphite Articles

C747 Test Method for Moduli of Elasticity and Fundamental Frequencies of Carbon and Graphite Materials by Sonic Resonance

IEEE/ASTM SI 10 Standard for Use of the International System of Units (SI) (the Modern Metric System)

¹ This test method is under the jurisdiction of ASTM Committee D02 on Petroleum Products, Liquid Fuels, and Lubricants and is the direct responsibility of Subcommittee D02.F0 on Manufactured Carbon and Graphite Products.

Current edition approved Nov. 1, 2020. Published December 2020. Originally approved in 1980. Last previous edition approved in 2015 as C769 – 15. DOI: 10.1520/C0769-15R20E01.

² For referenced ASTM standards, visit the ASTM website, www.astm.org, or contact ASTM Customer Service at service@astm.org. For *Annual Book of ASTM Standards* volume information, refer to the standard's Document Summary page on the ASTM website.

3. Terminology

3.1 Definitions:

3.1.1 *elastic modulus, n* —the ratio of stress to strain, in the stress range where Hooke's law is valid.

3.1.2 *Young's modulus (E), n* —the elastic modulus in tension or compression.

3.2 Definitions of Terms Specific to This Standard:

3.2.1 *end correction time (T_e), n* —the non-zero time of flight (correction factor), measured in seconds, that may arise by extrapolation of the pulse travel time, corrected for zero time, back to zero sample length.

3.2.2 *longitudinal sonic pulse, n* —a sonic pulse in which the displacements are in the direction of propagation of the pulse.

3.2.3 *pulse travel time, (T_t), n* —the total time, measured in seconds, required for the sonic pulse to traverse the specimen being tested, and for the associated electronic signals to traverse the transducer coupling medium and electronic circuits of the pulse-propagation system.

3.2.4 *zero time, (T_0), n* —the travel time (correction factor), measured in seconds, associated with the transducer coupling medium and electronic circuits in the pulse-propagation system.

4. Summary of Test Method

4.1 The velocity of longitudinal sound waves passing through the test specimen is determined by measuring the distance through the specimen and dividing by the time lapse, between the transmitted pulse and the received pulse.^{3,4} Provided the wavelength of the transmitted pulse is a sufficiently small fraction of the sample lateral dimensions, a value of Young's modulus for isotropic graphite can then be obtained using Eq 1 and Eq 2:

$$E = C_v \rho V^2 \quad (1)$$

³ Schreiber, Anderson, and Soga, *Elastic Constants and Their Measurement*, McGraw-Hill Book Co., 1221 Avenue of the Americas, New York, NY 10020, 1973.

⁴ *American Institute of Physics Handbook*, 3rd ed., McGraw-Hill Book Co., 1221 Avenue of the Americas, New York, NY 10020, 1972, pp. 3–98ff.

where:

- E = Young's modulus of elasticity, Pa,
 ρ = density, kg/m³,
 V = longitudinal signal velocity, m/s, and
 C_v = Poisson's factor.

The Poisson's factor, C_v , is related to Poisson's ratio, ν , by the equation:

$$C_v = \frac{(1+\nu)(1-2\nu)}{1-\nu} \quad (2)$$

If Poisson's ratio is unknown, it can be assumed as an approximation in the method. For nuclear graphites, a typical Poisson's ratio of 0.2 corresponds to a Poisson's factor of 0.9.

If the wavelength is not a small fraction of the sample lateral dimensions, and instead is much larger than the specimen lateral dimensions, then the Young's modulus, E is given by Eq 1 with C_v set to one rather than being determined by Eq 2.

5. Significance and Use

5.1 Sonic velocity measurements are useful for comparing materials with similar elastic properties, dimensions, and microstructure.

5.2 Eq 1 provides an accurate value of Young's modulus only for isotropic, non-attenuative, and non-dispersive materials of infinite dimensions. For non-isotropic graphite, Eq 1 can be modified to take into account the Poisson's ratios in all directions. As graphite is a strongly attenuative material, the value of Young's modulus obtained with Eq 1 will be dependent on specimen length. If the specimen lateral dimensions are not large compared to the wavelength of the propagated pulse, then the value of Young's modulus obtained with Eq 1 will be dependent on the specimen lateral dimensions. The accuracy of the Young's modulus calculated from Eq 1 will also depend upon the uncertainty in Poisson's ratio and its impact on the evaluation of the Poisson's factor in Eq 2. However, a value for Young's modulus can be obtained for many applications, which is often in good agreement with the value obtained by other more accurate methods, such as in Test Method C747. The technical issues and typical values of corresponding uncertainties are discussed in detail in STP 1578.⁵

5.3 If the grain size of the carbon or graphite is greater than or about equal to the wavelength of the sonic pulse, the method may not be providing a value of Young's modulus representative of the bulk material. Therefore, it would be recommended to test a lower frequency (longer wavelength) to demonstrate that the range of obtained velocity values are within an acceptable level of accuracy. Significant signal attenuation should be expected when the grain size of the material is greater than or about equal to the wavelength of the transmitted sonic pulse or the material is more porous than would be expected for an as-manufactured graphite.

NOTE 1—Due to frequency dependent attenuation in graphite, the wavelength of the sonic pulse through the test specimen is not necessarily

the same as the wavelength of the transmitting transducer.

5.4 If the sample is only a few grains thick, the acceptability of the method's application should be demonstrated by initially performing measurements on a series of tests covering a range of sample lengths between the proposed test length and a test length incorporating sufficient grains to adequately represent the bulk material.

6. Apparatus

6.1 *Driving Circuit*, consisting of an ultrasonic pulse generator.

6.1.1 The user should select a pulse frequency to suit the material microstructure and specimen elastic properties and dimensions being tested. High frequencies are attenuated by carbon and graphite materials and, while typical practicable frequencies lie in the range 0.5 MHz to 2.6 MHz, the user may show that frequencies outside this range are acceptable.

6.2 *Transducer*, input, with suitable coupling medium (see 8.5).

6.3 *Transducer*, output, with suitable coupling medium (see 8.5).

6.3.1 The signal output will depend upon the characteristics of the chosen transducers and pulser-receiver and the test material. It is recommended that the user analyses the input and output frequency spectra to determine optimum conditions. Band pass filters and narrow band transducers may be used to simplify the signal output which could improve the measurement of the time of flight.

6.4 *Computer*, with analogue to digital converter, or oscilloscope, and external trigger from driving circuit.

6.5 See Fig. 1 for a typical schematic setup.

NOTE 2—Some manufacturers combine items 6.1 and 6.4 into a single package with direct time readout. Such apparatus can operate satisfactorily, provided the frequency of the propagated pulse is already known, in order to check that wavelength requirements for the method are satisfied.

7. Test Specimen

7.1 *Selection and Preparation of Specimens*—Take special care to assure obtaining representative specimens that are straight, uniform in cross section, and free of extraneous liquids. The specimen end faces shall be perpendicular to the specimen cylindrical surface to within 0.125 mm total indicator reading.

7.2 *Measurement of Weight and Dimensions*—Determine the weight and the average specimen dimensions to within $\pm 0.2\%$.

7.3 *Limitations on Dimensions*—These cannot be precisely specified as they will depend upon the properties of the material being tested and the experimental setup (for example, transducer frequency). In order to satisfy the theory that supports Eq 1, as a guide, the specimen should have a diameter that is at least a factor five, greater than the wavelength of sound in the material under test. In practice, the length of the specimen will be determined taking account of the comments in 5.3 and 5.4.

⁵ ASTM Selected Technical Papers, STP 1578, *Graphite Testing for Nuclear Applications: The Significance of Test Specimen Volume and Geometry and the Statistical Significance of Test Specimen Population*, 2014, edited by Tzelepi and Carroll.

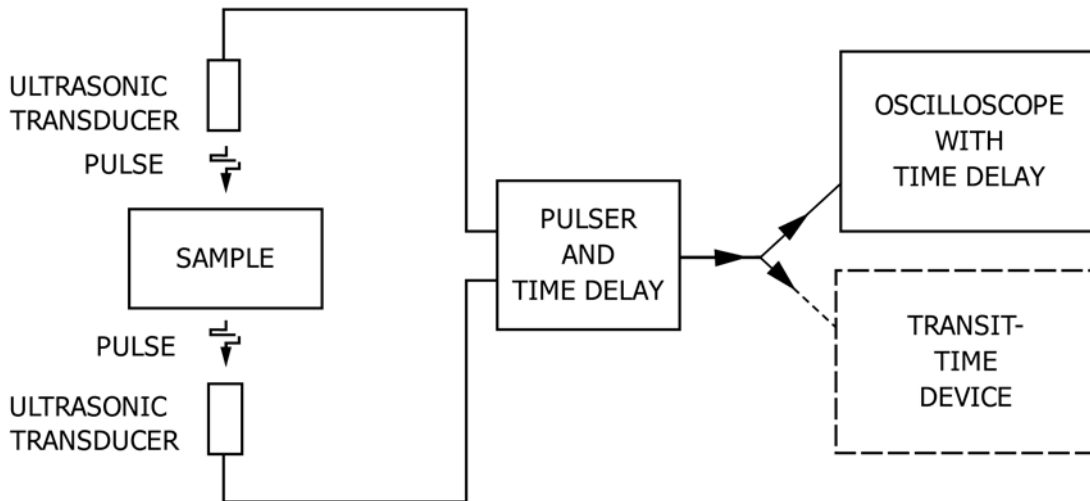

FIG. 1 Basic Experimental Arrangement for the Ultrasonic Pulsed-Wave Transit Time Technique

7.4 *Limitations on Ultrasonic Pulse Frequency*—Generally speaking, a better accuracy of time of flight will be obtained at higher frequencies. However, attenuation increases at higher frequencies leading to weak and distorted signals.

8. Procedure

8.1 For any given apparatus and choice of coupling medium, it is necessary to follow procedures to quantify the zero time, T_0 , and end correction time, T_e , correction factors. T_0 will be dependent upon the type of transducers and their performance over time and should be regularly checked (see 8.8). It must be quantified if the test setup is changed. T_e should be small and reflects the interaction between the coupling medium and the test material. T_e should be determined once for a specific measurement setup and test material.

8.1.1 Determine whether an end correction time, T_e , is evident in the time of flight by performing time of flight measurements on various length samples taken from a single bar. As modulus is likely to vary from sample to sample the recommended approach is to continually bisect a long rod, measuring each bi-section, until the required lower limit is reached. The end correction time, T_e , is obtained from a regression fit to a graph of time of flight versus sample length.

8.2 Measure and weigh the test specimen as in 7.2.

8.3 Calculate the density of the test specimen in accordance with Test Method C559.

8.4 Connect the apparatus as shown in Fig. 1, and refer to equipment manufacturer’s instructions for setup precautions. Allow adequate time for equipment warm-up and stabilization.

8.5 Place the transducers against the test specimen end faces.

8.5.1 A coupling medium may be necessary to improve transmission of the sonic pulse. In this case, apply a light coating of the coupling medium to the faces of the test specimens that will contact the transducers. Alternatively, rubber-tipped transducers can be effective if a fully noninvasive measurement is needed.

NOTE 3—The following coupling media may be used: hydroxyethyl

cellulose, petroleum jelly, high vacuum greases and water-based ultrasonic couplants. However these may be difficult to remove subsequently. Distilled water can provide a very satisfactory coupling medium without significant end effects, and surface water may be removed subsequently by drying. Manufacturers offer rubber-tipped transducers suitable for noninvasive measurements. With these transducers either good load control or accurate determination of the rubber length is essential during measurement if good reproducibility is to be achieved.

8.6 Bring transducer faces into intimate contact but do not exceed manufacturer’s recommended contact pressures.

8.7 Follow the vendor’s instructions to adjust the instrumentation to match the transducer frequency to give good visual amplitude resolution.

8.8 Determine T_0 , the travel time (zero correction) measured in seconds, associated with the electronic circuits in the pulse-propagation instrument and coupling (Fig. 2(a)). Ensure that the repeatability of the measurement is of sufficient precision to meet the required accuracy in Young’s modulus.

8.9 Adjust the gain of electronic components to give good visual amplitude resolution.

8.10 Determine T_t , the total traverse time from the traces (Fig. 2(b)). Ensure that the repeatability of the measurement is of sufficient precision to meet the required accuracy in Young’s modulus.

8.11 It is good practice to monitor the performance and reproducibility of the sonic velocity equipment by periodically testing a reference sample of similar material and geometry to that typically used by the operator. This will monitor drift arising from deterioration in transducer performance. Standards need to be representative of the material being tested and have a similar geometry.

9. Calculation

9.1 *Velocity of Signal:*

$$V = \frac{L}{T_t - T_0 - T_e} \quad (3)$$

where:

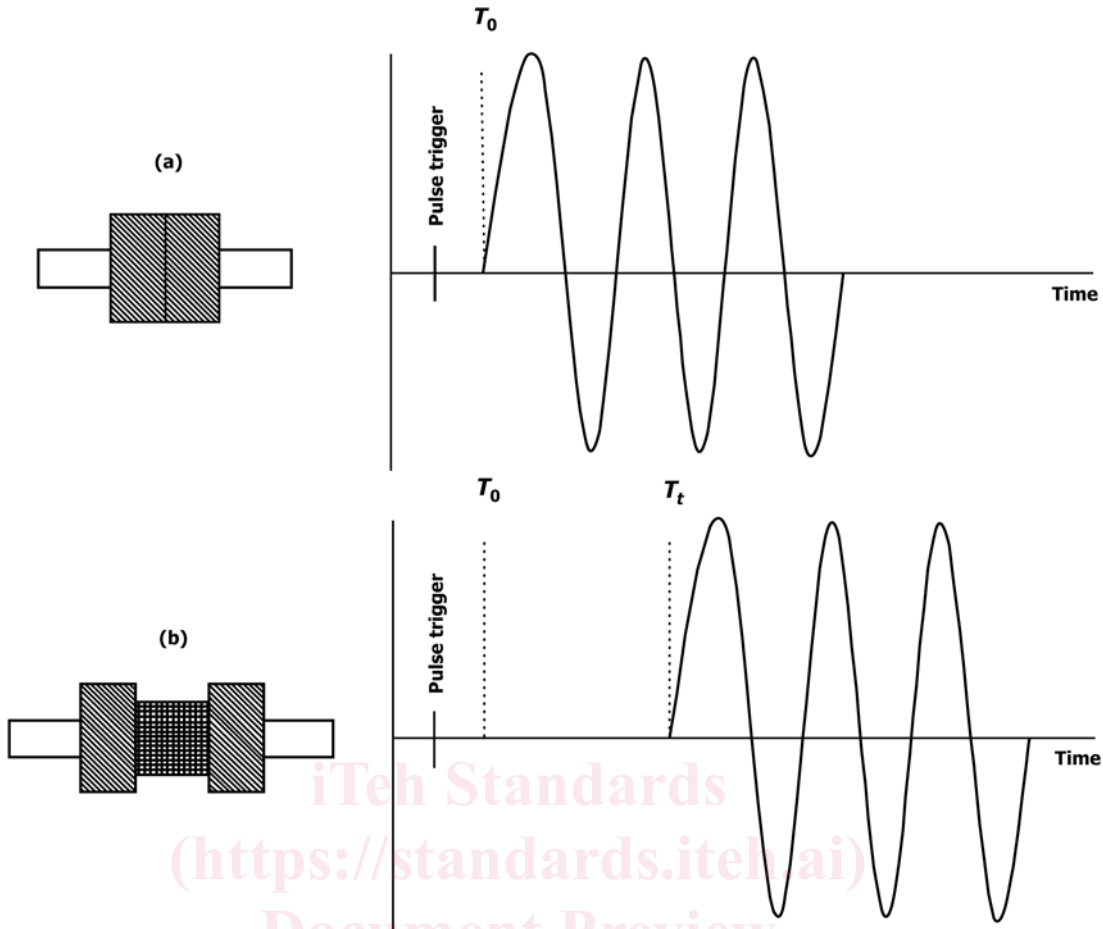

FIG. 2 Schematic Illustrating (a) Zero Time (T_0) Measurement for Face to Face Contact Between Transducers and (b) Pulse Travel Time (T_t) Measurement for the Sample Positioned Between the Transducers, based upon a Simplified Received Wave Signal and the Idealized Case where the Onset of the First Peak has been Detected

ASTM C 769-15(2020)e1

[https://standards.iteh.ai/catalog/standards/sist/1ef04760-d194-465a-9e91-87fb1ddb8c4d/astm-c-769-15\(2020\)e1](https://standards.iteh.ai/catalog/standards/sist/1ef04760-d194-465a-9e91-87fb1ddb8c4d/astm-c-769-15(2020)e1) 9.3 Conversion Factors—See IEEE/ASTM SI 10.

- V = velocity of signal, m/s,
- L = specimen length, m,
- T_t = traverse time, s,
- T_0 = zero time, s, and
- T_e = end correction time, s.

9.2 Since graphites are not necessarily isotropic, the value of Young’s modulus cannot be determined solely from a velocity measurement in one direction. However, an approximate Young’s modulus for each direction may be obtained using Eq 4 (based upon an assumed Poisson’s ratio of 0.2). More accurate estimates of the Young’s moduli require the determination of the full compliance matrix from a set of measurements of longitudinal and shear wave velocities along principal axes together with measurements of a sonic velocity at 45° to the principal axes.

$$E \cong 0.9 \rho V^2 \quad (4)$$

where:

- E = Young’s modulus, Pa (approximate),
- ρ = density, kg/m³, and
- V = velocity of sound, m/s.

10. Report

10.1 The report shall include the following:

10.1.1 The wavelength or frequency of the transmitted pulse and sonic velocity equipment identification.

NOTE 4—Due to the strong frequency dependent attenuation of ultrasound in graphite, the frequency of the transmitted pulse may be completely different from the nominal ultrasonic transducer frequency.

10.1.2 Specimen dimensions, weight, and test specimen orientation with respect to forming direction.

10.1.3 Sonic velocity for each specimen, along with a description of the method of time of flight determination.

10.1.4 Density of each specimen, if calculated.

10.1.5 Young’s modulus of each specimen, if calculated.

10.1.6 It is recommended that average and standard deviation values be included for each group of specimens.

10.1.7 Environmental conditions of test, including temperature, humidity, and special atmosphere (if used).

10.1.8 Method of coupling the transducers to the specimen along with any end correction times used.