



Designation: E1685 – 20

Standard Practice for Measuring the Change in Length of Bolts Using the Ultrasonic Pulse-Echo Technique¹

This standard is issued under the fixed designation E1685; the number immediately following the designation indicates the year of original adoption or, in the case of revision, the year of last revision. A number in parentheses indicates the year of last reapproval. A superscript epsilon (ϵ) indicates an editorial change since the last revision or reapproval.

1. Scope*

1.1 This practice covers a procedure for measuring changes in length of threaded bolts using the ultrasonic pulse-echo technique.

1.2 This procedure is normally intended for metal bolting 6.3 mm or more in nominal diameter with effective length-to-diameter ratios of 2:1 or greater.

1.3 The values stated in SI units are to be regarded as standard. No other units of measurement are included in this standard.

1.4 *This standard does not purport to address all of the safety concerns, if any, associated with its use. It is the responsibility of the user of this standard to establish appropriate safety, health, and environmental practices and determine the applicability of regulatory limitations prior to use.*

1.5 *This international standard was developed in accordance with internationally recognized principles on standardization established in the Decision on Principles for the Development of International Standards, Guides and Recommendations issued by the World Trade Organization Technical Barriers to Trade (TBT) Committee.*

2. Referenced Documents

2.1 *ASTM Standards:*²

[E6 Terminology Relating to Methods of Mechanical Testing](#)
[E111 Test Method for Young's Modulus, Tangent Modulus, and Chord Modulus](#)

[E1316 Terminology for Nondestructive Examinations](#)

[E1544 Practice for Construction of a Stepped Block and Its Use to Estimate Errors Produced by Speed-of-Sound](#)

[Measurement Systems for Use on Solids \(Withdrawn 2012\)](#)³

3. Terminology

3.1 The definitions of calibration, extensometer system, metrological traceability, reference standard, testing machine, and verification, in this practice are used as defined in Terminology [E6](#).

3.2 The definitions of attenuation, couplant, echo, longitudinal wave, pulse, pulse echo method, reference block, reflector, resolution, time-of-flight, transducer, and ultrasonic are used as defined in Section I of Terminology [E1316](#).

3.3 *Definitions of Terms Specific to This Standard:*

3.3.1 *change in length [L], n*—physical change in length of a threaded fastener due to a change in tension within the fastener.

3.3.2 *effective length [L], n*—the length of a bolt that is responsive to stress, defined here as the bolt length between head and nut plus half the thickness of the head plus half the thickness of the nut..

3.3.3 *pulse-echo bolt-measuring instrument*—an assembly of ultrasonic instruments designed specifically to measure changes in the lengths of bolts. See [Appendix X1](#).

3.3.4 *reference length [L], n*—the ultrasonic time-of-flight in the test specimen multiplied by a reference propagation velocity.

3.3.4.1 *Discussion*—The reference propagation velocity is the velocity of propagation of the ultrasonic wavefront in a calibration test block or in the bolts whose changes of length are being measured.

4. Summary of Practice

4.1 This practice describes a procedure for determining the change in length of a threaded fastener due to a change in tension in the fastener. Measurements of the ultrasonic time-of-flight are made before and after the fastener tension is changed, and a calculation of the change in length is made from the change in the time-of-flight.

³The last approved version of this historical standard is referenced on www.astm.org.

¹ This practice is under the jurisdiction of ASTM Committee [E28](#) on Mechanical Testing and is the direct responsibility of Subcommittee [E28.13](#) on Residual Stress Measurement.

Current edition approved Oct. 1, 2020. Published December 2020. Originally approved in 1995. Last previous edition approved in 2013 as E1685–13. DOI: 10.1520/E1685-20.

² For referenced ASTM standards, visit the ASTM website, www.astm.org, or contact ASTM Customer Service at service@astm.org. For *Annual Book of ASTM Standards* volume information, refer to the standard's Document Summary page on the ASTM website.

*A Summary of Changes section appears at the end of this standard

4.1.1 Brief bursts of ultrasound (pulses) are generated by applying high-voltage electrical signals to an electroacoustic transducer having a resonant frequency in the 1 MHz to 10-MHz range (typical). The pulses enter the bolt through the transducer/bolt interface, travel to the far end of the bolt, and reflect back (echo) to the transducer. The time-of-flight required for the signal to make its round-trip is measured electronically. By measuring the change in the time-of-flight due to a change in tension within the bolt and compensating for the direct effect of stress on the propagation velocity in the bolt the change in length of the bolt due to the change in tension can be determined.

4.2 This procedure is used on fasteners as they are tightened within their elastic limits; or on previously tightened fasteners as they are loosened. The latter can have been tightened past yield.

5. Significance and Use

5.1 The techniques described provide for the measurement of change in length of a fastener. Such measurements are made from one end of the specimen without requiring access to the rear surface.

5.2 The Ultrasonic Pulse Echo technique is used to monitor changes in length of fasteners and as a tool for industrial quality control. Applications include fasteners used in turbines, petrochemical pressure vessels, aircraft, automotive manufacturing, general bolting within the nuclear industry, structural steel connections, and laboratory testing.

6. Apparatus

6.1 *Pulse-echo bolt-measuring instrument*—For ultrasonic measurements of the change in length of bolts, the pulse-echo bolt-measuring instrument shall be capable of determining the calculated change in length to the accuracy and precision requirements set forth in [Annex A1](#). The major components of suitable instruments are as follows:

6.1.1 *Pulser/transmitter*, a means of generating electrical pulses to excite an ultrasonic transducer.

6.1.2 *Receiver*, a means of amplifying the returning back-wall echo.

6.1.3 *Time-base Controller*, a means of measuring changes in ultrasonic time-of-flight.

6.1.4 *Data analysis computer*, a computer or microprocessor for processing the ultrasonic data for determination of the material stress level from the measured fastener strain.

6.1.4.1 The pulser/transmitter, receiver/detector, time-base controller, and computer may be integrated into a unified system or instrumented together from separate components.

6.1.5 *Ultrasonic Transducer*, a means of sending and receiving ultrasonic waves. The resonance of the transducer should be in the range 1MHz to 10 MHz.

NOTE 1—The choice of transducer frequency is determined by the length of fastener under investigation and dependent on two primary factors: signal clarity and attenuation.

6.1.5.1 The ultrasonic frequency should be high enough to produce an ultrasonic pulse that is sufficiently short so that the ultrasonic reflections from the far end of the fastener occurs after the ultrasonic reflection from entry surface has ended.

6.1.5.2 Conversely, the frequency should be low enough so that the signal reflected from the far end of the fastener is large enough for successful detection.

NOTE 2—In general, short fasteners require higher frequency, whereas long fasteners require low frequencies.

6.1.5.3 The diameter of the ultrasonic transducer should be as large as possible, but shall not be larger than the minimum body diameter of the bolt.

6.1.6 Pulse-echo bolt-measuring instruments are designed to measure and report the change in length of a bolt to the nearest 0.0025 mm or 0.00025 mm. To do this the instrument resolution shall be 0.0012 mm or 0.00012 mm.

NOTE 3—This degree of precision is required because a typical bolt tightened to yield will stretch only about 0.003 mm/mm of grip length.

6.2 Other Apparatus:

6.2.1 *Couplant*—a liquid or glue that couples ultrasound between the transducer and the fastener.

NOTE 4—A 50/50 glycerine/water mix, light oil or standard commercially available couplants and glues can provide satisfactory results.

7. Procedure

7.1 The performance of the pulse-echo bolt-measuring instrument should be calibrated to a reference standard in accordance with [Annex A1](#).

7.1.1 In noncritical applications, where uncertainties greater than $\pm 3\%$ of the change in length are acceptable, an instrument calibrated on one bolt of a given material may be used on other bolts of the same material but having different shapes.

7.1.2 In critical, safety-related applications or where uncertainties of less than 3% are required, or both, the pulse-echo bolt-measuring instrument should be recalibrated on a statistically significant sample of each new lot of bolts.

7.2 *Fastener Preparation*—The finish and geometry of the fastener shall be prepared to ensure reliable ultrasonic measurements. One end shall be accessible for transducer placement. This end shall, for at least the diameter of the transducer, be flat and perpendicular to the axis of the bolt. Any raised grade markings should be removed. If the end is recessed it shall have a flat spot face. The surface of the reflector end of the fastener shall be flat and parallel to the other end. The amount of axial runout on the end depends on fastener size and the accuracy requirement. An area as small as 3 mm in diameter may be sufficient.

7.2.1 The ends of bolts with through center holes may be prepared adjacent to the holes, with the transducer locations marked, as illustrated in [Fig. 1](#).

7.2.2 Do not remove grade markings indiscriminately. Document and maintain grade marking removals.

7.3 Measure average fastener temperature with an error less than 1 °C.

7.4 Transducer Placement:

7.4.1 Apply a suitable acoustic couplant to allow adequate sound transmission. A high-viscosity couplant should be used if the fastener has indented grade markings or if its surface has a few pits.

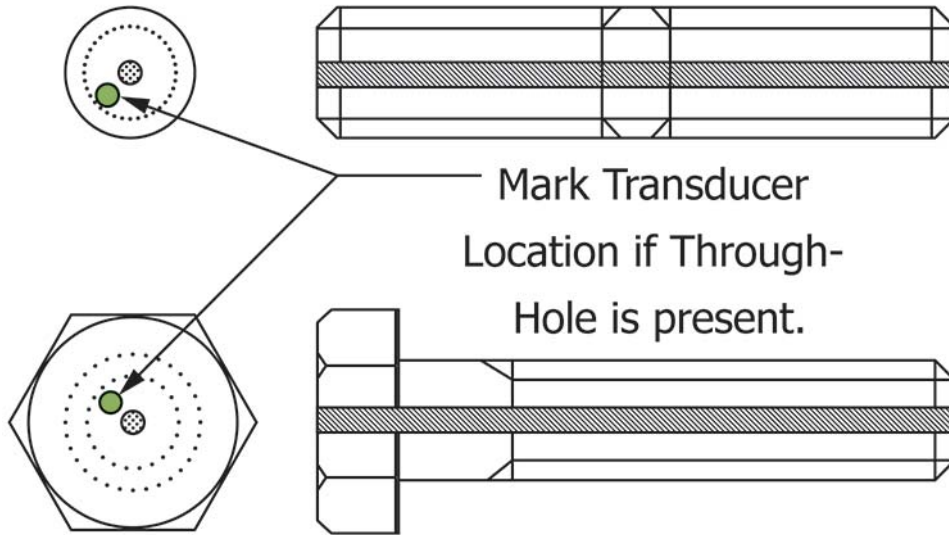

FIG. 1 Example Transducer Location Markings on Bolts with a Central Hole

7.4.2 Wipe the coupling surface to remove excess couplant. The amount of couplant shall be sufficient to wet the transducer face, but not be excessive. Use consistent amounts for successive or repetitive readings.

7.4.3 Place the transducer on the flat surface of the bolt to be measured. To minimize possible impact damage to the wear-plate portion of the transducer, set it down on its edge and then carefully rotate it into a flat position. Seat the transducer by light, back-and-forth finger movements to squeeze out excess couplant and to obtain the shortest, most stable, length display, or the largest echo signal on the oscilloscope. Repeat this process several times to ensure repeatability.

7.4.4 To ensure repeatable readings always return the transducer to the same position during the measurement process. This location may be marked on the end of the fastener, and the identification/serial number may be noted for a relative position. See [Appendix X2](#).

7.5 Obtain the reference length of the fastener in either the untensioned or tensioned condition. Record the reference length for future comparisons. Ensure that the fastener in the untensioned condition is physically loose.

7.6 If the reference length was determined in the untensioned condition, tighten the fastener. If the reference length was determined in the tensioned condition, unload the fastener.

7.7 Measure the change in length of the fastener and record the value.

7.8 Additional measurements may be made at any time in the future by following [7.1](#), [7.3](#), [7.4](#), and [7.7](#), and using the reference length as measured in accordance with [7.5](#).

8. Report

8.1 The following data shall be included in the test report:

8.1.1 Type of material measured.

8.1.2 The calibration factors in use by the test equipment including the stress factor, the material velocity, and the temperature factor. See [Annex A1](#).

8.1.3 Transducer size, frequency, and serial number.

8.1.4 Model and serial numbers of the pulse-echo bolt-measuring instrument and reference blocks, if applicable.

8.1.5 Reference length (in millimetres) and the temperature at the time of measurement.

8.1.6 Change in length (in millimetres) and the temperature at the time of measurement.

9. Keywords

9.1 bolts; change-in-length measurements; stress measurements; ultrasonics.