



Designation: D2649 – 20a

Standard Test Method for Corrosion Characteristics of Solid Film Lubricants¹

This standard is issued under the fixed designation D2649; the number immediately following the designation indicates the year of original adoption or, in the case of revision, the year of last revision. A number in parentheses indicates the year of last reapproval. A superscript epsilon (ϵ) indicates an editorial change since the last revision or reapproval.

This standard has been approved for use by agencies of the U.S. Department of Defense.

1. Scope*

1.1 This test method² covers the evaluation of the galvanic and environmental corrosion interaction characteristics of dry solid film lubricants when in contact with an aluminum surface under conditions of high humidity.

1.2 The values stated in SI units are to be regarded as the standard. The inch-pound units given in parentheses are for information only.

1.3 *This standard does not purport to address all of the safety concerns, if any, associated with its use. It is the responsibility of the user of this standard to establish appropriate safety, health, and environmental practices and determine the applicability of regulatory limitations prior to use.*

1.4 *This international standard was developed in accordance with internationally recognized principles on standardization established in the Decision on Principles for the Development of International Standards, Guides and Recommendations issued by the World Trade Organization Technical Barriers to Trade (TBT) Committee.*

2. Referenced Documents

2.1 ASTM Standards:³

[B209 Specification for Aluminum and Aluminum-Alloy Sheet and Plate](#)

[B308/B308M Specification for Aluminum-Alloy 6061-T6 Standard Structural Profiles](#)

[D235 Specification for Mineral Spirits \(Petroleum Spirits\) \(Hydrocarbon Dry Cleaning Solvent\)](#)

[D1730 Practices for Preparation of Aluminum and Aluminum-Alloy Surfaces for Painting](#)

[D1748 Test Method for Rust Protection by Metal Preservatives in the Humidity Cabinet](#)

[D2247 Practice for Testing Water Resistance of Coatings in 100 % Relative Humidity](#)

2.2 *U. S. Military Specifications:*⁴

[MIL-PRF-680 Degreasing Solvent](#)

[MIL-PRF-3043 Resin-Coating, Permanent, for Engine Components and Metal Parts](#)

2.3 *Other Standards:*⁵

[SAE AS5272 Lubricant, Solid Film, Heat Cured, Corrosion Inhibiting, Procurement Specification](#)

3. Terminology

3.1 Definitions:

3.1.1 *lubricant, n*—any material interposed between two surfaces that reduces the friction or wear, or both, between them.

3.2 Definitions of Terms Specific to This Standard:

3.2.1 *dry solid film lubricant, n*—on an aluminum surface, one consisting of friction-reducing powders bonded in tight matrix to the surface of the metal.

4. Summary of Test Method

4.1 An aluminum panel having solid film deposited on one surface is contacted under load with the surface of an unlubricated panel. The specimen is subjected to 95 % \pm 3 % relative humidity at 49 °C (120 °F) for a period of 500 h. After this period, the surface of the unlubricated panel is examined for evidence of corrosion.

5. Significance and Use

5.1 Surfaces are examined for signs of corrosion. Any sign of corrosion is an indication of potential field failure.

6. Apparatus

6.1 *Bolt and Nut*, Finished hex bolt, $\frac{3}{8}$ -24, minimum 19 mm ($\frac{3}{4}$ in.) long and finished hex nut, $\frac{3}{8}$ -24. Bolt and nut shall be

¹ This test method is under the jurisdiction of ASTM Committee D02 on Petroleum Products, Liquid Fuels, and Lubricants and is the direct responsibility of Subcommittee D02.L0.05 on Solid Lubricants.

Current edition approved Dec. 1, 2020. Published December 2020. Originally approved in 1967. Last previous edition approved in 2020 as D2649 – 20. DOI: 10.1520/D2649-20A.

² Reference may be made to Military Specification MIL-L-8937 (ASG), Jan. 22, 1963, and Method 3814 of Federal Test Method Standard No. 791.

³ For referenced ASTM standards, visit the ASTM website, www.astm.org, or contact ASTM Customer Service at service@astm.org. For *Annual Book of ASTM Standards* volume information, refer to the standard's Document Summary page on the ASTM website.

⁴ Available from Standardization Documents Order Desk, Bldg. 4 Section D, 700 Robbins Ave., Philadelphia, PA 19111-5094, Attn: NPODS.

⁵ Available from SAE International (SAE), 400 Commonwealth Dr., Warrendale, PA 15096, <http://www.sae.org>.

*A Summary of Changes section appears at the end of this standard

made of corrosion-resistant aluminum or stainless steel. Two (2) nuts and two (2) bolts are required.

6.2 *Channel*, made of aluminum alloy 6061-T6, conforming to Specification B308/B308M, 76 mm (3 in.) wide, 36 mm (1.41 in.) high, cut to 178 mm (7 in.) long. Holes for the bolts to pass through are drilled on the centerline of the channel 25 mm (1 in.) from each end. Two (2) channels are required.

6.3 *Humidity Environmental Test Chamber*, capable of producing 95 % ± 3 % relative humidity, 49 °C ± 1 °C (120 °F ± 2 °F), and conforming to Test Method D1748, Annex A1 on Humidity Cabinet Apparatus or Test Method D2247, Annex A1 on Apparatus.

6.4 *Torque Wrench*, with capacity of 2.8 N·m (25 lb·in.).

6.5 *Micrometer*, reading 0 mm to 25 mm ± 0.002 mm (0 in. to 1 in. ± 0.0001 in.) with a spherical anvil.

6.6 *Forced-Circulation Oven*, capable of maintaining a temperature of 66 °C ± 3 °C (150 °F ± 5 °F) and 149 °C ± 5.5 °C (300 °F ± 10 °F).

7. Reagents and Materials

7.1 *Panels*, made of aluminum alloy 2024, conforming to Specification B209, 76 mm by 152 mm by 0.5 mm (3 in. by 6 in. by 0.020 in.) thick, anodized in accordance with Practices D1730, Type C, Method 1.

NOTE 1—Other metals and alloys, with other methods of surface pretreatment, may be used in this test method for special purpose. Such deviations shall become a part of the report, 10.1.

7.2 *Dry Cleaning Solvent*, conforming to Specification D235 or Federal Specification MIL-PRF-680.

7.3 *Resin Coating*, permanent (for internal engine parts), conforming to Military Specification MIL-PRF-3043.

8. Sampling, Test Specimens, and Test Units

8.1 Be certain there is sufficient quantity of solid film lubricant mixture to perform the test.

8.2 Prepare the apparatus and specimens as follows:

8.2.1 Liquid degrease the aluminum channel, nuts, bolts, and test panels with hydrocarbon dry cleaning solvent (see 7.2).

8.2.2 Deposit a film of resin coating on the surface of the aluminum channel and cure in accordance with the manufacturer’s specification.

8.2.3 Apply solid film lubricant to the surface of the panel by spraying or equivalent method to produce a dry film thickness between 0.005 mm and 0.013 mm (0.0002 in. and 0.0005 in.).

8.2.4 In most cases, curing will be according to the particular manufacturer’s specifications. If such instructions are not provided, cure the film by air drying for 6 h at 26.7 °C ± 3 °C (80 °F ± 5 °F) or by air drying for 30 min at 26.7 °C followed by 1 h in an air-circulating oven at 149 °C ± 5.5 °C (300 °F ± 10 °F).

8.2.5 Measure the dry film thickness using a micrometer.

9. Procedure

9.1 Arrange the panels (see Fig. 1) by placing a coated panel against an uncoated panel at a 90° angle to each other; place them between the aluminum channel, insert the bolts, and tighten the nut and bolt combination to a constant load of 2.8 N·m (25 lb·in.) using a torque wrench. Discard any nuts or bolts that show evidence of corrosion that might lessen the effect of the tightening torque.

9.2 Run a blank assembly with uncoated panels concomitantly with each set of samples as a check on the whole process of panel preparation and for comparison during reporting, 10.2.

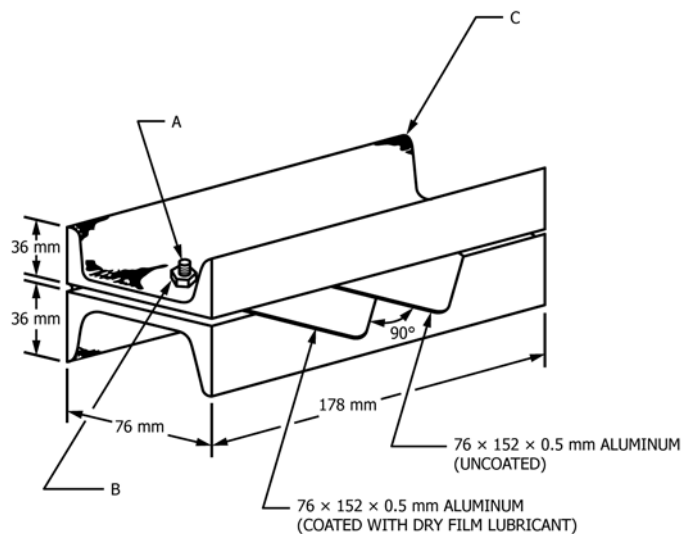

A—Bolt 5/8 –24 UNF–3A

B—Nut 5/8 –24 UNF–3B

C—Aluminum channel coated with resin coating conforming to Military Specification Mil-PRF-3043. (Resin shall be cured in accordance with the manufacturer’s specifications.)

FIG. 1 Corrosion Test Jig