



Designation: E511 – 07 (Reapproved 2020)

Standard Test Method for Measuring Heat Flux Using a Copper-Constantan Circular Foil, Heat-Flux Transducer¹

This standard is issued under the fixed designation E511; the number immediately following the designation indicates the year of original adoption or, in the case of revision, the year of last revision. A number in parentheses indicates the year of last reapproval. A superscript epsilon (ϵ) indicates an editorial change since the last revision or reapproval.

1. Scope

1.1 This test method describes the measurement of radiative heat flux using a transducer whose sensing element (**1, 2**)² is a thin circular metal foil. These sensors are often called Gardon Gauges.

1.2 The values stated in SI units are to be regarded as the standard. The values stated in parentheses are provided for information only.

1.3 *This standard does not purport to address all of the safety concerns, if any, associated with its use. It is the responsibility of the user of this standard to establish appropriate safety, health, and environmental practices and determine the applicability of regulatory limitations prior to use.*

1.4 *This international standard was developed in accordance with internationally recognized principles on standardization established in the Decision on Principles for the Development of International Standards, Guides and Recommendations issued by the World Trade Organization Technical Barriers to Trade (TBT) Committee.*

2. Summary of Test Method

2.1 The purpose of this test method is to facilitate measurement of a radiant heat flux. Although the sensor will measure heat fluxes from mixed radiative – convective or pure convective sources, the uncertainty will increase as the convective fraction of the total heat flux increases.

2.2 The circular foil heat flux transducer generates a millivolt output in response to the rate of thermal energy absorbed (see Fig. 1). The perimeter of the circular metal foil sensing element is mounted in a metal heat sink, forming a reference thermocouple junction due to their different thermoelectric potentials. A differential thermocouple is created by a second thermocouple junction formed at the center of the foil using a

¹ This test method is under the jurisdiction of ASTM Committee E21 on Space Simulation and Applications of Space Technology and is the direct responsibility of Subcommittee E21.08 on Thermal Protection.

Current edition approved Nov. 1, 2020. Published December 2020. Originally approved in 1973. Last previous edition approved in 2015 as E511 – 07(2015). DOI: 10.1520/E0511-07R20.

² The boldface numbers in parentheses refer to the list of references at the end of this standard.

fine wire of the same metal as the heat sink. When the sensing element is exposed to a heat source, most of the heat energy absorbed at the surface of the circular foil is conducted radially to the heat sink. If the heat flux is uniform and heat transfer down the center wire is neglected, a parabolic temperature profile is established between the center and edge of the foil under steady-state conditions. The center – perimeter temperature difference produces a thermoelectric potential, E , that will vary in proportion to the absorbed heat flux, q' . With prescribed foil diameter, thickness, and materials, the potential E is almost linearly proportional to the average heat flux q' absorbed by the foil. This relationship is described by the following equation:

$$E = Kq' \quad (1)$$

where:

K = a sensitivity constant determined experimentally.

2.3 For nearly linear response, the heat sink and the center wire of the transducer are made of high purity copper and the foil of thermocouple grade Constantan. This combination of materials produces a nearly linear output over a gauge temperature range from -45 to 232 °C (-50 to 450 °F). The linear range results from the basically offsetting effects of temperature-dependent changes in the thermal conductivity and the Seebeck coefficient of the Constantan (**3**). All further discussion is based on the use of these two metals, since engineering practice has demonstrated they are commonly the most useful.

3. Description of the Instrument

3.1 Fig. 1 is a sectional view of an example circular foil heat-flux transducer. It consists of a circular Constantan foil attached by a metallic bonding process to a heat sink of oxygen-free high conductivity copper (OFHC), with copper leads attached at the center of the circular foil and at any point on the heat-sink body. The transducer impedance is usually less than 1 V. To minimize current flow, the data acquisition system (DAS) should be a potentiometric system or have an input impedance of at least 100 000 Ω .

3.2 As noted in 2.3, an approximately linear output (versus heat flux) is produced when the body and center wire of the transducer are constructed of copper and the circular foil is

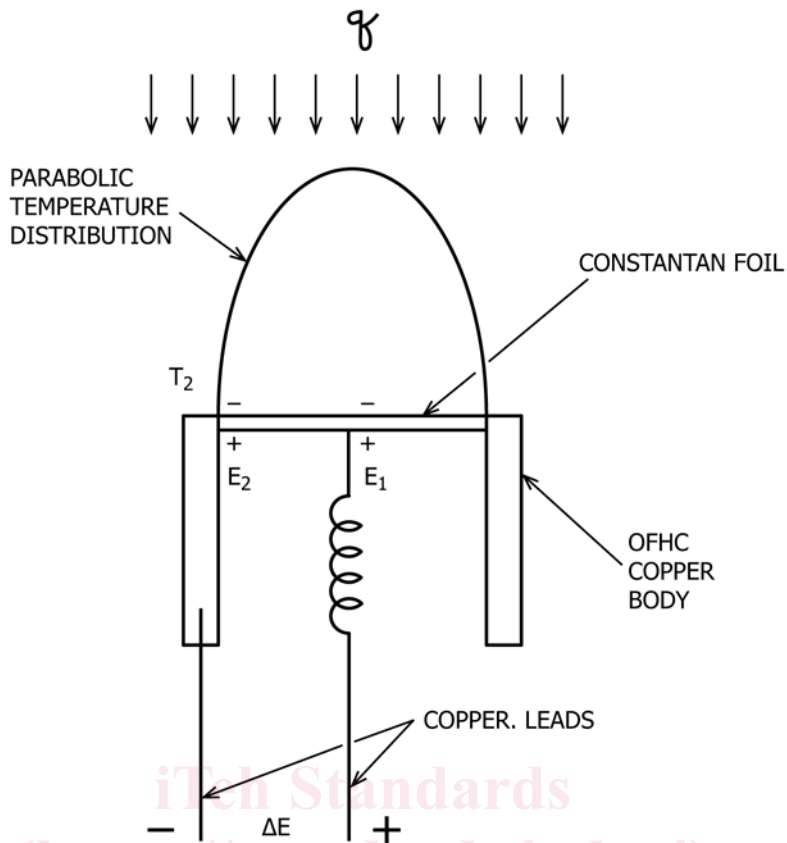

FIG. 1 Heat Drain—Either by Water Cooling the Body with a Surrounding Water Jacket or Conducting the Heat Away with Sufficient Thermal Mass

constantan. Other metal combinations may be employed for use at higher temperatures, but most (4) are nonlinear.

3.3 Because the thermocouple junction at the edge of the foil is the reference for the center thermocouple, no cold junction compensation is required with this instrument. The wire leads used to convey the signal from the transducer to the readout device are normally made of stranded, tinned copper, insulated with TFE-fluorocarbon and shielded with a braid over-wrap that is also TFE-fluorocarbon-covered.

3.4 Transducers with a heat-sink thermocouple can be used to indicate the foil center temperature. Once the edge temperature is known, the temperature difference from the foil edge to its center may be directly read from the copper-constantan (Type T) thermocouple table. This temperature difference then is added to the body temperature, indicating the foil center temperature.

3.5 Water-Cooled Transducer:

3.5.1 A water-cooled transducer should be used in any application where the copper heat-sink would rise above 235 °C (450 °F) without cooling. Examples of cooled transducers are shown in Fig. 2. The coolant flow must be sufficient to prevent local boiling of the coolant inside the transducer body, with its characteristic pulsations (“chugging”) of the exit flow indicating that boiling is occurring. Water-cooled transducers can use brass water tubes and sides for better machinability and mechanical strength.

3.5.2 The water pressure required for a given transducer design and heat-flux level depends on the flow resistance and the shape of the internal passages. Rarely will a transducer require more than a few litres of water per minute. Most require only a fraction of litres per minute.

3.5.3 Heat fluxes in excess of 3400 W/cm² (3000 Btu/ft²/s) may require transducers with thin internal shells for efficient transfer of heat from the foil/heat sink into a high-velocity water channel. Velocities of 15 to 30 m/s (49 to 98 ft/s) are produced by water at 3.4 to 6.9 MPa (500 to 1000 psi). For such thin shells, zirconium-copper may be used for its combination of strength and high thermal conductivity.

NOTE 1—Changing the heat sink from pure copper to zirconium copper may change the sensitivity and the linearity of the response.

3.6 Foil Coating:

3.6.1 High-absorptance coatings are used when radiant energy is to be measured. Ideally, the high-absorptance coating should provide a nearly diffuse absorbing surface, where absorption is independent of the angle of incidence of radiation on the coating. Such a coating is said to be Lambertian and the sensor output is proportional to the cosine of the angle of incidence with respect to normal. An ideal coating also would have no dependency of absorption with wavelength, approximating a gray-body. Only a few coatings approach these ideal characteristics.

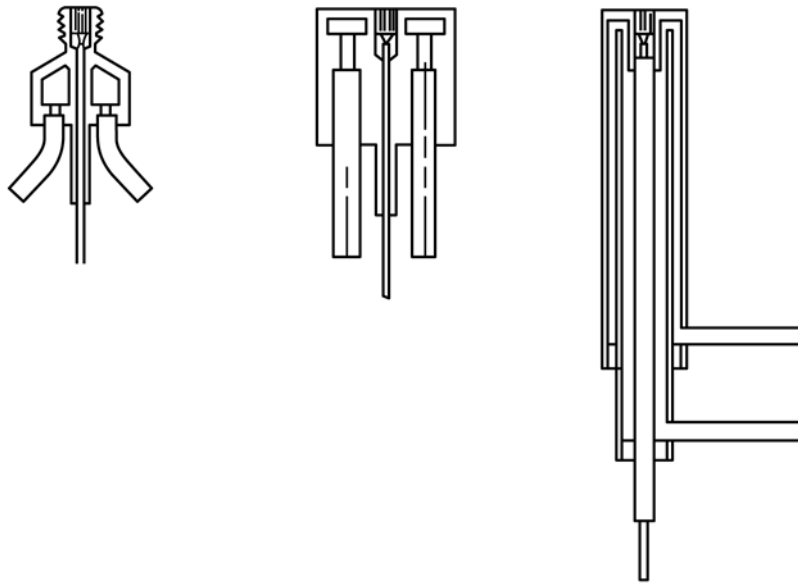

FIG. 2 Cross-Sectional View of Water-Cooled Heat-Flux Gages

3.6.2 Most high absorptivity coatings have different absorptivities when exposed to hemispherically-incident or narrower-angle, incident radiation. For five coatings, measurements by Alpert, et al, showed the near-normal absorptivity was 3 to 5 % higher than the hemispherical absorptivity (5). This work also showed that commercial heat flux gauge coatings generally maintain Lambertian (Cosine Law) behavior out to incidence angles 60° to 70° off-normal.

3.6.3 Acetylene soot (total absorptance $\alpha_T = 0.99$) and camphor soot ($\alpha_T = 0.98$) have the disadvantages (4) of low oxidation resistance and poor adhesion to the transducer surface. Colloidal graphite coatings dried from acetone or alcohol solutions ($\alpha_T = 0.83$) are commonly used because they adhere well to the transducer surface over a wide temperature range. Spray black lacquer paints ($\alpha_T = 0.94$ to 0.98), some of which may require baking, also are used. They are intermediate in oxidation resistance and adhesion between the colloidal graphites and soots. Colloidal graphite is commonly used as a primer for other, higher-absorptance coatings.

3.6.4 Low-absorptance metallic coatings, such as highly polished gold or nickel, may be used to reduce a transducer's response to radiant heat. Because these coatings effectively increase the foil thickness, they reduce the transducer sensitivity. Gold coating also makes the transducer response nonlinear because the thermal conductivity of this metal changes more rapidly with temperature than that of constantan or nickel; the coating must be thin to avoid changing the Seebeck Coefficient.

3.6.5 Exothermic reactions occurring at the foil surface will cause additional heating of the transducer. This effect may be highly dependent on the catalytic properties of the foil surface. Catalysis can be controlled by surface coatings (3).

4. Characteristics and Limitations

4.1 The principal response characteristics of a circular foil heat flux transducer are sensitivity, full-scale range, and the nominal time constant, which are established by the foil

material, diameter and thickness. For a given heat flux, the transducer sensitivity is proportional to the temperature difference between the center and edge of the circular foil. To increase sensitivity, the foil is made thinner or its diameter is increased. The full-scale range of a transducer is limited by the maximum allowed temperature at the center of the foil. The range may be increased by making the foil smaller in diameter, or thicker. An approximate transducer time constant is proportional to the square of the foil radius, and is characterized by (1, 3, 6):

$$\tau \approx \rho c R^2 / 4k \quad (2)$$

where the foil properties and dimensions are:

- τ = radial coordinate,
- ρ = density,
- c = specific heat,
- R = radius, and
- k = conductivity.

4.2 Foil diameters and thicknesses are limited by typical manufacturing constraints. Maximum optimum foil diameter to thickness ratio is 4 to 1 for sensors less than 2.54 mm diameter. Foil diameters range from 25.4 to 0.254 mm, with most gages between 1.02 and 6.35 mm. The time constants, τ , for a 25.4-mm and 0.254-mm diameter foil are 6 s and 0.0006 s, respectively. For constantan, the time constant is approximated by $\tau = 0.0094 d^2$, where d is in mm. The effects of foil dimensions on the nominal time constant are shown in Fig. 3. Keltner and Wildin provide a detailed analysis of the sensitivity and dynamic response that includes the effect of heat transfer down the center wire (7).

4.3 The radiative sensitivity of commercially available transducers is limited to about 2 mV/W/cm² (1.76 BTU/ft²/s). Higher sensitivities can be achieved, but the foils of more sensitive transducers are extremely fragile. The range of commercial transducers may be up to 10 000 W/cm² (~8800 BTU/ft²/s), and typically is limited by the capacity of the heat

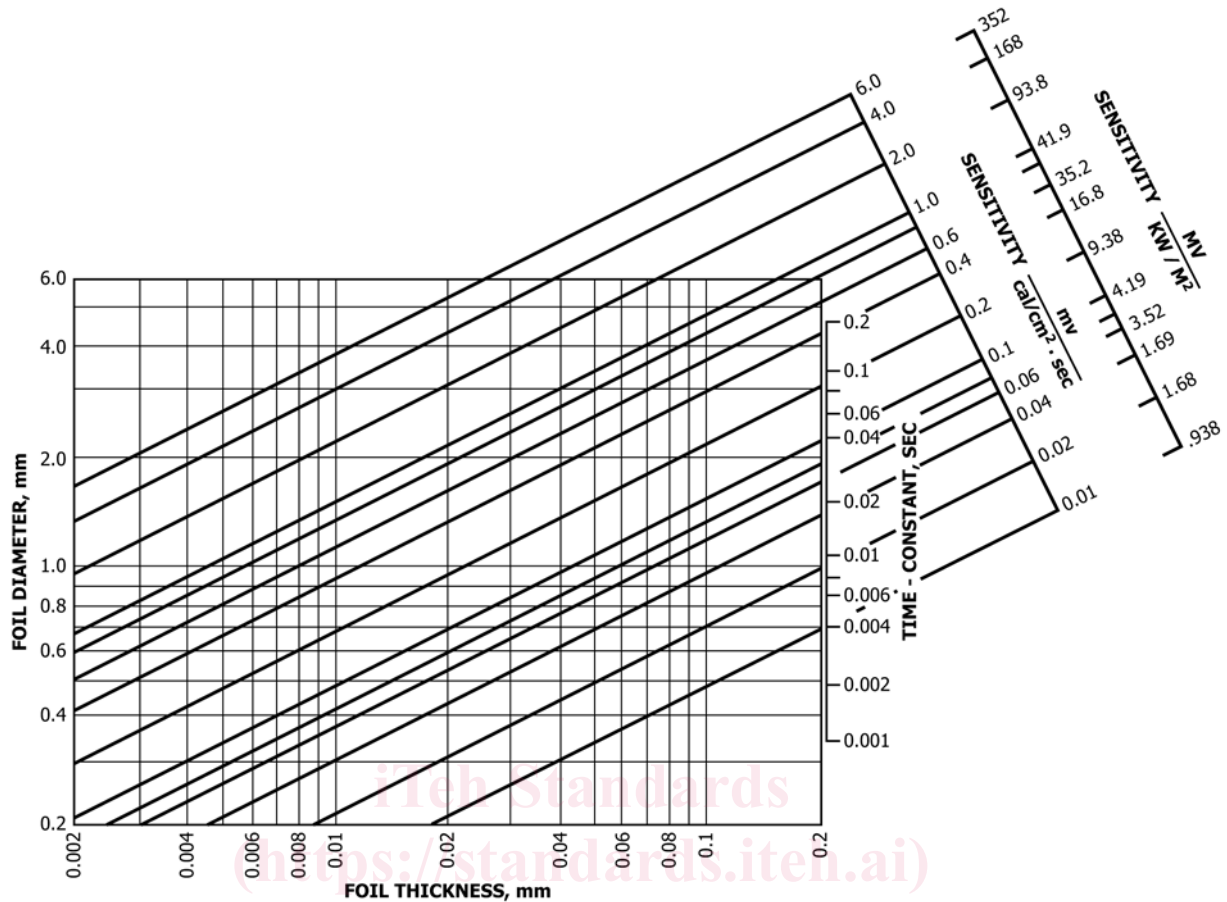

FIG. 3 Chart for Design of Copper-Constantan Circular Foil Heat-Flow Meters (SI Units)

sink for heat removal. The full-scale range is normally specified as that which produces 10 mV of output. This is the potential produced by a copper-constantan transducer with a temperature difference between the foil center and edge of 190 °C (374 °F). These transducers may be used to measure heat fluxes exceeding the full-scale (10 mV output) rating; however, more than 50 % over-ranging will shorten the life and possibly change the transducer characteristics. If a transducer is used beyond 200 % of its full-scale rating, it should be returned to the manufacturer for inspection and recalibration before further use. Care should be taken not to exceed recommended temperature limits to ensure linear response. This is designed for in two ways: active cooling and by providing a heat sink with the copper body. The effects of foil dimensions on the transducer sensitivity are shown in Fig. 4. Refs (7-9) provide more detailed analysis of the sensitivity that includes the effects of heat transfer down the center wire.

4.4 Water-cooled sensors are recommended for any application in which the sensor body would otherwise rise above 235 °C (450 °F). When applying a liquid-cooled transducer in a hot environment, it may be important to insulate the body of the transducer from the surrounding structure if it is also hot.

This will improve the effectiveness of cooling and reduce the required liquid flow rate.

4.5 The temperature of the gage body normally is low in comparison to the heat source. The resulting heat flux measured by the gage is known as a “cold wall” heat flux.

4.6 For measurements of purely radiant heat flux, the transducer output signal is a direct response to the energy absorbed by the foil; the absorptivity of the surface of the coating must be known to correctly calculate the incident radiation flux (5).

4.7 The circular foil transducer cannot be used for conduction heat-flux measurements.

4.8 The circular foil transducer should be used with great care for convective heat-flux measurements because (a) there are no standardized calibration methods; (b) the uncertainty increases rapidly for free-stream temperatures below 1000 °C, although proper range selection can minimize the increase; and, (c) the uncertainty varies with the free-stream velocity vector (10,11). In shear flows, the sensors can display nonlinear response and high uncertainty (12,13).

4.9 Error Sources:

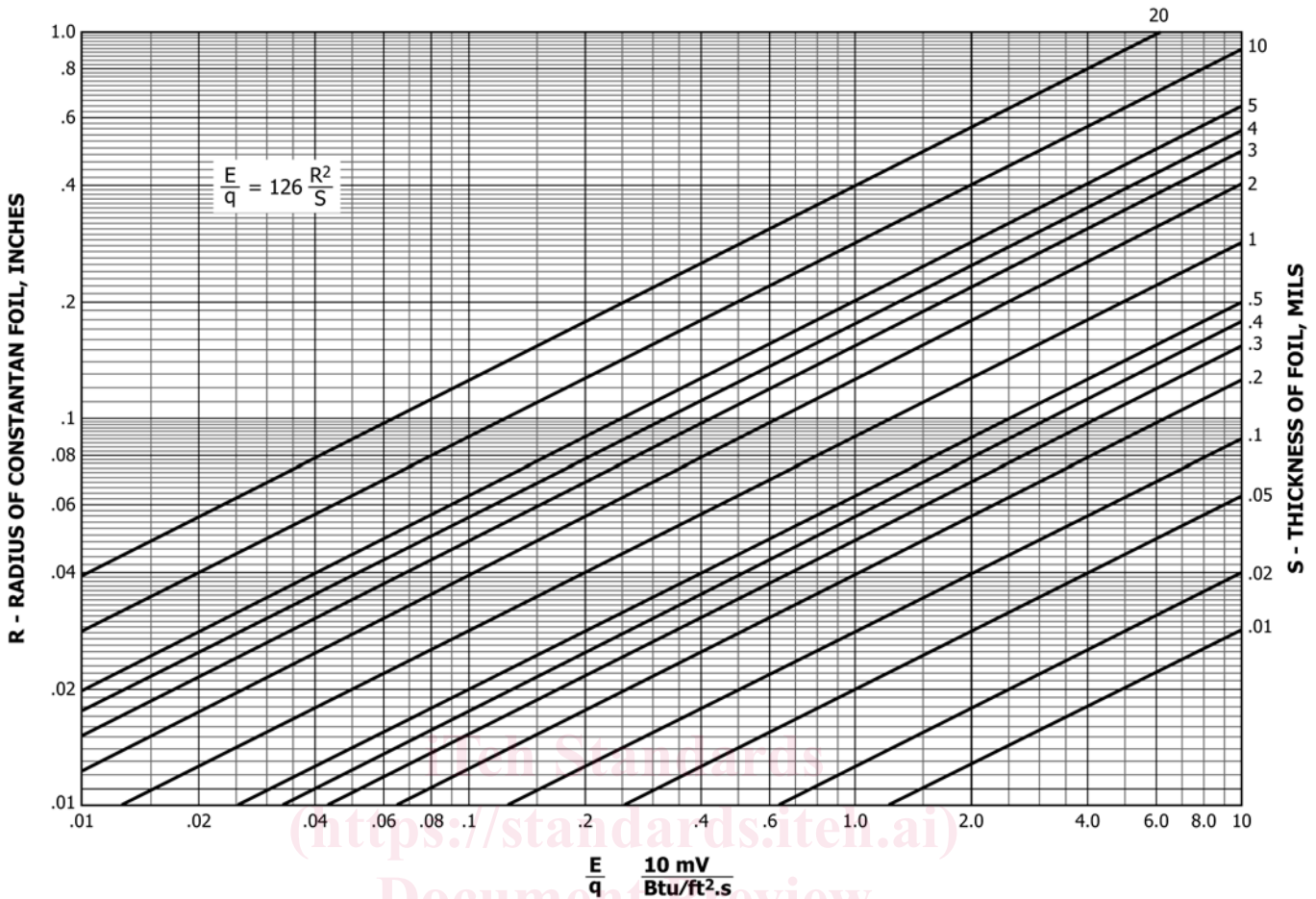

FIG. 4 Chart for Design of Copper-Constantan Circular Foil Heat-Flow Meters (U.S. Customary Units)

4.9.1 *Radiative Heat Transfer*—If there is a uniform incident heat flux over the foil, convective and radiative heat losses from the foil surfaces are negligible, and heat transfer down the center wire is neglected, then the foil temperature distribution is parabolic:

$$T(r) = \frac{q_r}{4k\delta} (R^2 - r^2) \quad (3)$$

where:

- q_r = absorbed radiant heat flux,
- δ = foil thickness,
- R = foil radius, and
- k = foil conductivity.

and the center to edge temperature difference is:

$$\Delta T = \frac{q_r R^2}{4k\delta} \quad (4)$$

4.9.1.1 *Net Radiative Heat Transfer*—For calibrations of transducers at low heat fluxes, the net radiant heat flux varies with radial position on the foil due to reradiation. For a nominal full-scale output of 10 mV, the center-to-edge temperature difference is approximately 150 K. If this foil temperature variation is significant with respect to the source temperature, the uncertainty will increase. For example, if the heat sink temperature is 300 K, reradiation from the center of

the foil (450 K) will be 2 to 2.5 kW/m² while at the edge of the foil it is only 20 % of the center level. For incident blackbody heat fluxes of 50 and 150 kW/m², the blackbody temperatures are approximately 1000 and 1300 K. For these two cases, the net radiant heat flux (absorbed – reradiation) at the center of the foil will be lower than at the edge of the foil by 5 % and 1.5 % respectively (12). The measured transducer output is based on the total net heat transfer to the foil (that is, the integral of the net heat flux from $r = 0$ to R) (6). For the 50 kW/m² case, the total net heat transfer to the foil is 2 to 2.5 % below the absorbed value. Failing to account for this variation between the absorbed and the net heat transfer will increase the measurement uncertainty, especially for incident heat flux calibrations. Proper calibration can reduce these errors.

4.9.1.2 *Vacuum Operation*—A circular foil transducer can be used in a vacuum for radiant heat flux measurements. In general, the back of the gauge should be vented. If maximum accuracy is desired, the transducer should be calibrated in a similar vacuum to minimize differences in convective heat loss off the exposed and unexposed surfaces of the foil. The output of the transducer will be slightly higher in a vacuum because of a small conductive or convective heat flow between the back of

the foil and the body of the transducer when it is used at atmospheric pressure, to a degree that depends on the foil dimensions.

4.9.1.3 *Focused Radiant Energy*—Commercial transducers are generally calibrated with sources that produce an essentially uniform heat flux exposure over the foil area; this produces a parabolic temperature profile across the foil (Fig. 1). If a transducer is used to measure a sharply focused light source, such as a laser beam or imaging optical system, its calibration may not be applicable.

4.9.1.4 *Hemispherical versus Narrow Angle Exposure*—Most coatings have different absorptivities when exposed to hemispherical or near-normal, incident radiation. Measurements by Alpert, et al, showed the near-normal absorptivity was 3 to 5 % higher than the hemispherical absorptivity (5). Use of hemispherically incident radiation for calibration of a transducer for near-normal measurements will introduce an error; the reverse is also true.

4.9.1.5 The field of view of a circular foil transducer used for radiative heat flux measurements is often a hemisphere, or 180°. Transducer sensitivity to a point source of heat flux is greatest at normal incidence, and follows an approximate cosine law out to lower incidence angles (5). Off-normal radiative sensitivity may also be a function of the incident wavelength and the condition of the circular foil surface. Measurements made with a 180° field of view circular foil transducer and another transducer (for example, radiometer) with a more limited field of view are not directly comparable unless the radiant source has uniform intensity over the entire hemisphere.

4.9.2 *Convective Heat Transfer*—The sensitivity to stagnation flow, convective heating is generally lower than the sensitivity to radiative heating (10,14). A method for estimating the sensitivity in stagnation flow or mixed radiative and convective heating is given in Refs (4, 6, and 14). This correction is shown in Annex A1. There are no standardized, convective calibration methods.

4.9.2.1 When the bulk flow is parallel to the sensor surface (a.k.a shear flow) the temperature distribution in the foil becomes asymmetric due to nonuniform heating (11,12,13). The peak temperature moves downstream from the center of the foil and causes the response to become nonlinear. Exercise caution when circular foil transducers are used for measuring convective heat flux in shear flows unless the free stream temperature is high.

4.9.2.2 Unpublished work from Virginia Tech has shown the calibration uncertainties in stagnation flow and shear flow are 2× or more higher than for pure radiation heat sources.

4.9.2.3 *Mixed Radiative and Convective Heat Transfer*—Mixed-Mode offers the same type of challenges as convective measurements due to nonuniform (radially varying) heat transfer to the circular foil and the different sensitivities for radiant and convective heating. As a result, a correction must be made when using a radiant calibration to interpret mixed-mode heat flux measurements. Kuo and Kulkarni (14) demonstrated that this correction is the same as the one shown in Annex A1 for convective heating.

4.9.3 *Calibration Procedures:*

4.9.3.1 While most of the calibration systems for circular foil gauges use radiant heating, there are significant differences in the designs between them. The Building and Fire Research Laboratory at NIST reported on a Round-Robin Calibration Project conducted by the FORUM for International Cooperation in Fire Research. Even though all of the calibration methods in the round-robin were traceable to physical standards, the 95 % confidence interval for this inter-laboratory calibration was $\pm 9.2\%$ (15). Because radiant calibration systems have a long history and are the most common, this section will focus on them.

4.9.3.2 Radiant calibration techniques include blackbody furnaces, dual-cavity systems, graphite plates, quartz lamp arrays, and gas-fired radiant panels. There are techniques using blackbody furnaces, dual-cavity systems, and graphite plates that expose the sensor being calibrated to either hemispherically incident or narrow-angle (incidence angle $< 60^\circ$ off-normal) radiant heating.

4.9.3.3 The method used to determine (standardize) the heat flux exposure generally depends on the design of the heat source. Optical pyrometry is generally used with dual-cavity systems and some blackbody furnaces. Electrically Calibrated Radiometers (ECR) are used at NIST and other laboratories for ex-cavity blackbody calibrations. Transfer Standard Gauges are often used in graphite plate (greybody) and in-cavity calibrations. Each offers different benefits and uncertainties.

4.9.3.4 Murthy, et al (16) and Murthy, et al (17) describe in detail ex-cavity and in-cavity calibration using a dual-cavity source and a sensor which has a high-absorptivity coating only on the circular foil. Because the hemispherical sources fill the field-of-view of the sensor, the source temperature is lower than that of a narrow-angle source for the same incident heat flux. Hemispherical and narrow-angle sources produce different calibration values for the same sensor. This generally results from: (a) differences in the spectral absorptivity as a function of source temperature and hemispherical versus near normal absorptivity of the sensor; and (b) either undefined convective heat transfer when the sensor is inserted into a black-body furnace or dual-cavity source ($\sim 3 \text{ kW/m}^2$ – level reported in Ref (17)) (c) conductive and/or convective heat transfer, when the cooled sensor is in close proximity to a heated graphite plate. Calibration results are usually best when the calibration method is most similar to the application.

4.9.4 *Other Error Sources*—Physical or chemical processes other than heat transfer may affect the accuracy of measurements made with a circular foil heat-flux transducer.

4.9.4.1 If the dew point of the atmosphere at the face of the transducer is above the temperature of any portion of the circular foil, condensation may occur. This will release heat energy, sensed as heat flux, resulting in errors; thus, it is advisable to use a cooling water supply whose temperature is above the dew point of the atmosphere surrounding the transducer. Measurements of heat flux produced by flames in closed chambers are particularly subject to this error if the fuel being burned contains hydrogen.

4.9.4.2 Catalytic processes at the face of the transducer (18) can cause similar errors.

5. Procedure for Selection and Use

5.1 The steps in specifying and employing a circular foil transducer for an intended measurement of heat flux shall be as follows:

5.1.1 The need for water cooling shall be determined from ambient temperature, estimates of the heat-flux level and exposure time for the application. If the ambient temperature is greater than 235 °C (450 °F), a water-cooled unit shall be selected. If the level of heat flux is greater than 5 W/cm² (4.41 BTU/ft²/s) and the duration of exposure is greater than 5 min, a water-cooled unit is likely to be the better choice. If the level of heat flux is less than 5 W/cm², or if the duration of exposure is less than 5 min, a conduction-cooled unit may be chosen. Combinations of ambient temperatures below 235 °C and heat fluxes below 5 W/cm² may require water cooling, depending upon the method of mounting the transducer and the surrounding substrate material (for example, a larger copper heat sink would enhance conduction and reduce the need for water cooling). If there is uncertainty about the level of heat flux or the ambient temperature, a water-cooled unit should be selected.

5.1.2 If the heat source to be measured is purely radiative, the full-scale range for the transducer shall be selected so that the expected maximum heat flux does not exceed the range by more than 50 %.

5.1.2.1 Matching the type of calibration (hemispherical or narrow-angle incidence) to the application will produce the best results.

5.1.2.2 If a window is used to suppress convective heat transfer and create a radiometer, the transducer should be calibrated with the window in place at multiple points up to the full-scale range; at full-scale, the radiant source temperature should approximate the temperature of the intended operation. The spectral transmission range of windows depends on the window material and typically varies with optical wavelength (12). As a result, errors can occur when the spectral distribution of the radiant energy varies with time because the application temperature changes, such as in some furnaces (19).

5.1.2.3 Radiometers without windows can be created by slight restrictions in the transducer field-of-view, gas purging, or a combination of the two.

5.1.3 If the heat source to be measured is purely convective, the full-scale range for the transducer should be no less than 20 times the expected maximum heat flux.

5.1.4 If the heat source to be measured is mixed radiative and convective, the full-scale range for the transducer should be no less than 20 times the expected maximum convective portion.

5.1.5 In selecting a mounting method for the transducer, the thermal grounding procedures for water-cooled and conduction-cooled units are very different. Water-cooled transducers, particularly those used in an elevated-temperature environment, should be thermally insulated from the surroundings. This will reduce the required cooling water flow to a minimum. Conduction-cooled transducers should be thermally grounded, with minimum resistance to the surrounding cool structure.

5.1.6 The transducer mounting shall protect the signal wiring against abrasion, excessive flexing, and temperature extremes.

5.1.7 The circular foil of the transducer shall be protected from fingerprints, abrasion, or contact with any sharp object during installation and use.

5.1.8 For water-cooled units, an adequate source of cooling water shall be provided, with temperature above the dew point of the transducer environment. Interlocks are recommended to prevent exposure of the transducer to heat flux unless the cooling water is circulating.

5.1.9 The signal leads of the transducer shall be connected, preferably with shielded, twisted pair, to a potentiometric recorder or high-input impedance amplifier of accurately known amplification factor. If a thermocouple is included in the transducer, it shall be connected using leads of the same thermocouple materials to a cold junction circuit that will compensate for ambient temperature.

5.1.10 The circular foil shall be inspected before and after measurements to insure that no damage has occurred to the foil and there has been no degradation of the coating, if applied.

5.1.11 If the transducer is a water-cooled unit, the water shall be turned on before the source of heat flux is turned on, and turned off after the transducer has cooled down.

5.2 Calculation:

5.2.1 The radiant heat flux shall be calculated using the equation:

$$q' = E/K \quad (5)$$

where the factors E , K , and q' are all in the units used in the manufacturer's specification sheet.

5.2.2 If the heating is mixed-mode, correct the radiant calibration as shown in Annex A1.

5.2.3 If the transducer is other than a copper-constantan unit, consult the manufacturer's tables supplied with the unit for temperature corrections.

5.3 Report:

5.3.1 Test results shall include a record of the serial number and sensitivity of the transducer, a graph of the output of the transducer as a function of time if a recorder is used, or the discrete values and times they were measured if a continuous recording was not made. If a thermocouple is included in the transducer, its indications shall be recorded in the same manner. The report also shall include a list of the other instruments used, a drawing or description of the experimental arrangement, and a record of conditions that might affect the accuracy of the data. An estimate of the uncertainty of the heat-flux data, and how the estimate is made, must be included in the report.

6. Precision and Bias

6.1 There is no established statement on the precision and bias for heat-flux measurements made with circular foil heat-flux transducers. As noted below, work on defining calibration and application uncertainty is ongoing. A survey of the participants at the First NIST/NSF Workshop on Heat Flux Transducer Calibration (15) agreed that ± 3 % of full scale was a good estimate of the calibration uncertainty in the gauge