



Designation: G199 – 09 (Reapproved 2020)<sup>ε1</sup>

## Standard Guide for Electrochemical Noise Measurement<sup>1</sup>

This standard is issued under the fixed designation G199; the number immediately following the designation indicates the year of original adoption or, in the case of revision, the year of last revision. A number in parentheses indicates the year of last reapproval. A superscript epsilon ( $\epsilon$ ) indicates an editorial change since the last revision or reapproval.

<sup>ε1</sup> NOTE—Replaced Terminology G15 with Terminology G193, and other editorial changes made throughout in Dec. 2020.

### 1. Scope

1.1 This guide covers the procedure for conducting online corrosion monitoring of metals by the use of the electrochemical noise technique. Within the limitations described, this technique can be used to detect localized corrosion activity and to estimate corrosion rate on a continuous basis without removal of the monitoring probes from the plant or experimental cell.

1.2 This guide presents briefly some generally accepted methods of analyses that are useful in the interpretation of corrosion test results.

1.3 This guide does not cover detailed calculations and methods; rather it covers a range of approaches that have found application in corrosion testing.

1.4 The values stated in SI units are to be regarded as standard. No other units of measurement are included in this standard.

1.5 *This standard does not purport to address all of the safety concerns, if any, associated with its use. It is the responsibility of the user of this standard to establish appropriate safety, health, and environmental practices and determine the applicability of regulatory limitations prior to use.*

1.6 *This international standard was developed in accordance with internationally recognized principles on standardization established in the Decision on Principles for the Development of International Standards, Guides and Recommendations issued by the World Trade Organization Technical Barriers to Trade (TBT) Committee.*

### 2. Referenced Documents

#### 2.1 ASTM Standards:<sup>2</sup>

<sup>1</sup> This guide is under the jurisdiction of ASTM Committee G01 on Corrosion of Metals and is the direct responsibility of Subcommittee G01.11 on Electrochemical Measurements in Corrosion Testing.

Current edition approved Nov. 1, 2020. Published December 2020. Originally approved in 2009. Last previous edition approved in 2014 as G199 – 09 (2014). DOI: 10.1520/G0199-09R20E01.

<sup>2</sup> For referenced ASTM standards, visit the ASTM website, [www.astm.org](http://www.astm.org), or contact ASTM Customer Service at [service@astm.org](mailto:service@astm.org). For *Annual Book of ASTM Standards* volume information, refer to the standard's Document Summary page on the ASTM website.

- G1 Practice for Preparing, Cleaning, and Evaluating Corrosion Test Specimens
- G3 Practice for Conventions Applicable to Electrochemical Measurements in Corrosion Testing
- G4 Guide for Conducting Corrosion Tests in Field Applications
- G5 Reference Test Method for Making Potentiodynamic Anodic Polarization Measurements
- G16 Guide for Applying Statistics to Analysis of Corrosion Data
- G31 Guide for Laboratory Immersion Corrosion Testing of Metals
- G46 Guide for Examination and Evaluation of Pitting Corrosion
- G59 Test Method for Conducting Potentiodynamic Polarization Resistance Measurements
- G61 Test Method for Conducting Cyclic Potentiodynamic Polarization Measurements for Localized Corrosion Susceptibility of Iron-, Nickel-, or Cobalt-Based Alloys
- G96 Guide for Online Monitoring of Corrosion in Plant Equipment (Electrical and Electrochemical Methods)
- G102 Practice for Calculation of Corrosion Rates and Related Information from Electrochemical Measurements
- G106 Practice for Verification of Algorithm and Equipment for Electrochemical Impedance Measurements
- G193 Terminology and Acronyms Relating to Corrosion

### 3. Terminology

3.1 *Definitions*—The terminology used herein, if not specifically defined otherwise, shall be in accordance with Terminology G193. Definitions provided herein and not given in Terminology G193 are limited only to this guide.

#### 3.2 *Definitions of Terms Specific to This Standard:*

3.2.1 *coupling current, n*—measured current flowing between two electrodes in an electrolyte coupled by an external circuit.

3.2.2 *current measuring device, n*—device that is capable of measuring the current flow across the electrode/electrolyte interface or the coupling current of a pair of electrodes, usually a zero resistance ammeter (ZRA) or current-to-voltage converter.

3.2.3 *electrochemical current noise measurement*, *n*—electrochemical noise measurement using an electrochemical current signal.

3.2.4 *electrochemical noise measurement (ENM)*, *n*—technique involving the acquisition and analysis of electrochemical current and potential signals.

3.2.5 *electrochemical potential noise measurement*, *n*—electrochemical noise measurement using an electrochemical potential signal.

3.2.6 *Fourier transform*, *n*—transformation of a time domain signal into the frequency domain.

3.2.7 *galvanostat*, *n*—device used for automatically maintaining a controlled current between two electrodes.

3.2.8 *noise impedance*,  $|Z_n|$ ,  $[\Omega]$ , *n*—ratio of the amplitude of potential noise to current noise, in the frequency domain, at a specified frequency.

3.2.9 *noise resistance*,  $R_n$ ,  $[\Omega]$ , *n*—standard deviation of potential noise divided by the standard deviation of current noise.

3.2.10 *pit indicator*, *n*—standard deviation of current noise divided by the mean of the coupling current.

3.2.11 *pitting factor*, *n*—standard deviation of the current noise divided by the general corrosion current.

3.2.11.1 *Discussion*—The general corrosion current is normally estimated by a secondary electrochemical means.

3.2.12 *pitting index*, *n*—standard deviation of current noise divided by the root mean square of the coupling current calculated over the same sample period.

3.2.13 *potential measuring device*, *n*—a high impedance digital voltmeter or electrometer used to measure the potential between two electrodes.

3.2.13.1 *Discussion*—Ideally, one of these electrodes is under study and the other is a reference electrode; however, the measurements may be made between two nominally identical electrodes manufactured from the material being studied.

3.2.14 *potentiostat*, *n*—device used for automatically maintaining a controlled voltage difference between an electrode under study and a reference electrode in which a third electrode, the counter (or auxiliary) electrode, is used to supply a current path from the electrode under study back to the potentiostat.

3.2.15 *sample interval*, *n*—time delay between successive electrochemical noise measurements.

3.2.16 *sample period*, *n*—time between the first and last data collection during electrochemical noise measurement.

3.2.17 *time domain analysis*, *n*—direct evaluation of time series data, for example, using statistical descriptions of the data.

3.2.18 *time record*, *n*—dataset obtained over a sample period at a typical sample interval in electrochemical noise measurement.

3.2.19 *zero resistance ammeter (ZRA)*, *n*—electronic device used to measure current without imposing a significant IR drop by maintaining close to 0-V potential difference between the inputs.

## 4. Summary of Guide

4.1 Electrochemical noise measurement is used for monitoring of localized corrosion processes such as pitting (1, 2).<sup>3</sup>

4.2 Electrochemical noise measurement may be used to estimate a general corrosion rate (3).

4.3 Electrochemical noise measurement operates on the principle that fluctuations in potential and current occur as a result of spontaneous changes in the instantaneous corrosion rate (4). The fluctuations may be due to one or more of several phenomena that include: initiation (5) and propagation of localized corrosion (6), Faradaic currents (7), double-layer capacitance discharge, gas bubble formation (8), adsorption/desorption processes, surface coverage (9), diffusion (10), variation of film thickness (11), mobility of charge carrier (12), passivity breakdown (13), and temperature variations (14, 15).

4.4 The noise fluctuations associated with corrosion phenomena can usually be distinguished from thermal (white) noise (caused by thermal effects in which noise power is directly proportional to the measured bandwidth), Johnson noise (produced by the measurement instrumentation), and shot noise (in electrical circuits caused by the quantized nature of the electronic charge) (16-18). However, the electrochemical noise signals generated may have characteristics similar to those stated in the preceding sentence.

4.5 The electrochemical noise method of corrosion measurement may help to evaluate the corrosion mechanism of metals in electrolytes. Its particular advantage is in continuous monitoring without applying any external perturbation.

4.6 *Method A—ZRA-Based Current and Potential Measurement*—Two nominally identical electrodes are coupled through a ZRA, which maintains a 0-V potential difference between them by injecting (measured) current. The potential between the couple and a third (reference) electrode is also measured. The reference electrode may be either a conventional reference electrode such as a saturated calomel electrode (SCE) or simply be a third electrode identical in material to the coupled electrodes (19, 20).

4.7 *Method B—Potentiostatic Current Measurement with Standard Reference Electrode*—Reference Test Method G5 provides practice for making potentiostatic measurements. The working electrode potential is controlled with respect to the reference electrode at a prescribed value. The current measured (flowing between the working (Test 1) and auxiliary or counter (Test 2) electrodes) is that required to maintain potential control (21, 22).

NOTE 1—Noise on the reference electrode will result in a corresponding current noise signal; therefore, the reference electrode needs to be relatively noise free. The potential measurement can only be made across the auxiliary and working electrodes, as the potential between the reference and the working is held constant by the potentiostat. The voltage developed across the auxiliary and working electrodes is a function of the current flowing through the cell and the impedance caused by the auxiliary electrode, the working electrode, and the solution resistance.

<sup>3</sup> The boldface numbers in parentheses refer to the list of references at the end of this standard.

4.8 *Method C—Galvanostatic Potential Measurement*—An electrode is supplied with current from a galvanostat at a prescribed current value. The potential difference between the electrode and a reference electrode is measured. An auxiliary electrode is used to carry the return current.

4.9 There are several methods by which the electrochemical noise data can be obtained (23-26) and analyzed, and some methods of interpreting the data are given in Appendix X1 (27-35). These analyses are included to aid the individual in understanding the electrochemical noise technique and some of its capabilities. The information is not intended to be all-inclusive.

## 5. Significance and Use

5.1 Use of this guide is intended to provide information on electrochemical noise to monitor corrosion on a continuous basis.

5.2 This guide is intended for conducting electrochemical noise measurements, both in the laboratory and in-service environments (36).

5.3 This technique is useful in systems in which process upsets or other problems can create corrosive conditions. An early warning of corrosive attack can permit remedial action before significant damage occurs to process equipment (37).

5.4 This technique is also useful when inhibitor additions are used to control the corrosion of equipment. The indication of increasing corrosion activity can be used to signal the need for additional inhibitor (38).

5.5 Control of corrosion in process equipment requires knowledge of the rate or mechanism of attack on an ongoing basis. This technique can be used to provide such information in a digital format that is easily transferred to computers for analysis (39).

## 6. Limitations and Interferences

6.1 Results are representative of the probe element (electrode). When first introduced into a system, corrosion rates on a probe element may be different from that of the structure.

6.2 Noise can originate from thermal, electrical, and mechanical factors. Since the interest is only on the noise from Faradaic processes, care should be exercised to minimize noise from other sources.

6.3 Probe elements by their nature are consumable. Hazardous situations may occur if probes are left in service for extended periods beyond their probe life. In some configurations, crevice corrosion can cause damage or leaks at the interface between the element and its sealing surface that can cause false readings.

6.4 Electrical contact between probe elements should be avoided. In certain situations (for example, sour corrosion in the presence of hydrogen sulfide), the corrosion products can lead to apparent electrical shorting of the probe elements leading to erroneous readings.

## 7. Apparatus

### 7.1 Electronics:

7.1.1 The input impedance of the device should be high enough to minimize current drawn from the electrodes, such that the electrodes are not polarized by the measuring device. Practice G106 provides guidelines for verification of algorithm and equipment for electrochemical impedance measurements.

7.1.2 The potential range of the device depends on the maximum potential difference between the two electrodes (typically <1 V).

7.1.3 The potential resolution of the device should be adequate to discriminate the signal to within the required accuracy (typically 10  $\mu$ V or lower).

7.1.4 The device should be capable of maintaining an offset potential between the two electrodes of less than 1 mV.

7.1.5 The frequency response of the device should be flat (within the desired accuracy) across the frequency range of the analysis. The device should have a fast enough response so that signal transients are not distorted. Note that the signal that one is attempting to measure may be below the resolution of the instrument.

NOTE 2—The offset voltage will appear as a current offset in the measurement with no electrodes connected.

7.1.6 The current range depends on the system being measured. The wide dynamic ranges seen in passive-to-active transitions (nA to mA) may require auto-ranging circuits.

7.1.7 The bias current of the device should be within the required accuracy of the measurement. Otherwise it may cause an error in the measured current.

7.1.8 The background noise of the device should be below the electrochemical current or potential noise being measured. High-impedance reference electrode inputs may pick up extraneous noise from the environment and shielding may be required. An independent measurement of the background noise level should be performed.

7.1.9 The requirements in 7.1.1 – 7.1.8 do not include all possible combinations of instrumentation and electrode arrangements. The instrument, cell, and analysis requirements should be determined by the particular test being undertaken.

7.2 *Test Cell*—The test cell should be constructed to allow the following items to be inserted into the solution chamber:

7.2.1 Three identical electrodes, two of which comprise the coupled electrodes and the third electrode acts as a reference. Alternatively, instead of the third identical electrode, a Luggin-Haber capillary with salt bridge connection for a reference electrode may be used.

7.2.2 An inlet and an outlet for air or an inert gas.

7.2.3 A thermometer or thermocouple holder.

7.2.4 The test cell shall be constructed from materials that will not corrode, deteriorate, or otherwise contaminate the solution. Guide G31 provides standard practice for conducting immersion corrosion testing.

7.2.5 One type of suitable cell is described in Reference Test Method G5. Cells are not limited to that design. For example, a 1 L round-bottom flask can be modified for the addition of various necks to permit the introduction of electrodes, gas inlet and outlet tubes, and the thermometer holder. A Luggin-Haber capillary probe could be used to separate the bulk solution from the reference electrode. The capillary tip can be adjusted to

bring it into close proximity to the working electrode. The minimum distance should be no less than two capillary diameters from the working electrode.

**7.3 Electrode Holder**—The auxiliary and working electrodes can be mounted in the manner shown in Reference Test Method **G5**. Assembly precautions described in Reference Test Method **G5** should be followed.

**7.4 Potentiostat**—The potentiostat shall be of the type that allows application of a potential sweep as described in Reference Test Method **G5** and Test Method **G59**. The potentiostat shall have outputs in the form of voltage versus ground for both potential and current.

**7.5 Collection and Analysis of Current-Voltage Response**—The potential and current measuring circuits shall have the characteristics described in Reference Test Method **G5**.

#### 7.6 Electrodes:

**7.6.1** Electrode preparation should follow Reference Test Method **G5**, which involves drilling and tapping the specimen(s) and mounting on the electrode holder. The working electrode or working electrode pair should be constructed from the material to be tested. If a pair, the electrodes should be prepared from the same piece of strip or rod. If a three “identical” electrode arrangement is to be used, the electrodes should be prepared from the same piece of strip or rod. The electrode surface area should be chosen such that the current measurement will neither saturate (electrodes too large) nor be at the limits of resolution of the current measurement (too small). A good starting point is 10 cm<sup>2</sup>; adjustments are: smaller electrodes for large currents and larger electrodes for small currents. Care should be taken in mounting the electrode(s) to avoid the likelihood of crevice corrosion.

**7.6.2** Reference electrode type and usage should follow Reference Test Method **G5**. A low-impedance, low-noise reference electrode is recommended. The reference and bridge shall not contaminate the electrolyte and shall be suitable for a given combination of alloy and electrolyte. The most appropriate reference electrode and bridge for a given environment will vary. If a reference electrode of the same material as the working electrode(s) is adopted, the user should be aware that the noise characteristics of the reference electrode will be similar to the working electrode(s).

**NOTE 3**—A low-impedance reference electrode is recommended because high-impedance reference electrodes tend to be more susceptible to electrostatic pickup. It is desirable to minimize the bias caused by such environmental noise. Instrument grounding and isolation may also bias measurements in such three-electrode systems.

**7.6.2.1** A conductive bridge between reference and working electrodes may contribute to the intrinsic noise of the measuring system. The use of a high-impedance reference electrode junction is not recommended because of noise (50 to 60 Hz) pickup associated with such high-impedance apparatus. However, a conductive bridge between the electrolyte and reference electrode may be used successfully. A capillary-type Luggin probe is recommended above one with a semipermeable membrane or porous frit.

**7.6.2.2** The potential of a reference electrode should be checked at periodic intervals to ensure the accuracy of the electrode. For other alloy-electrolyte combinations, a different reference electrode may be preferred to avoid contamination of the reference electrode or the electrolyte.

**7.6.2.3** Any reference electrode may be used instead of a standard reference electrode. The reference electrode should ideally have noise characteristics that are less than the magnitude of the potential noise signal that is to be measured. Noble metal electrodes (for example, platinum or gold) are generally unsuitable because of their high-impedance characteristics.

**NOTE 4**—A saturated silver/silver chloride electrode with a controlled rate of leakage (about 3 μL/h) has been found to be suitable. It is durable, reliable, and commercially available. Precautions shall be taken to ensure that the electrode is maintained in the proper condition.

**7.7 Recording Device**—The potential and current signals are recorded continuously using a personal computer (PC) or a digital data recorder. In the former case, either a combination of current and potential measuring instruments or a scanning potentiostat should be interfaced with the PC. The PC should be equipped with appropriate hardware and software to collect and analyze data from the peripheral instruments. The storage requirements for some electrochemical noise data may be substantial and should be considered.

#### 7.8 Signal Transformation and Recording:

**7.8.1** The electrochemical signals are usually sampled in the time domain using analog-to-digital conversion techniques. The sampling rate has a direct bearing on the resolution of the analog-to-digital conversion. Sampling frequency is typically once per second, but faster or slower conversions may be appropriate.

**7.8.2** Analog-to-digital conversion also entails a sampling resolution error. Analog-to-digital converters have finite resolution that, in turn, results in a round-off error that is mathematically equivalent to noise. They may also contribute to the noise over and above this error caused by non-idealities in the converter.

**7.8.2.1** The process of converting from continuous to discrete time signals causes another form of error known as aliasing. When a high-frequency component ( $f \geq f_s/2$ ) is present in the continuous signal, the process of sampling will cause that component to appear at lower frequencies. This limit,  $f_s/2$ , is known as the Nyquist limit. Once a component has been aliased into a lower frequency, it is impossible to differentiate between it and the component originally at that frequency. To overcome this problem, the continuous signal should be filtered with an anti-aliasing filter (for example, low-pass filter) designed to attenuate components significantly at or above the Nyquist limit. This high-frequency component is unlikely to be associated with the electrochemical processes being measured.

**7.8.2.2** Some types of filters, particularly those with very sharp cutoffs, will cause distortion of the signal. If the subsequent analysis depends on the validity of that shape, for example, higher order moment calculations or peak detection, the filter form shall be chosen such that distortion is within the required limits.

## 8. Experimental Procedure

### 8.1 Evaluation and Qualification of Instrumentation:

8.1.1 The measurement instrumentation should be characterized for background noise levels and signal fidelity, for example, by using an open circuit test to assess ZRA offset voltage and background (including meter quantization effects), current noise, and by shorting potential measurement inputs to check instrument zero and injecting a known current into the ZRA to check range selection (40).

8.1.2 A test or dummy cell may be constructed to evaluate the instrumentation and analysis algorithms being used. Fig. 2 shows a test cell that could be used to simulate effects similar to those observed with general corrosion as a result of the passive elements incorporated.

8.2 This circuit and the tests described hereafter are suitable for the ZRA and potentiostatic methods. A similar set of tests should be devised for the galvanostatic method.

8.2.1 The values of double layer capacitance ( $C_{dl}$ ), Faradaic impedance ( $R_f$ ), and uncompensated solution resistance ( $R_u$ ) should be chosen to mimic the corrosion process being studied (41).

8.2.2 A value of reference electrode resistance ( $R_{ref}$ ) should be chosen to match the reference electrode impedance. This is important since the noise pickup of the instrument will depend strongly on  $R_{ref}$ .

8.2.3 If one of the working electrodes is physically grounded, it should be similarly grounded in the test cell. This will necessitate both an electrically isolated measuring circuit and an isolated signal generator.

8.2.4 The physical environment, for example, shielding and extraneous noise, should also represent the actual environment.

8.2.5 A signal source is used to provide a known signal. This may be white noise or a low-distortion, low-amplitude sine wave, or a short circuit depending on the test being performed. The sine wave source should have known amplitude and frequency within  $\sim 0.1\%$ , and harmonic distortion should be below  $\sim 0.1\%$ . The white noise source should have a known root-mean-square (RMS) voltage within  $0.1\%$ . The actual frequencies and amplitudes should mimic the size of the electrochemical signals being measured.

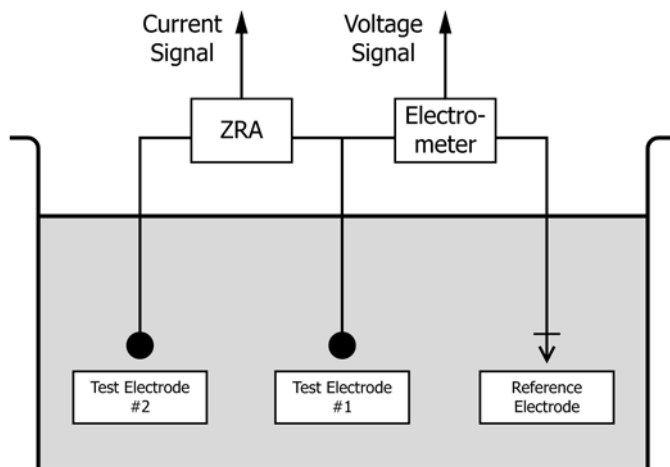

FIG. 1 ZRA-Based Measurement

8.3 *Intrinsic Noise Calibration Procedure*—In this test, the instrumental sensitivity and direct current (dc) offset will be determined.

8.3.1 Connect the measuring instruments to the test cell.

8.3.2 Remove the signal source and replace it with a shorting wire.

8.3.3 Set the measuring instruments' sensitivities and speeds (if applicable) to those required for the electrochemical signal being measured.

8.3.4 Measure current and voltage signals for at least twice as long as the period of the lowest frequency of interest. Use a sample rate ( $f_s$ ) at least twice the highest frequency of interest.

8.3.5 Plot the Fourier transform of current and voltage. This represents a lower bound on the measurable noise from electrochemical processes.

8.3.6 Calculate the RMS, population deviation, and mean values of the background signal. The first two represent measurement uncertainties caused by instrumental limits. The last represents the dc offset present in the instrument.

## 9. Probe Preparation

9.1 Commercial probe elements are generally received in sealed plastic bags to protect prepared surfaces. Care should be taken during installation to avoid handling the probe measurement element, as this may lead to unwanted additional corrosion.

9.2 Probe measurement element surfaces should be smooth and free of indentations or signs of mechanical damage. Grit blasting with 120 grit is suitable as a surface preparation before degreasing.

9.3 If probes are being moved from one system to another, they shall be cleaned mechanically before reuse to ensure complete removal of oxide or inhibitor films. Degreasing is necessary to complete the cleaning procedure. Practice G1 provides guidance on proper methods of cleaning various materials. Some people do not recommend reusing the probe elements.

9.4 Mechanical or chemical cleaning will remove metal from the probe measurement element and may alter its reading.

## 10. Probe Installation

10.1 Install the probe in a position as representative of the corrosive environment as possible without causing deleterious effects to the probe or the system. Probes with protruding elements should not be mounted transversely in a high-flow pipe line without shielding because of the possibility of the electrodes being sheared off. Probes should not be installed in a location where physical or chemical conditions are not representative of the system under examination. Guide G96 provides guidelines for on-line monitoring of corrosion in plant equipment.

## 11. Procedure

11.1 Practice G3 provides guidance for conventions applicable to electrochemical measurements in corrosion testing.

11.2 Instruments are available in various single- or multi-channel configurations. They may be stand-alone systems or