



Designation: F482 – 09 (Reapproved 2020)

Standard Practice for Corrosion of Aircraft Metals by Total Immersion in Maintenance Chemicals¹

This standard is issued under the fixed designation F482; the number immediately following the designation indicates the year of original adoption or, in the case of revision, the year of last revision. A number in parentheses indicates the year of last reapproval. A superscript epsilon (ϵ) indicates an editorial change since the last revision or reapproval.

1. Scope

1.1 This practice covers the determination of the corrosiveness of tank-type aircraft maintenance chemicals on aircraft metals and the corrodibility of metals in these maintenance chemicals with time. The determination is made under conditions of total immersion by a combination of weight change measurements and visual qualitative determinations of change.

1.2 The values stated in SI units are to be regarded as the standard. The values given in parentheses are for information only.

1.3 *This standard does not purport to address all of the safety concerns, if any, associated with its use. It is the responsibility of the user of this standard to establish appropriate safety, health, and environmental practices and determine the applicability of regulatory limitations prior to use. For specific precautions, see Section 6.*

1.4 *This international standard was developed in accordance with internationally recognized principles on standardization established in the Decision on Principles for the Development of International Standards, Guides and Recommendations issued by the World Trade Organization Technical Barriers to Trade (TBT) Committee.*

2. Referenced Documents

2.1 *ASTM Standards:*²

- D235 Specification for Mineral Spirits (Petroleum Spirits) (Hydrocarbon Dry Cleaning Solvent)
- D329 Specification for Acetone
- D1193 Specification for Reagent Water
- E1 Specification for ASTM Liquid-in-Glass Thermometers

¹ This practice is under the jurisdiction of ASTM Committee F07 on Aerospace and Aircraft and is the direct responsibility of Subcommittee F07.07 on Qualification Testing of Aircraft Cleaning Materials.

Current edition approved Nov. 1, 2020. Published December 2020. Originally published in 1977. Last previous edition approved in 2014 as F482 – 09(2014). DOI: 10.1520/F0482-09R20.

² For referenced ASTM standards, visit the ASTM website, www.astm.org, or contact ASTM Customer Service at service@astm.org. For *Annual Book of ASTM Standards* volume information, refer to the standard's Document Summary page on the ASTM website.

3. Significance and Use

3.1 This practice not only provides information on the accumulated effects of corrosion at specific time periods under a given set of conditions, but also provides information on the initial rate of corrosion of virgin metal, the corrosion rate of metal per unit time after long exposure, and the initial corrosion rate of virgin metal after long exposure of the corroding fluid to metal. The test also provides a means of determining the direction corrosion will take with time, although causes for increase or decrease in the corrosiveness and corrodibility of media and metal (such as passive film formation or destruction, depletion of corrosive contaminate, and so forth) as a function of time are not given.

4. Apparatus

4.1 *Wide-Mouth Glass Jar or Flask* of suitable sizes (3000 to 4000 mL), capable of accommodating a reflux condenser, a thermometer, and a specimen support system. Fig. 1 shows a typical arrangement, but any array meeting the provisions of 4.2 – 4.5 is acceptable.

4.1.1 If agitation is required, use an apparatus capable of accepting a stirring mechanism, such as a magnetic stirrer or impeller. Choose the glass jar or flask such that the specimens will remain fully immersed in a vertical position during the test, and the ratio of area of immersed metal to volume of solution will be in accordance with 9.1.

4.2 *Specimen-Supporting Device*—a glass or fluorocarbon plastic supporting system designed to keep the specimen fully immersed while assuring free contact with the corroding solution, and designed to physically isolate the specimens from each other.

4.3 *Condenser*—a glass reflux condenser of the water-cooled type, having a condenser jacket 200 to 300 mm in length.

4.4 *Constant-Temperature Device*—Use any suitable regulated heating device (mantle, hot plate, or bath) to maintain the solution at the required temperature.

4.5 *Thermometer*—an ASTM 75-mm (3-in.) immersion thermometer having a range from –18 to 150 °C (0 to 302 °F) and conforming to requirements for Thermometer 1F in accordance with Specification E1.

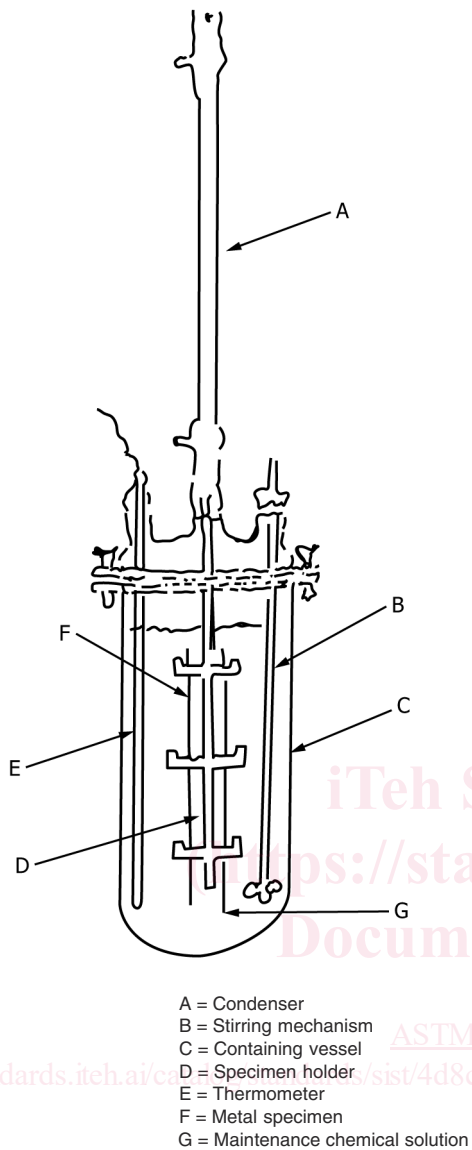

NOTE 1—THIS IS ONE FORM THAT THE EQUIPMENT CAN TAKE, AND IS NOT MANDATORY. ANY ARRAY MEETING THE REQUIREMENTS OF 4.2 – 4.5 IS ACCEPTABLE.

FIG. 1 Test Apparatus

5. Reagents and Materials

5.1 *Mineral Spirits (Petroleum Spirits) (Hydrocarbon Dry Cleaning Solvent*, conforming to Specification D235.

5.2 *Methyl n-propyl ketone (MPK)*.³

5.3 *Acetone*, conforming to Specification D329.

5.4 *Reagent Water*, conforming to Specification D1193.

6. Safety Precautions

6.1 The solvents used in the cleaning of test specimens are flammable and harmful if inhaled. Keep away from sparks and

³ The sole source of supply of Methyl n-Propyl Ketone (MPK) known to the committee at this time is Eastman Chemical Company, Kingsport, TN, USA. If you are aware of alternative suppliers, please provide this information to ASTM International Headquarters. Your comments will receive careful consideration at a meeting of the responsible technical committee,¹ which you may attend.

open flames. Avoid breathing vapors and prolonged or repeated contact with the skin. Use with adequate ventilation.

6.2 Flammable solvents, acids, or alkalis, or other toxic compounds are occasionally found in the material used for aircraft maintenance. Take suitable precautions to prevent personnel injury.

7. Test Specimens

7.1 The test specimens of a given alloy shall be taken from the same sheet stock and shall measure 50.8 by 25.4 by 1.6 mm (2 by 1 by 0.06 in.) with a 3.2-mm (0.125-in.) diameter mounting hole suitably located at one end of the specimen. Test at least two and preferably three replicates in each concentration of maintenance chemical solution in accordance with 9.2. The total area of the specimen shall be taken as 28.2 cm² (4.4 in.²).

8. Test Specimen

8.1 Preheat the test specimens to 60 ± 2 °C (150 ± 5 °F) and immerse in a beaker containing Mineral Spirits, Type II, conforming to Specification D235. Swab the surface of the individual specimen thoroughly using clean forceps to hold the specimen and the cotton swab.

8.2 Shake off the excess solvent. Transfer and immerse the test specimens separately several times in a beaker of methyl n-propyl ketone.

8.3 Shake off excess methyl n-propyl ketone and dry in a vacuum desiccator or in a low temperature oven at 37.7 ± 3 °C (100 ± 5 °F) for 15 min.

9. Conditioning

9.1 *Volume of Solution*—The volume of solution shall be 500 mL per specimen. Use fresh solution for each set of replicates.

9.2 *Solution Concentration:*

9.2.1 Unless otherwise specified, test the specimens in solutions of the maintenance chemical in the concentrated as-received condition and at the recommended dilution using distilled or deionized water conforming to Specification D1193, Type IV. (For solid materials, concentrated condition shall mean in a saturated solution of the solid material.) In case the material is not soluble to the extent noted, record this fact and continue with the test.

9.2.2 Test diphasic materials with an appropriate amount of each phase loaded into the test vessel to simulate use conditions. Totally immerse the corrosion specimens in the working phase of the maintenance chemical.

9.2.3 If water is not used as the diluent, record the type and specification of diluent used in the test.

9.3 *Temperature*—Unless otherwise specified, the temperature shall be 37.7 ± 3 °C (100 ± 2 °F).

9.4 *Test Duration*—Total test duration shall be 168 h, with specimens being added or removed at intermediate intervals.

9.5 If the maintenance chemical is to be used with agitation, also test the specimens with appropriate agitation to simulate use conditions.

10. Procedure

10.1 Weigh four of five specimens (S_1 , S_2 , S_3 , and S_4) of the same alloy to the nearest 0.1 mg. Record the weights S_1 W_1 , S_2 W_1 , S_3 W_1 , S_4 W_1 . Retain the fifth specimen of each alloy for comparison purposes.

10.2 Immerse three of the specimens (S_1 , S_2 , and S_3) in the test solution using only specimens of the same alloy in the containing vessel. Retain S_4 for use in accordance with 10.5.

10.3 At the end of 48-h exposure time, remove S_1 and proceed as follows:

10.3.1 Rinse thoroughly under hot tap water, 49 to 60 °C (120 to 140 °F), while scrubbing with a stiff bristle brush. Follow with distilled or deionized water conforming to Specification D1193, Type IV at room temperature.

10.3.2 Rinse with a stream of acetone conforming to Specification D329 from a wash bottle and dry.

10.3.3 If corrosion deposits are still adhered, remove corrosion products in accordance with Annex A1 and Annex A2 and rinse dry in accordance with 10.3.1 and 10.3.2.

10.3.4 Weigh to the nearest 0.1 mg and record as S_1 W_2 . If the specimen has been treated in accordance with Annex A1 and Annex A2, subtract any weight losses of the control specimen of Annex A1 and Annex A2 from the weight loss of the specimen.

10.3.5 Calculate the weight loss of the panel as WL. $S_1 = S_1 W_1 - S_1 W_2$.

10.4 At the end of 120-h exposure time, remove S_2 and proceed in accordance with 10.3. Record the weight loss as $S_2 W_2$.

10.5 Also at the end of 120-h exposure time, add S_4 to the reaction vessel.

10.6 At the end of 168-h exposure time, remove S_3 and S_4 from the solution and proceed as follows:

10.6.1 Proceed in accordance with 10.3 for S_4 and record the weight loss as $S_4 W_2$.

10.6.2 For S_3 , rinse in accordance with 10.3.1 and 10.3.2, then examine for and record the following visible changes in comparison with the fifth virgin specimen:

10.6.2.1 Discoloration and dulling,

10.6.2.2 Etching,

10.6.2.3 Presence of accretions and relative amounts,

10.6.2.4 Pitting, and

10.6.2.5 Presence of selective or localized attack.

10.6.3 If any corrosion deposits remain, remove these products from S_3 in accordance with Annex A1 and Annex A2. Rinse with distilled water conforming to Specification D1193, Type IV followed by acetone conforming to Specification D329 and dry.

10.6.4 Weigh to the nearest 0.1 mg and calculate the weight loss as W_3 . If the specimen has been treated in accordance with Annex A1 and Annex A2, subtract any weight losses of the control specimen of Annex A1 and Annex A2, from the weight loss of the test specimen.

11. Report

11.1 Report the following data for each test performed:

11.1.1 Name and type of maintenance chemical tested.

11.1.2 Concentrations, diluent used, and other conditions of test peculiar to maintenance chemical type.

11.1.3 Alloy type, surface treatment and condition, and number of specimens tested.

11.1.4 Temperature, duration of test, and agitation if any.

11.1.5 Average corrosion rate, R_1 , R_2 , R_3 , R_4 , or weight loss in milligrams per square centimetre per day for each specimen where:

$$R = \frac{W/\text{surface area of panel in cm}^2}{\text{total exposure time of panel/24}}$$

11.1.6 Range in weight losses.

11.1.7 Effect of time on liquid corrosiveness and metal corrodibility calculated in accordance with Annex A3.

11.1.8 Appearance before and after removal of corrosion products with regard to the following:

11.1.8.1 Discoloration and dulling,

11.1.8.2 Etching,

11.1.8.3 Presence of accretions and relative amounts,

11.1.8.4 Pitting, and

11.1.8.5 Presence of selective or localized attack.

12. Keywords

12.1 aircraft metals; corrosion rates as weight loss per surface unit divided by exposure time per day; in concentrate; in use dilution; liquid corrosiveness; metal corrodibility; tank-type chemicals; temperature control; time control; total immersion corrosion; visual corrosive deterioration