



Designation: C1019 – 20

Standard Test Method for Sampling and Testing Grout for Masonry¹

This standard is issued under the fixed designation C1019; the number immediately following the designation indicates the year of original adoption or, in the case of revision, the year of last revision. A number in parentheses indicates the year of last reapproval. A superscript epsilon (ϵ) indicates an editorial change since the last revision or reapproval.

This standard has been approved for use by agencies of the U.S. Department of Defense.

1. Scope

1.1 This test method covers procedures for both field and laboratory sampling and compression testing of grout used in masonry construction. Grout for masonry is specified under Specification C476.

NOTE 1—The testing agency performing this test method should be evaluated in accordance with Practice C1093.

1.2 The values stated in inch-pound units are to be regarded as standard. The values given in parentheses are mathematical conversions to SI units that are provided for information only and are not considered standard.

1.3 *This standard does not purport to address all of the safety concerns, if any, associated with its use. It is the responsibility of the user of this standard to establish appropriate safety, health, and environmental practices and determine the applicability of regulatory limitations prior to use.*

1.4 *This international standard was developed in accordance with internationally recognized principles on standardization established in the Decision on Principles for the Development of International Standards, Guides and Recommendations issued by the World Trade Organization Technical Barriers to Trade (TBT) Committee.*

2. Referenced Documents

2.1 *ASTM Standards:*²

C39/C39M Test Method for Compressive Strength of Cylindrical Concrete Specimens

C143/C143M Test Method for Slump of Hydraulic-Cement Concrete

C476 Specification for Grout for Masonry

C511 Specification for Mixing Rooms, Moist Cabinets, Moist Rooms, and Water Storage Tanks Used in the

¹ This test method is under the jurisdiction of ASTM Committee C12 on Mortars and Grouts for Unit Masonry and is the direct responsibility of Subcommittee C12.02 on Research and Methods of Test.

Current edition approved Dec. 1, 2020. Published December 2020. Originally approved in 1984. Last previous edition approved in 2019 as C1019 – 19. DOI: 10.1520/C1019-20.

² For referenced ASTM standards, visit the ASTM website, www.astm.org, or contact ASTM Customer Service at service@astm.org. For *Annual Book of ASTM Standards* volume information, refer to the standard's Document Summary page on the ASTM website.

Testing of Hydraulic Cements and Concretes

C617 Practice for Capping Cylindrical Concrete Specimens

C1064/C1064M Test Method for Temperature of Freshly Mixed Hydraulic-Cement Concrete

C1093 Practice for Accreditation of Testing Agencies for Masonry

C1611/C1611M Test Method for Slump Flow of Self-Consolidating Concrete

3. Significance and Use

3.1 Grout used in masonry is a fluid mixture of cementitious materials and aggregate with a high water content for ease of placement.

3.1.1 During construction, grout is placed within or between absorptive masonry units. Excess water must be removed from grout specimens in order to provide compressive strength test results more nearly indicative of the grout strength in the wall. In this test method, molds are made from masonry units having the same absorption and moisture content characteristics as those being used in the construction.

3.2 This test method is used to either help select grout proportions by comparing test values or as a quality control test for uniformity of grout preparation during construction.

3.3 The physical exposure condition and curing of the grout are not exactly reproduced, but this test method does subject the grout specimens to absorption conditions similar to those experienced by grout in the wall.

NOTE 2—Test results of grout specimens taken from a wall should not be compared to test results obtained with this test method.

4. Apparatus

4.1 *Maximum-Minimum Thermometer.*

4.2 *Straightedge*, a steel straightedge not less than 6 in. (152.4 mm) long and not less than 1/16 in. (1.6 mm) in thickness.

4.3 *Tamping Rod*, a round, straight, steel rod with a diameter of 3/8 ± 1/16 in. (10 ± 2 mm) and a length of 12 ± 4 inches. (300 ± 100 millimetres). The rod shall have the tamping end or both ends rounded to a hemispherical tip of the same diameter as the rod.

*A Summary of Changes section appears at the end of this standard

4.4 *Nonabsorbent Blocks and Spacers*, nonabsorbent, rigid squares and rectangles with side dimensions so as to achieve the desired grout specimen side dimensions and of sufficient quantity or thickness to yield the desired grout specimen height, as shown in Fig. 1, Fig. 2, and Fig. 3.

NOTE 3—Nonabsorbent blocks may be of plastic, wood, or other nonabsorbent material. Certain species of wood contain sugars which cause retardation of cement. In order to prevent this from occurring, new wooden blocks shall be soaked in limewater for 24 h, sealed with varnish or wax, or covered with an impermeable material prior to use.

4.5 *Framing Square*, a framing square not less than 6 in. (150 mm) long and not less than 1/16 in. (2 mm) in thickness.

4.6 *Panels and plates*, pieces of 3/4 in. (19 mm) plywood with dimensions as needed to contain units and grout specimens. Soak in limewater for 24 h, seal with varnish or wax, or cover with an impermeable material prior to use. A nonabsorbent material of equivalent stiffness to the plywood is permitted.

PROCEDURES

5. Grout Specimen Molds

5.1 *Molds from Masonry Units*:

5.1.1 Select a level location where the molds remain undisturbed for up to 48 h.

NOTE 4—The location of specimen construction should be protected and as free from perceptible vibration as possible.

5.1.2 The construction of the mold shall simulate the in-situ construction. If the grout is placed between two different types of masonry units, both types shall be used to construct the mold.

5.1.3 Form specimen molds by arranging masonry units of the same type and moisture condition as those being used in the construction. The surface of the units in contact with the grout specimen shall not have been previously used to mold the specimens. Place a non-absorbent block as described in 4.4, cut to the proper size and of the proper thickness or quantity, at the bottom of the space to achieve the necessary height of the specimen. Specimen molds shall comply with the following:

5.1.3.1 Molds shall have a cross-section that is nominally square.

5.1.3.2 Molds shall have a width of 3.0 in. (76 mm) to 3.75 in. (95 mm).

5.1.3.3 Molds shall have a height of at least twice the width (see Note 5).

NOTE 5—The final specimen height requirement is defined in 5.1.3 as being 1.75 to 2.0 times the specimen width. The intent of the standard is to target a specimen height two times the specimen width while allowing

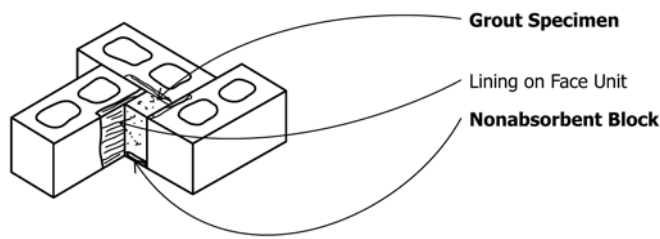

FIG. 2 Example of Grout Mold (Units Greater than 6 in. (152.4 mm) High, 8 in. (203.2 mm) High Concrete Masonry Unit Shown)

some tolerance in those cases where the specimen would need to be cut down in height to meet the perpendicularity requirements. Having a mold that has a height at least twice the specimen width allows the final specimen to be cut to meet the requirement or be cut to meet the requirement.

5.1.4 Line the masonry surfaces that will be in contact with the grout specimen with a thin, permeable material to prevent bond to the masonry units. New lining material shall be used for each specimen.

NOTE 6—The lining, such as paper towel, is used to aid in stripping the grout specimen from the mold. Proper installation of the lining prevents irregularly sized specimens and varying test results.

5.1.5 See Figs. 1-3 and accompanying notes for example of mold construction that conform with 5.1.2, 5.1.3, and 5.1.4.

5.1.6 Brace units to prevent displacement during grouting and curing.

5.2 *Alternative Methods*—Alternative methods of forming the specimens shall be used only with the approval of the specifier. Such approval shall be based on comparative testing of grout specimens constructed from molds as described in 5.1 and the alternative method. Approval shall be limited to a single specimen shape, method of forming, masonry units used, and grout mix. A conversion factor based on comparative testing of a minimum of ten pairs of specimens shall be used to modify results from alternative methods. The coefficient of variation of test results of specimens formed by the alternative method shall be less than or equal to that of the specimens formed in accordance with 5.1.

NOTE 7—Other methods of obtaining grout specimens and specimens of different geometry have been employed in grout testing, but are not described in this test method. Other methods used to obtain grout specimens include: drilling grout-filled cores of regular units; filling cores of masonry units specifically manufactured to provide grout specimens; filling compartments in slotted corrugated cardboard boxes specifically manufactured to provide grout specimens; and forming specimens from different sized masonry units of the same or similar material.

Since test results vary with methods of forming the specimen, specimen geometry, and grout mix, comparative test results between specimens made with molds described in 5.1 and specimens made with alternative methods are required and confined to a single specimen shape, method of forming, masonry units used, and grout mix.

6. Test Specimens

6.1 Specimens shall comply with the following:

6.1.1 Specimens shall have a nominally square cross section.

6.1.2 Specimens shall have an average specimen width between 3 in. (76 mm) and 3.75 in. (95 mm).

6.1.3 Specimens shall have a height before capping between 1.75 and 2.0 times the specimen width.

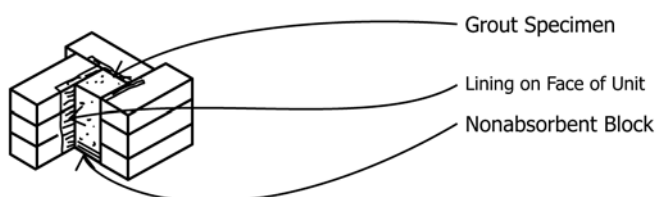

FIG. 1 Example of Grout Mold (Units 6 in. (152.4 mm) or Less in Height, 2 1/4 in. (57.2 mm) High Brick Shown)

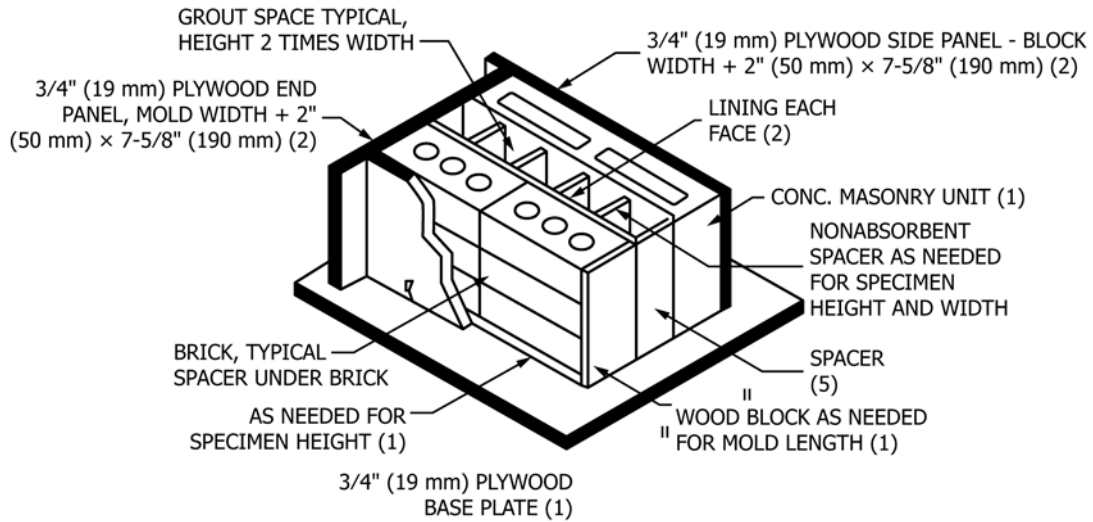

FIG. 3 Example of Grout Mold with Brick and Concrete Masonry Units

6.1.4 For each specimen, the difference between any width measurement and the average width for that specimen shall not exceed 1/8 in. (3.2 mm).

6.1.5 Neither end of the test specimen shall depart from perpendicularity to the vertical axis by more than 1 degree (approximately equivalent to 1/8 in. in 6 in.) (1 mm in 50 mm).

6.1.6 Specimens shall have side surfaces that are plane to within 1/8 in. in 6 in. (1 mm in 50 mm). See Fig. 4.

NOTE 8—Subsection 10.7 provides for cutting or grinding the top or bottom of hardened specimens to achieve dimensional requirements.

6.2 Test at least three specimens at each age specified.

NOTE 9—Frequency of sampling and age of test is to be determined by the specifier of this test method and is usually found in the construction documents.

7. Sampling Grout

7.1 *Size of Sample*—Grout samples to be used for slump and compressive strength tests shall be a minimum of 1/2 ft³ (0.014 m³).

7.2 *Procedure*—The procedures used in sampling shall include the use of precautions that will assist in obtaining samples that are representative of the nature and condition of

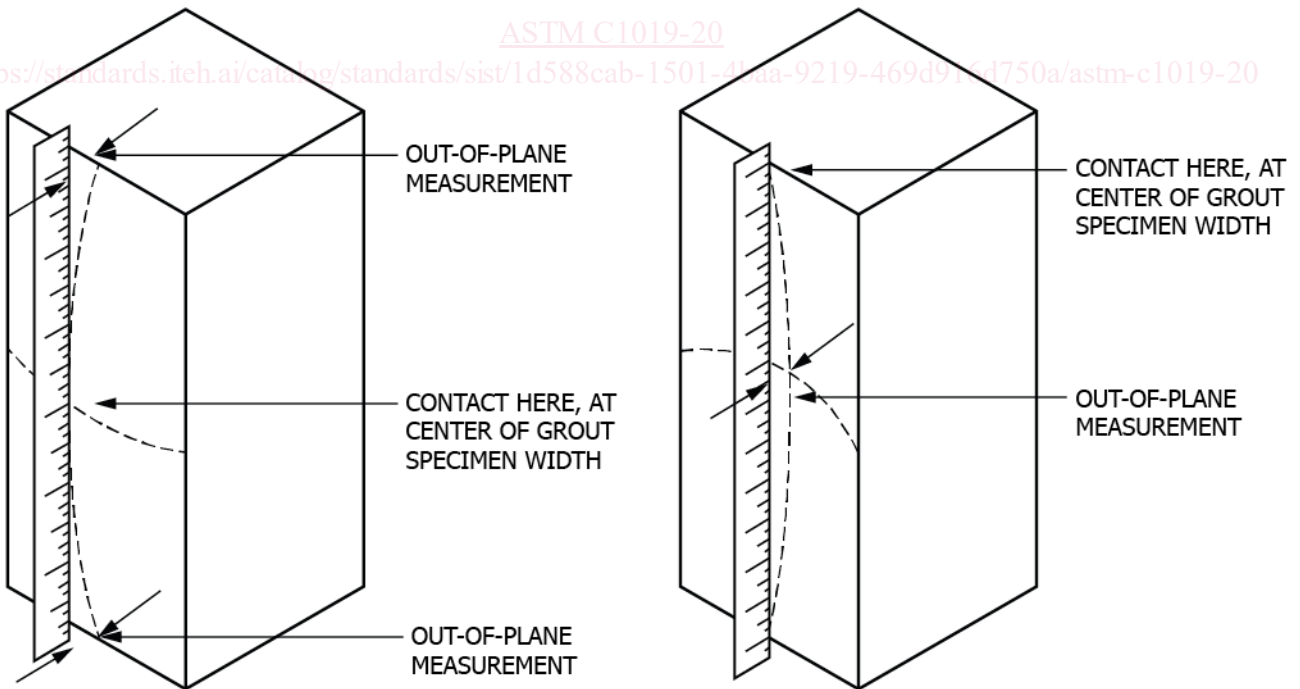

FIG. 4 Out-of-plane Measurement

the grout. After the final slump adjustment has been made, sample grout as the grout is being placed.

7.2.1 Field Sampling—Collect two or more portions taken at regularly spaced intervals during the discharge of the middle portion of the batch. The elapsed time between obtaining the first and final portions of the sample shall be not more than 15 min.

7.2.2 Laboratory Sampling—The entire mixed batch of grout is the sample.

NOTE 10—The field technician sampling, making, and curing specimens for acceptance testing should be certified (American Concrete Institute Field Testing Technician—Grade I, National Concrete Masonry Association Masonry Testing Technician, or equivalent). Equivalent certification programs should include both written and performance examinations.

7.3 Place the grout sample in a non-absorptive container and cover the top to protect the sample from the sun, wind, and any other sources of rapid evaporation and from contamination. Transport the grout sample to the mold location. Remix the sample with a shovel or trowel to ensure uniformity prior to filling molds. Keep remaining grout sample protected in a covered, non-absorptive container until used to fill any depression in the sample due to initial water loss.

8. Temperature and Slump Test

8.1 Measure and record the temperature of the grout sample in accordance with Test Method **C1064/C1064M**.

8.2 Begin filling the slump cone within 5 min of obtaining the final portion of the sample.

8.3 For all grout except self-consolidating grout, measure and record the slump in accordance with the requirements of Test Method **C143/C143M**.

8.4 For self-consolidating grout, measure and record the slump flow in accordance with the requirements of Test Method **C1611/C1611M** and visual stability index (VSI) in accordance with the requirements of Test Method **C1611/C1611M**, Appendix X1.

9. Compressive Test Specimen

9.1 If grout from the slump or slump flow test is used for the compressive test specimens, remix the sample. Begin filling the compressive strength molds within 15 min of obtaining the final portion of the sample.

9.2 For all grout except self-consolidating grout, fill the mold with grout in two layers of approximately equal depth. Rod each layer 15 times with the tamping rod. Rod the bottom layer through its depth. Slightly overfill the mold. Rod the second layer with the tamping rod penetrating approximately 1/2 in. (12.7 mm) into the lower layer. Distribute the strokes uniformly over the cross section of the mold.

9.3 For self-consolidating grout, fill the mold with grout in one layer and do not rod.

9.4 Strike off the top surface of the specimen with a straightedge to produce a flat surface that is even with the top edge of the mold and that has no depressions or projections larger than 1/8 in. (3.2 mm). Cover immediately with a damp absorbent material such as cloth or paper towel. Keep the top

surface of the specimens damp by wetting the absorbent material and covering with a nonabsorbent, nonreactive material to retain the moisture. Do not disturb the specimens.

9.5 Between 15 and 30 min after filling the mold, add sufficient grout without rodding to fill the depression caused by initial water loss. Strike off the top surface of the specimen with a straightedge to produce a flat surface that is even with the top edge of the mold. Cover immediately with a damp absorbent material such as cloth or paper towel. Keep the top surface of the specimen damp by wetting the absorbent material and covering with a nonabsorbent, nonreactive material. Do not disturb the specimen until the molds are removed.

NOTE 11—The viscosity of self-consolidating grout changes with time. Thus the depression may require filling prior to the thirty minute limit.

9.6 Protect the specimens from freezing and variations in temperature. Store an indicating maximum-minimum thermometer with the specimens and record the maximum and minimum temperatures experienced prior to the time the specimens are placed in the final curing environment.

NOTE 12—If storage temperatures are less than 60°F (15.6°C) or greater than 80°F (26.7°C) as shown by the thermometer, the resulting compressive strength will likely be affected.

10. Transportation, Curing, and Testing of the Specimens

10.1 Remove the molds between 24 and 48 h after making the specimens.

NOTE 13—Various conditions, such as the use of set retarders or low ambient temperatures, may necessitate delaying mold removal until well after 24 h. Care should be taken to ensure the specimens have achieved sufficient strength for transportation, which may include delaying mold removal and transportation until 48 h.

10.2 Within 30 min after removing the molds, place specimens in a protective container and keep specimens damp.

10.3 Transport field specimens to the laboratory within 8 h after mold removal.

10.4 Within 8 h after mold removal, place in a moist room, moist cabinet, or water storage tank conforming to Specification **C511**. Store there until day of testing.

10.5 Keep specimen damp until tested.

10.6 Specimen Measurement:

10.6.1 Measure and record the width of all four faces at mid-height to the nearest 1/16 in. (2 mm).

10.6.2 Measure and record the height of all four faces at mid-width to the nearest 1/16 in. (2 mm).

10.6.3 Measure and record the perpendicularity from the top and bottom surfaces at mid-width of each face to the nearest 1/16 in. (2 mm). See **Fig. 5**.

10.6.4 Measure and record the amount out-of-plane at mid-width of each side surface to the nearest 1/16 in. (2 mm). See **Fig. 5**. Specimens that are beyond the out-of-plane tolerances shall not be tested.

10.7 It is permissible to cut or grind the top, bottom or both of specimens that are beyond the tolerances listed in **6.1.3** or **6.1.5** prior to capping and testing the specimens provided the resulting ratio of average height to average width (h/w) is between 1.75 and 2.0. Reported measurements shall be based on measurements after cutting or grinding is completed.

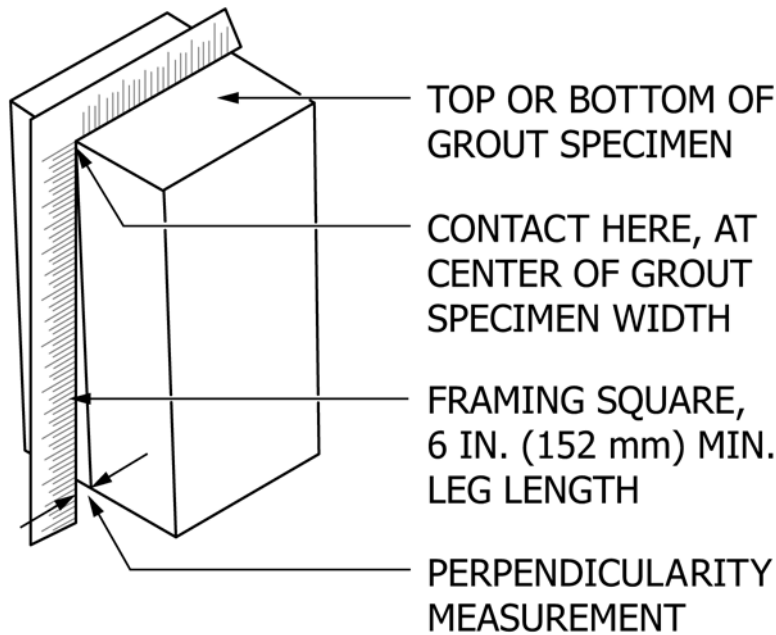

FIG. 5 Perpendicularity Measurement

10.8 Cap the specimens in accordance with the applicable requirements of Practice C617.

NOTE 14—Practice C617 refers to capping cylindrical specimens; therefore, the alignment devices may need to be modified to ensure proper use with the rectangular prism specimens of this method. All other sections of Practice C617 are applicable.

10.9 Test the specimens in a damp condition in accordance with the applicable requirements of Test Method C39/C39M.

11. Calculations

11.1 Determine the average width by averaging the four width measurements. Determine the average height by averaging the four height measurements.

11.2 Determine the average cross-sectional area by calculating the average width of opposite faces, and multiplying the averages.

11.3 For specimens from molds of masonry units, calculate the compressive strength by dividing the maximum load by the average cross-sectional area and express the result to the nearest 10 psi (50 kPa).

11.4 For specimens from alternative methods of forming, calculate a conversion factor between the results obtained from comparative testing by dividing the average compressive strength of the specimens formed in accordance with 5.1 by the average compressive strength of the specimens formed by the alternative method. Calculate the average corrected compressive strength by dividing the maximum load by the average cross-sectional area and multiplying the result by the conversion factor. Express the result to the nearest 10 psi (50 kPa).

11.5 When specimens are formed using alternative methods as described in 5.2, calculate the coefficient of variation for results obtained from comparative testing by dividing the standard deviation of each method by its mean.

12. Report

12.1 For all specimens, the report shall include the following (see Note 15):

NOTE 15—See Appendix XI for an example of a report.

12.1.1 Grout mix design,

12.1.2 Grout slump for all grouts except self-consolidating grout,

12.1.3 Slump flow and visual stability index (VSI) value of the grout for self-consolidating grout,

12.1.4 Description of the specimens—individual and average width and height dimensions.

12.1.5 Curing history, including initial temperature, maximum and minimum temperatures, and age of specimens when transported to laboratory and when tested,

12.1.6 Maximum load and compressive strength of each specimen, average compressive strength of the specimens, and standard deviation, and

TABLE 1 Statistics of Laboratory-Prepared Specimens

Number of Specimens	Mean, psi (MPa)	Standard Deviation, psi (MPa)	Coefficient of Variation, %
3	4196 (28.9)	73.8 (0.51)	1.18
3	4455 (30.7)	50.8 (0.35)	1.87
3	6014 (41.5)	323 (2.28)	5.25
3	6196 (42.7)	148 (1.02)	2.38
3	7292 (50.3)	600 (4.14)	8.23
5	3784 (26.1)	306 (2.11)	8.1
5	2494 (17.2)	220 (1.52)	8.8
5	3178 (21.9)	634 (4.37)	20.0
6	5480 (37.8)	899 (6.2)	16.4
10	5350 (36.9)	826 (5.7)	15.4
12	3872 (26.7)	333 (2.30)	8.6
15	3468 (23.9)	154 (1.06)	4.46
15	3478 (24.0)	253 (1.75)	7.27
20	2617 (18.1)	127 (0.88)	4.85
20	2627 (18.12)	125 (0.86)	4.76