



Designation: C849 – 88 (Reapproved 2020)

Standard Test Method for Knoop Indentation Hardness of Ceramic Whitewares¹

This standard is issued under the fixed designation C849; the number immediately following the designation indicates the year of original adoption or, in the case of revision, the year of last revision. A number in parentheses indicates the year of last reapproval. A superscript epsilon (ϵ) indicates an editorial change since the last revision or reapproval.

1. Scope

1.1 This test method covers the determination of the Knoop indentation hardness of ceramic whitewares and the verification of Knoop indentation hardness testing machines using standard glasses.

1.2 *This standard does not purport to address all of the safety concerns, if any, associated with its use. It is the responsibility of the user of this standard to establish appropriate safety, health, and environmental practices and determine the applicability of regulatory limitations prior to use.*

1.3 *This international standard was developed in accordance with internationally recognized principles on standardization established in the Decision on Principles for the Development of International Standards, Guides and Recommendations issued by the World Trade Organization Technical Barriers to Trade (TBT) Committee.*

2. Referenced Documents

2.1 *ASTM Standards:*²

E4 Practices for Force Verification of Testing Machines

E384 Test Method for Microindentation Hardness of Materials

3. Terminology

3.1 *Definitions:*

3.1.1 *Knoop hardness number (KHN)*—a number obtained by dividing the applied load in kilograms-force by the projected area of the indentation in square millimetres, computed from the measured long diagonal of the indentation and the included edge angles of the diamond; it is assumed that the indentation is an imprint of the undeformed indenter.

4. Summary of Test Method

4.1 This test method describes an indentation hardness test using a calibrated machine to force a pointed, rhombic-base,

¹ This test method is under the jurisdiction of ASTM Committee C21 on Ceramic Whitewares and Related Products and is the direct responsibility of Subcommittee C21.03 on Methods for Whitewares and Environmental Concerns.

Current edition approved Nov. 1, 2020. Published December 2020. Originally approved in 1976. Last previous edition approved in 2016 as C849 – 88 (2016). DOI: 10.1520/C0849-88R20.

² For referenced ASTM standards, visit the ASTM website, www.astm.org, or contact ASTM Customer Service at service@astm.org. For *Annual Book of ASTM Standards* volume information, refer to the standard's Document Summary page on the ASTM website.

pyramidal diamond indenter having specified face angles, under a predetermined load, into the surface of the material under test and to measure the long diagonal of the resulting impression after removal of the load.

NOTE 1—A general description of the Knoop indentation hardness test is given in Test Method E384. The present method differs from this description only in areas required by the special nature of ceramic whitewares.

5. Significance and Use

5.1 The Knoop indentation hardness is one of many properties that is used to characterize ceramic whitewares. Attempts have been made to relate Knoop indentation hardness to tensile strength, grinding speeds, and other hardness scales, but no generally accepted methods are available. Such conversions are limited in scope and should be used with caution, except for special cases where a reliable basis for the conversion has been obtained by comparison tests.

6. Apparatus

6.1 *Testing Machines:*

6.1.1 There are two general types of machines available for making this test. One type is a self-contained unit built for this purpose, and the other type is an accessory available to existing microscopes. Usually, this second type is fitted on an inverted-stage microscope. Good descriptions of the various machines are available.^{3,4}

6.1.2 Design of the machine should be such that the loading rate, dwell time, and applied load can be standardized within the limits set forth in 3.1.1. It is an advantage to eliminate the human element whenever possible by appropriate machine design. The machine should be designed so that vibrations induced at the beginning of a test will be damped out by the time the indenter touches the sample.

6.1.3 The calibration of the balance beam should be checked monthly or as needed. Indentations in standard glasses are also used to check calibration when needed.

6.2 *Indenter:*

³ Specifications for Knoop indenters can be found in Small, L., *Hardness Theory and Practice, Part 1*, Service Diamond Tool Co., Ann Arbor, MI, 1960, pp. 241–243.

⁴ Mott, B. W., *Micro-Indentation Hardness Testing*, Butterworth's Scientific Publications, London, 1956.

6.2.1 The indenter shall meet the specifications for Knoop indenters.³ See Test Method E384.

6.2.2 Fig. 1 shows the indenter and its maximum usable dimensions. The diagonals have an approximate ratio of 7:1, and the depth of the indentation is about $\frac{1}{30}$ the length of the long diagonal. A perfect Knoop indenter has the following angles:

6.2.2.1 Included longitudinal angle $172^\circ 30' 00''$.

6.2.2.2 Included transverse angle $130^\circ 00' 00''$.

6.2.3 The constant C_p for a perfect indenter is 0.070 28, and the specifications require a variation of not more than 1 % from this value.

6.3 *Measuring Microscope*—The measurement system shall be so constructed that the length of the diagonals can be determined with errors not exceeding ± 0.0005 mm. The apparent length of the diagonal is corrected in the calculations for the limit of resolution of the objective being used in the microscope.

7. Test Specimens

7.1 The Knoop indentation hardness test is adaptable to a wide variety of ceramic whiteware specimens. In general, the accuracy of the test will depend on the smoothness of the surface and, whenever possible, ground and polished specimens should be used. The back of the specimen shall be fixed so that the specimen cannot rock or shift during the test.

7.1.1 *Thickness*—As long as the specimen is over ten times as thick as the indentation depth, this will not affect the test. In general, if specimens are at least 0.10 mm thick, the hardness will not be affected by variations in the thickness.

7.1.2 *Surface Finish*—As pointed out above, the accuracy of the test depends on the surface finish. However, if one is investigating a surface coating or treatment, he cannot grind and polish the sample. Experience has shown that six indentations on a ground and polished surface of glass will reproduce within $\pm 1\%$. Six indentations on an “as-received” surface may be as bad as $\pm 10\%$. Ground and polished surfaces should be used. If this is not possible, the number of indentations should be increased.

7.1.3 *Radius of Curvature*—The KHN obtained will be affected even when the curvature is only in the direction of the short diagonal. Care should be used when relating KHN values obtained on curved surfaces to those obtained on polished flat surfaces.

8. Preparation of Apparatus

8.1 *Verification of Load*—Most of the machines available for Knoop hardness testing use a loaded beam. This beam should be tested for zero load. An indentation should not be visible with zero load, but the indenter should contact the sample. A visible indentation should be obtained with a load of 0.1 gf. Other methods of verifying the load application are given in Practice E4.

8.2 *Verification by Standard Glasses*—Table 1 gives the Knoop hardness of several National Institute of Standards and Technology (NIST) standard glasses. Knoop hardness measurement on a piece of one of these glasses that has been ground and polished within the last 24 h should agree with the value in the table $\pm 5\%$. Tests should be made using 100 gf.

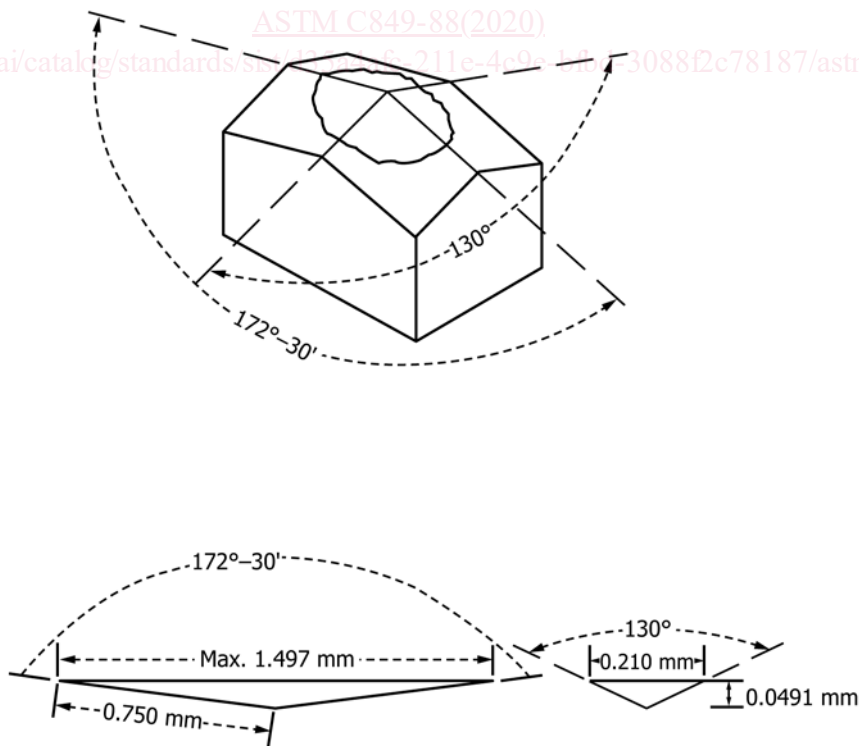

FIG. 1 Knoop Indenter Showing Maximum Usable Dimension

TABLE 1 Knoop Hardness of NIST Standard Glasses^{A,B}

Laboratory	NIST 710	NIST 711	NIST 715	GE Fused Quartz	NIST 710	NIST 711	NIST 715	GE Fused Quartz
	25 gf Load				50 gf Load			
A	486	411	589	614	497	394	575	559
C	594	450			537	415		
D	479	426	505	541	478	380	538	501
E	521	415	608	620	497	392	574	586
F	498	414	568	643	484	403	567	577
G								
Av	516	423	567.5	609.5	499	397	563.5	556
Departure, max, %	15	6	11	11	8	5	5	10
Range, max, %	22	9	18	17	12	9	7	15
	100 gf Load				200 gf Load			
A	475	387	558	554	468	380	550	523
C	478	387	554	593	468	371	544	530
D	452	368	521	473	433	360	529	474
E	490	396	544	530	488	372	546	510
F	467	381	538	524	457	367	524	502
G	481	388	550	558				
Av	474	384.5	544	539	463	370	539	508
Departure, max, %	5	4	4	12	6	3	3	7
Range, max, %	8	7	7	22	12	5	5	11

^A NIST 710—NIST standard soda-lime-silica glass. NIST 711—NIST standard lead-silica glass. NIST 715—NIST standard alkali-free aluminosilicate glass.

^B These data were obtained from ASTM round-robin testing.

9. Procedure

9.1 *Specimen Placement*—Place the specimen on the stage of the machine in such a way so that the specimen will not be able to rock or shift during the measurement.

9.2 Specimen Leveling:

9.2.1 The surface of the specimen being tested must lie in a plane normal to the axis of the indenter. Fig. 2 shows an indentation as it will appear through the microscope with five points labeled. To level the specimen, make a test indentation using a 100 gf load.

9.2.2 The following minimum specifications must be met:

$$OA = OB \pm 5\% \quad (1)$$

$$OC = OD \pm 5\%$$

9.2.3 Leveling the specimen to meet these specifications is facilitated if one has a leveling device.

9.3 *Magnitude of Test Load*—A test load of 1000 gf (9.8 N) is specified. If cracks develop at this load, measurements within 500- or 250 gf (4.9- or 2.45 N) loads may be made although the Knoop indentation hardness does vary with load. Table 1 gives an indication of the magnitude of this variation to be expected. In all cases, the load actually used should be reported.

9.4 Application of Test Load:

9.4.1 Start the machine smoothly. The rate of indenter motion before contact with the specimen shall be 0.20 ± 0.05 mm/min. If the machine is loaded by an electrical system or a dash-pot lever system, it should be mounted on shock absorbers which damp out all vibrations by the time the indenter touches the specimen. If the specimen is handloaded, take extreme care to see that the loading rate never goes higher than 0.25 mm/min.

9.4.2 The indenter should remain in contact with the specimen between 20 and 30 s. After the indenter has been in

contact with the specimen for the required dwell time, carefully raise it off the sample to avoid a vibration impact at this time.

9.5 *Spacing of Indentations*—Allow a distance of at least three times the short diagonal between indentations.

9.6 *Number of Indentations*—The number of indentations will vary with the type of specimen. For example, if one is investigating the hardness gradient in a sample, he will make a series of indentations and plot the KHN as a function of distance. In the usual test, one has a piece of ceramic whiteware that is fairly homogeneous and he is trying to obtain a mean KHN for that specimen. In this case, it is recommended that at least ten indentations be made and that both the mean KHN and the standard deviation be reported. The standard deviation is:

$$s = \sqrt{\sum (KHN - KHN_n)^2 / (n - 1)} \quad (2)$$

where:

- s = standard deviation of a single observation,
- KHN = mean KHN,
- KHN_n = KHN obtained from nth indentation, and
- n = number of indentations.

10. Measurement of Indentation

10.1 The accuracy of the test method depends to a very large extent on this measurement, as follows:

10.1.1 If the measuring system contains a light source, take care to use the system only after it has reached equilibrium temperature. This is because the magnification of a microscope depends on the tube length.

10.1.2 Carefully calibrate the measuring system with a stage micrometer or, better, with a grating.

10.1.3 If either a measuring microscope or a filar micrometer is used, always rotate the drum in the same direction to eliminate backlash errors.