



Designation: D3753 – 20

# Standard Specification for Fiberglass (Glass-Fiber-Reinforced Thermosetting-Resin) Manholes and Wetwells<sup>1</sup>

This standard is issued under the fixed designation D3753; the number immediately following the designation indicates the year of original adoption or, in the case of revision, the year of last revision. A number in parentheses indicates the year of last reapproval. A superscript epsilon ( $\epsilon$ ) indicates an editorial change since the last revision or reapproval.

## 1. Scope\*

1.1 This specification covers “fiberglass” (glass fiber-reinforced thermosetting-resin) manholes and wetwells fabricated with polyester, vinyl ester, or epoxy resin for use primarily in sanitary, storm, and industrial sewer applications.

1.2 The values given in inch-pound units are to be regarded as the standard. The values in parentheses are provided for information purposes only.

1.3 The following precautionary caveat pertains only to the test methods portion, Section 8, of this specification: *This standard does not purport to address all of the safety concerns, if any, associated with its use. It is the responsibility of the user of this standard to establish appropriate safety, health, and environmental practices and determine the applicability of regulatory limitations prior to use.*

NOTE 1—There is no known ISO equivalent to this standard.

1.4 *This international standard was developed in accordance with internationally recognized principles on standardization established in the Decision on Principles for the Development of International Standards, Guides and Recommendations issued by the World Trade Organization Technical Barriers to Trade (TBT) Committee.*

## 2. Referenced Documents

2.1 *ASTM Standards:*<sup>2</sup>

[D581 Practice for Determining Chemical Resistance of Thermosetting Resins Used in Glass-Fiber-Reinforced Structures Intended for Liquid Service](#)

[D695 Test Method for Compressive Properties of Rigid Plastics](#)

[D785 Test Method for Rockwell Hardness of Plastics and](#)

[Electrical Insulating Materials](#)

[D790 Test Methods for Flexural Properties of Unreinforced and Reinforced Plastics and Electrical Insulating Materials](#)

[D883 Terminology Relating to Plastics](#)

[D1600 Terminology for Abbreviated Terms Relating to Plastics](#)

[D2412 Test Method for Determination of External Loading Characteristics of Plastic Pipe by Parallel-Plate Loading](#)

[D2583 Test Method for Indentation Hardness of Rigid Plastics by Means of a Barcol Impressor](#)

[D2584 Test Method for Ignition Loss of Cured Reinforced Resins](#)

[D3892 Practice for Packaging/Packing of Plastics](#)

## 3. Terminology

3.1 *General*—Definitions are in accordance with Terminology [D883](#) and the abbreviations are in accordance with Terminology [D1600](#) unless otherwise indicated.

3.2 *bench and invert, n*—internal flow channel with a sloped bench extending from the edge of the flow channel to the manhole wall designed to facilitate the flow of liquid through the manhole between the pipe connectors.

3.3 *bottom, n*—a flat, domed, dished, or other shaped bottom designed to make the manhole or wetwell watertight at its base.

3.4 *expanded base manhole, n*—a manhole with a larger diameter base section and reduced diameter riser section. (See [Fig. 1](#) for a typical manhole and an expanded base manhole.)

3.5 *expanded base reducer, n*—a portion of the manhole, between the manway reducer and bottom, that changes from one diameter to another in the cylindrical portion of the structure.

3.6 *manway reducer, n*—the top portion of the manhole through which entrance to the manhole is made and where the diameter increases from the entrance way to the larger manhole cylinder.

3.7 *manhole, n*—a constant diameter cylinder attached to a manway reducer designed to handle a manhole cover and ring.

3.8 *manhole cover and frame, n*—those accessories used with the manhole to close the manway entrance (includes grade adjustment rings).

<sup>1</sup> This specification is under the jurisdiction of ASTM Committee [D20](#) on Plastics and is the direct responsibility of Subcommittee [D20.23](#) on Reinforced Thermosetting Resin Piping Systems and Chemical Equipment.

Current edition approved Dec. 1, 2020. Published December 2020. Originally approved in 1979. Last previous edition approved in 2019 as D3753 – 19. DOI: 10.1520/D3753-20.

<sup>2</sup> For referenced ASTM standards, visit the ASTM website, [www.astm.org](http://www.astm.org), or contact ASTM Customer Service at [service@astm.org](mailto:service@astm.org). For *Annual Book of ASTM Standards* volume information, refer to the standard's Document Summary page on the ASTM website.

\*A Summary of Changes section appears at the end of this standard

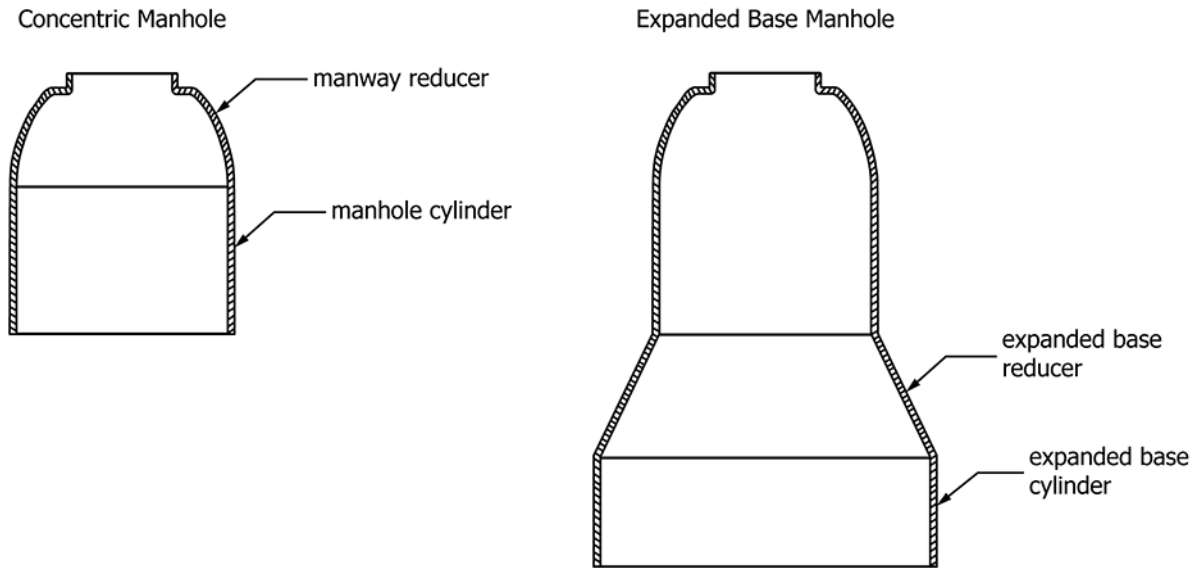

FIG. 1 Typical Manhole and Expanded Base Manhole

3.9 *manhole cylinder, n*—the portion below the manway reducer that extends in a constant diameter to the manhole base.

3.10 *pipe connectors, n*—connectors that provide access for the sewer pipe into the manhole.

3.11 *resin rich, adj*—describes that portion of the glass fiber-reinforced thermosetting-resin material where the resin-to-glass ratio is significantly greater than in other portions of the manhole.

3.12 *wetwell, n*—a cylindrical structure which is permitted to be open at the top or include a top.

3.13 *wetwell top, n*—a flat, domed, dished or other shaped top attached at the top of a wetwell structure. The top may include ribs or other structures to add stiffness. Stiffening features are permitted to be added to the interior or exterior surface, and may be integral or added as a secondary feature. It is permitted to use a similar top on manholes.

**4. Materials**

4.1 *Resin*—The resins used shall be a commercial grade thermosetting unsaturated polyester, vinyl ester or epoxy resin.

4.2 *Reinforcing Materials*—The reinforcing materials shall be commercial grade of E-type glass fibers in the form of mat, continuous roving, chopped roving, or roving fabric, having a coupling agent that will provide a suitable bond between the glass reinforcement and the resin.

4.3 *Surfacing Material*—If reinforcing material is used on the surface exposed to the contained substance, it shall be a commercial grade chemical-resistant glass or organic surfacing mat having a coupling agent that will provide a suitable bond with the resin.

4.4 *Fillers and Additives*—Fillers, such as sand, calcium carbonate, etc., when used, shall be inert to the environment and manhole or wetwell construction. Additives, such as thixotropic agents, catalysts, promoters, pigments, etc., are

permitted to be added as required by the specific manufacturing process to be used to meet the requirements of this standard. The resulting reinforced-plastic material shall meet the requirement of this specification. Use of fillers is permitted when agreed upon between fabricator and purchaser. See Note 2.

NOTE 2—The use of paints, coatings, pigments, dyes, colorants and fillers may interfere with visual inspection of the laminate.

4.5 *Other Materials*—The use of polyester filaments, polyester scrim, glass fiber scrim, or similar material as processing aids is permitted. The resulting reinforced-plastic material shall meet the requirement of this specification.

4.6 *Ribs*—When used, ribs are permitted to be manufactured as a solid construction or with materials applied over a structural or non-structural form. The resulting reinforced-plastic material shall meet the requirement of this specification.

**5. Manufacture**

5.1 Manholes, wetwells, manway reducers, eccentric or concentric reducers, connectors, tops and bottoms shall be produced from glass fiber-reinforced thermosetting resin with construction determined by the particular process of manufacture and configuration. The process is permitted to include contact molding, compression molding, pultrusion, filament winding, resin transfer molding, spray up, hand lay-up, centrifugal casting, vacuum bagging, or other methods. Ribs are permitted to be attached to the interior or the exterior surface.

5.2 *Interior Access*—All manholes and wetwells shall be designed so that a ladder or step system can be supported by the installed manhole or wetwell.

5.3 *Manway Reducer*—Manway reducers are permitted to be eccentric or concentric with respect to the larger portion of the manhole.

5.4 *Cover and Ring Support*—Manholes shall provide an area from which a typical ring and cover plate can be supported without damage to the manhole.

5.5 *Assembly Joints*—Product segments are permitted to be joined together to form a complete manhole or wetwell.

5.6 *Manhole or Wetwell Bottom*—Bottom shall be designed to be water tight and withstand the external hydraulic pressure of water to grade. The bottom design is permitted to include methods to anchor the bottom to a concrete base or other external structure to provide the required resistance to external pressure.

5.7 *Bench and Invert*—Bench and invert are permitted to be produced from glass fiber-reinforced thermosetting resin or other material suitable for the contents of the manhole. The bench and invert are permitted to include one or more 1/2-in. diameter ports to allow the equalization of pressure between the manhole interior and the cavity under the bench and invert. Use of larger ports is permitted to allow the field installation of concrete or grout in the cavity under the bench and invert.

**6. Requirements**

6.1 *Workmanship:*

6.1.1 *Exterior Surface*—The exterior surface shall be relatively smooth with no sharp projections. Hand-work finish is acceptable if enough resin is present to saturate all fibers. The exterior surface shall be free of blisters larger than 0.5 in. (12.7 mm) in diameter and delamination. Fibers loosely attached (can be removed with wire brush) are allowed if not excessive.

6.1.2 *Exterior Paint or Pigmentation*—Use of exterior paints, coatings, pigments and colorants is permitted when agreed upon between fabricator and purchaser. See Note 2.

6.1.3 *Interior Surface*—The interior surface shall be resin rich with no exposed fibers. The surface shall be free of crazing, delamination, blisters larger than 0.5 in. (12.7 mm) in diameter, and wrinkles of 0.125 in. (3.2 mm) or greater in depth. Surface pits shall be permitted up to 6/ft<sup>2</sup> (60/m<sup>2</sup>) if they are less than 0.75 in. (19 mm) in diameter and less than 0.0625 in. (1.6 mm) deep. Voids that cannot be broken with finger pressure and that are entirely below the resin surface shall be permitted up to 4/ft<sup>2</sup> (40/m<sup>2</sup>) if they are less than 0.5 in. (12.7 mm) in diameter.

6.1.4 *Interior Paint or Pigmentation*—Use of interior paints, coatings, pigments, and colorants are permitted when agreed upon between fabricator and purchaser. See Note 2.

6.1.5 *Indentations*—Indentations or other shape imperfections that will not affect performance are allowed.

6.2 *Repairs*—Any manhole or wetwell is permitted to be repaired to meet all requirements of this specification.

6.3 *Dimensions*—The dimensions shall be as shown below when measured in accordance with 8.3.1.

6.3.1 Minimum cylinder internal diameter of the manhole or wetwell shall be 42 in. (1057 mm). The minimum manway reducer inside diameter shall be 21 in. (533 mm).

6.3.2 Manhole or wetwell lengths shall be in 6-in. (152-mm) increments ±2 in. (51 mm).

6.3.3 Nominal inside diameters shall be 42 in. (1067 mm), 48 in. (1219 mm), 54 in. (1372 mm), 60 in. (1524 mm), 66 in. (1676 mm), and 72 in. (1829 mm). Tolerance on the inside diameter shall be ±1 %. Other diameters are allowed and are covered by this specification.

6.4 *Manhole Performance Test*—One complete manhole manufactured in a manner consistent in every way with this specification shall meet the performance criteria in 6.4.1 – 6.4.3. If a change in materials or methods of manufacturing is made and that change may affect the results of these tests, then the testing shall be repeated. These tests are to be conducted on a representative manhole to qualify the finished product characteristics. They are not considered to be a quality control procedure and are not required for production parts.

6.4.1 *Load Rating*—The complete manhole shall have a minimum dynamic-load rating of 16 000 lbf (71 172 N) when tested in accordance with 8.4. To establish this rating, the complete manhole shall not leak, crack, or suffer other damage when load tested to 40 000 lbf (177 929 N) and shall not deflect vertically downward more than 0.25 in. (6.35 mm) at the point of load application when loaded to 24 000 lb (106 757 N).

6.4.2 *Stiffness*—The manhole cylinder shall have the minimum pipe-stiffness values shown in Table 1 when tested in accordance with 8.5. It is permitted to interpolate stiffness requirements for other manhole lengths between the values in Table 1.

6.4.3 *Soundness*—The manholes shall not leak when tested in accordance with 8.6.

6.5 *Wetwell Stiffness*—The wetwell cylinder shall have the minimum pipe-stiffness value shown in Table 1 when tested in accordance with 8.5. It is permitted to interpolate stiffness requirements for other wetwell lengths between the values in Table 1. These tests are to be conducted on a representative wetwell to qualify the finished product characteristics. They are not considered to be a quality control procedure and are not required for production parts.

NOTE 3—Table 1 values are based upon a surrounding soil modulus of 750 psi or greater.

6.6 *Chemical Resistance*—Manhole or wetwell samples manufactured in a manner consistent in every way with this specification shall be tested in accordance with 8.7. The log of percent retention of each property after immersion testing when plotted against the log of immersion time, and extrapolated to 100 000 h shall assure retention of at least 50 % of initial properties. If a change is made in the manhole construction and that change may affect the results of the chemical resistance testing, then the testing shall be repeated. Chemical testing is conducted to determine the applicability of the materials used in the manufacture of the manhole to the specified use conditions. It is not considered to be a quality control procedure.

**TABLE 1 Stiffness Requirements**

Manhole or Wetwell Length, ft (mm)	F/ΔY, psi (kPa)
6 (1829)	0.72 (4.96)
12 (3658)	1.26 (8.69)
20 (6096)	2.01 (13.86)
25 (7620)	3.02 (20.82)
35 (10668)	5.24 (36.13)
50 (15240)	8.42 (58.81)

6.7 *Material Properties*—The following properties shall be established for each type of construction used in the manhole or wetwell. If a change in materials or methods of manufacturing is made and that change may affect the results of the following tests, then the testing shall be repeated. Material properties tests are conducted to qualify the finished product characteristics. They are not considered to be a quality control procedure and are not required for production parts.

6.7.1 *Material Composition*—The material composition of the manhole or wetwell in percent by weight shall be determined in accordance with 8.8.1.

6.7.2 *Compressive Strength*—The compressive strength in the hoop and axial directions of the manhole or wetwell shall be determined in accordance with 8.8.2.

6.7.3 *Flexural Strength and Modulus*—The flexural strength and flexural modulus of elasticity, in the hoop and axial directions of the manhole or wetwell, shall be determined in accordance with 8.8.3. Where component geometry will adversely affect the test results (an example would be flexural testing on curved samples taken in the hoop direction), hand fabricated samples made consistent with the materials and construction of the manhole or wetwell are permitted for testing.

6.8 *Hardness*—The surface hardness of the manhole or wetwell shall be determined in accordance with 8.8.4.

6.9 *Thickness*—The thickness of each manhole or wetwell component part shall be determined in accordance with 8.3.2.

6.10 *Field Vacuum Test Capability*—Each manhole or wetwell shall be designed to be structurally capable of withstanding a field applied test vacuum of -5 psi (-34 kPa) gauge after installation and backfilling. This design requirement is not to imply that a field vacuum test must be performed.

7. Quality Control

7.1 *Examination*—Each manhole or wetwell component part shall be examined for workmanship dimensions, hardness, and thickness in accordance with Section 6.

7.2 *Composition Control*—Controls on glass and resin content shall be maintained for all manhole or wetwell manufacturing processes. Records shall be maintained as needed to ensure products meet the requirements of the specification. Proper glass content by glass usage checks, by periodic glass and resin application rate checks, or by periodic material composition testing in accordance with 8.8.1 is permitted.

8. Test Methods

8.1 *Conditioning*—Specimens tested shall be representative of the actual manufacturing process. Conditioning of the specimens is not allowed unless specified by this specification.

8.2 *Test Conditions*—Conduct at ambient temperature without any special controls on temperature unless otherwise specified.

8.3 Dimensions:

8.3.1 Measure dimensions other than thickness with a steel tape with graduations of 0.125 in. (3 mm) or less.

8.3.2 *Thickness*—Measure to the nearest 0.01 in. (0.25 mm) with a micrometer, caliper, gauge, or other suitable instrument.

Make a minimum of one thickness reading per 34 ft<sup>2</sup> (3 m<sup>2</sup>) of surface in areas of constant thickness. Through regions of wall taper, make sufficient checks to establish the actual thickness.

8.4 Load Rating:

8.4.1 *Load Test*—The manhole tested shall be long enough to include at least one of all unique or repetitive features of the cylinder wall such as: bonded joints, adhesive seams, gasketed joints, etc., except for reducers and cylinder sections of a different diameter than the manhole. In any case, the minimum length of the manhole cylinder shall not be less than 36 in. (914 mm) for each cylinder diameter.

8.4.1.1 *Concentric Manholes*—The manhole to be tested shall be complete with cover and supporting ring installed. Apply the specified load eccentrically (see Fig. 2 for typical test model) on a 6 in. by 6 in. by 1/2 in. (152 mm by 152 mm by 12.7 mm) steel plate resting on the manhole cover. Locate the steel loading plate so that the center of the plate is within 4 in. (102 mm) from the edge of the cover. Load in 2000-lbf (8896-N) increments with close inspection between increases. Maintain the specified load for not less than 15 min.

8.4.1.2 *Eccentric Manholes*—The manhole to be tested shall be complete with cover and supporting ring installed. Apply the specified load eccentrically (see Fig. 3 for typical test model) 6 in. by 6 in. by 1/2 in. (152 mm by 152 mm by 12.7 mm) steel plate resting on the manhole cover. Locate the steel loading plate so that the center of the plate is within 4 in. (102 mm) from the edge of the cover at a point where the edge of the cover is nearest to the axis of the manhole cylinder. Load in 2000-lbf (8896-N) increments with close inspection between increases. Maintain the specified load for not less than 15 min.

8.4.2 *Deflection Test*—When load tested according to the procedure as outlined in 8.4.1.1 and 8.4.1.2 the top of the manhole(s) shall not deflect vertically downward more than

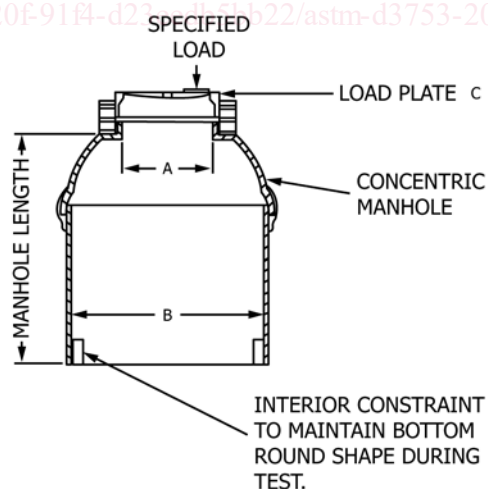

Table of Dimensions

	in.	(mm)
A	21 min	(533 min)
B	42 min	(1067 min)
C	6 by 6 by 1/2	(152 by 152 by 12.7)

FIG. 2 Concentric Manhole Load Test Model