



Designation: F3083/F3083M – 20a

Standard Specification for Emergency Conditions, Occupant Safety and Accommodations¹

This standard is issued under the fixed designation F3083/F3083M; the number immediately following the designation indicates the year of original adoption or, in the case of revision, the year of last revision. A number in parentheses indicates the year of last reapproval. A superscript epsilon (ϵ) indicates an editorial change since the last revision or reapproval.

1. Scope

1.1 This specification addresses emergency conditions, occupant safety and accommodations for occupants and cargo.

1.2 The applicant for a design approval must seek the individual guidance of their respective civil aviation authority (CAA) body concerning the use of this standard as part of a certification plan. For information on which CAA regulatory bodies have accepted this standard (in whole or in part) as a means of compliance to their airworthiness regulations (Hereinafter referred to as “the Rules”), refer to ASTM F44 webpage (www.ASTM.org/COMITTEE/F44.htm) which includes CAA website links.

1.3 The values stated in either SI units or inch-pound units are to be regarded separately as standard. The values stated in each system are not necessarily exact equivalents; therefore, to ensure conformance with the standard, each system shall be used independently of the other, and values from the two systems shall not be combined.

1.4 *This standard does not purport to address all of the safety concerns, if any, associated with its use. It is the responsibility of the user of this standard to establish appropriate safety, health, and environmental practices and determine the applicability of regulatory limitations prior to use.*

1.5 *This international standard was developed in accordance with internationally recognized principles on standardization established in the Decision on Principles for the Development of International Standards, Guides and Recommendations issued by the World Trade Organization Technical Barriers to Trade (TBT) Committee.*

2. Referenced Documents

- 2.1 *ASTM Standards*:²
[F3060 Terminology for Aircraft](#)

¹ This specification is under the jurisdiction of ASTM Committee F44 on General Aviation Aircraft and is the direct responsibility of Subcommittee F44.30 on Structures.

Current edition approved Oct. 15, 2020. Published November 2020. Originally approved in 2015. Last previous edition approved in 2020 as F3083/F3083M–20. DOI: 10.1520/F3083_F3083M-20A.

² For referenced ASTM standards, visit the ASTM website, www.astm.org, or contact ASTM Customer Service at service@astm.org. For *Annual Book of ASTM Standards* volume information, refer to the standard's Document Summary page on the ASTM website.

[F3061/F3061M Specification for Systems and Equipment in Small Aircraft](#)

[F3179/F3179M Specification for Performance of Aircraft](#)

2.2 *U.S. Code of Federal Regulations*:³

[49 CFR Part 572 Anthropomorphic Test Devices \(Subpart B\)](#)

2.3 *European Aviation Safety Agency Regulations*:⁴

[CS-23 Certification Specifications for Normal, Utility, Aerobatic, and Commuter Category Aeroplanes \(Amendment 3\)](#)

[CS-VLA Certifications Specifications for Very Light Aeroplanes \(Amendment 1\)](#)

2.4 *Other Standards*:

[DOT/FAA/AR-00 Aircraft Materials Fire Test Handbook](#)⁵

[PH1.25 Standard Specifications for Safety Photographic Film](#)⁶

3. Terminology

3.1 See Terminology [F3060](#) for definitions of terms used in this standard.

3.2 *Abbreviations*:

3.2.1 g_p —peak deceleration for seat/restraint system test

3.2.2 *HIC*—head injury criteria

3.2.3 t_r —rise time to the peak deceleration, g_p

4. Emergency Landing Conditions

4.1 *General*:

4.1.1 The airplane, although it may be damaged in emergency landing conditions, must be designed as prescribed in this section to protect each occupant under those conditions.

4.1.2 The structure must be designed to give each occupant every reasonable chance of escaping serious injury when:

4.1.2.1 Proper use is made of the seats, safety belts, and shoulder harnesses provided for in the design.

³ Available from U.S. Government Publishing Office (GPO), 732 N. Capitol Street NW, Washington, D.C. 20401, <http://www.ecfr.gov>.

⁴ Available from the European Aviation Safety Agency (EASA), Postfach 10 12 53, D-50452 Cologne, Germany, <https://www.easa.europa.eu/>.

⁵ Available from Federal Aviation Administration (FAA), 800 Independence Ave., SW, Washington, DC 20591, <http://www.faa.gov>.

⁶ Available from American National Standards Institute (ANSI), 25 W. 43rd St., 4th Floor, New York, NY 10036, <http://www.ansi.org>.

4.1.2.2 The occupant experiences the static inertia loads corresponding to the following ultimate load factors:

- (1) Upward, 3.0 g, or 4.5 g for airplanes approved for aerobatics;
- (2) Forward, 9.0 g;
- (3) Sideward, 1.5 g; and
- (4) Downward, 6.0 g when certification to the emergency exit provisions of 5.6.4.1(2) is requested.

4.1.2.3 The items of mass within the cabin, that could injure an occupant, experience the static inertia loads corresponding to the following ultimate load factors:

- (1) For Level 1 aircraft with a V_{S0} not more than 83 km/h [45 kts]:
 - (a) Upward, 3.0 g;
 - (b) Forward, 9.0 g; and
 - (c) Sideward, 1.5 g.
- (2) For all other aircraft:
 - (a) Upward, 3.0 g;
 - (b) Forward, 18.0 g; and
 - (c) Sideward, 4.5 g.

4.1.3 Each airplane with retractable landing gear must be designed to protect each occupant in a landing:

- 4.1.3.1 With the wheels retracted;
- 4.1.3.2 With moderate descent velocity; and
- 4.1.3.3 Assuming, in the absence of a more rational analysis:
 - (1) A downward ultimate inertia force of 3 g; and
 - (2) A coefficient of friction of 0.5 at the ground.

4.1.4 Unless it is established that a turnover is unlikely during an emergency landing, the structure must be designed to protect the occupants in a complete turnover. For determining the loads to be applied to the inverted airplane after a turnover, in the absence of a more rational analysis, an upward ultimate inertia load factor of 3.0 g and a coefficient of friction with the ground of 0.5 must be used.

4.1.4.1 For Level 1 aircraft, it must be assumed that turnover is likely.

4.1.4.2 For Level 2 through 4 aircraft, the likelihood of a turnover may be shown by an analysis assuming the following conditions:

- (1) The most adverse combination of weight and center of gravity position;
- (2) Longitudinal load factor of 9.0 g;
- (3) Vertical load factor of 1.0 g; and
- (4) For airplanes with tricycle landing gear, the nose wheel strut failed with the nose contacting the ground.

4.1.5 Except as provided in 5.5.1.4, the supporting structure must be designed to restrain, under loads up to those specified in 4.1.2.3, each item of mass that could injure an occupant if it came loose in a minor crash landing.

4.1.6 Powerplant and ESS mounts and supporting structures must withstand 15.0 g forward for powerplants and ESS installed behind and above the seating compartment.

4.1.7 For powerplants and ESS mounted inside the fuselage, aft of the cabin, it must be shown by test or analysis that the powerplants and ESS, the attached accessories, and the associated mounting structure:

4.1.7.1 Can withstand a forward acting static ultimate inertia load factor of 18.0 g plus the maximum takeoff engine thrust; or

4.1.7.2 The airplane structure is designed to preclude the powerplant or ESS and its attached accessories from entering or protruding into the cabin should the mounting structure fail.

4.2 Dynamic Conditions:

4.2.1 Each seat/restraint system must be designed to protect each occupant during an emergency landing when:

4.2.1.1 Proper use is made of seats, safety belts, and shoulder harnesses provided for in the design; and

4.2.1.2 The occupant is exposed to the loads resulting from the conditions prescribed in this section.

4.2.2 Except for those seat/restraint systems that are required to meet 4.2.4, 4.2.5, or 4.2.6, each seat/restraint system for crew or passenger occupancy during takeoff and landing, must successfully complete dynamic tests, or be demonstrated by rational analysis supported by dynamic tests, in accordance with each of the following conditions. These tests must be conducted with an occupant simulated by an anthropomorphic test device (ATD) defined by 49 CFR part 572, subpart B, or an approved equivalent, with a nominal weight of 77 kg [170 lb] and seated in the normal upright position.

4.2.2.1 For the first test, the change in velocity must not be less than 9.4 m/s [31 ft/s]. The seat/restraint system must be oriented in its nominal position with respect to the airplane and with the horizontal plane of the airplane pitched up 60°, with no yaw, relative to the impact vector. For seat/restraint systems to be installed in the first row of the airplane, peak deceleration must occur in not more than 0.05 s after impact and must reach a minimum of 19 g. For all other seat/restraint systems, peak deceleration must occur in not more than 0.06 s after impact and must reach a minimum of 15 g.

4.2.2.2 For the second test, the change in velocity must not be less than 12.8 m/s [42 ft/s]. The seat/restraint system must be oriented in its nominal position with respect to the airplane and with the vertical plane of the airplane yawed 10°, with no pitch, relative to the impact vector in a direction that results in the greatest load on the shoulder harness. For seat/restraint systems to be installed in the first row of the airplane, peak deceleration must occur in not more than 0.05 s after impact and must reach a minimum of 26 g. For all other seat/restraint systems, peak deceleration must occur in not more than 0.06 s after impact and must reach a minimum of 21 g.

4.2.2.3 To account for floor warpage, the floor rails or attachment devices used to attach the seat/restraint system to the airframe structure must be preloaded to misalign with respect to each other by at least 10° vertically (that is, pitch out of parallel) and one of the rails or attachment devices must be preloaded to misalign by 10° in roll prior to conducting the test defined by 4.2.2.2.

4.2.3 Compliance with the following requirements must be shown during the dynamic tests conducted in accordance with 4.2.2:

4.2.3.1 The seat/restraint system must restrain the ATD although seat/restraint system components may experience deformation, elongation, displacement, or crushing intended as part of the design.

4.2.3.2 The attachment between the seat/restraint system and the test fixture must remain intact, although the seat structure may have deformed.

4.2.3.3 Each shoulder harness strap must remain on the ATD's shoulder during the impact.

4.2.3.4 The safety belt must remain on the ATD's pelvis during the impact.

4.2.3.5 The results of the dynamic tests must show that the occupant is protected from serious head injury.

(1) When contact with adjacent seats, structure, or other items in the cabin can occur, protection must be provided so that the head impact does not exceed a head injury criteria (HIC) of 1000.

(2) The value of HIC is defined as:

$$HIC = \left\{ (t_2 - t_1) \left[\frac{1}{(t_2 - t_1)} \int_{t_1}^{t_2} a(t) dt \right]^{2.5} \right\}_{Max} \quad (1)$$

where:

t_1 = the initial integration time, expressed in seconds;
 t_2 = the final integration time, expressed in seconds; and
 $a(t)$ = the total acceleration vs. time curve for the head strike expressed as a multiple of g (units of gravity).

(3) Compliance with the HIC limit must be demonstrated by measuring the head impact during dynamic testing as prescribed in 4.2.2.1 and 4.2.2.2 or by a separate showing of compliance with the head injury criteria using test or analysis procedures.

4.2.3.6 Loads in individual shoulder harness straps must not exceed 7784 N [1750 lb_f]. If dual straps are used for retaining the upper torso, the total strap loads must not exceed 8896 N [2000 lb_f].

4.2.3.7 The compression load measured between the pelvis and the lumbar spine of the ATD must not exceed 6672 N [1500 lb_f].

4.2.4 For all single-engine airplanes with a V_{S0} of more than 113 km/h [61 kts] at maximum weight, and those multiengine airplanes with a V_{S0} of more than 113 km/h [61 kts] at maximum weight that do not comply with the Level 1 and Level 2 low-speed partial loss of thrust climb gradient specified in Specification F3179/F3179M.

4.2.4.1 The ultimate load factors of 4.1.2 must be increased by multiplying the load factors by the square of the ratio of the increased stall speed to 113 km/h [61 kts]. The increased ultimate load factors need not exceed the values reached at a V_{S0} of 146 km/h [79 kts]. The upward ultimate load factor for aircraft approved for aerobatics need not exceed 5.0 g .

4.2.4.2 The seat/restraint system test required by 4.2.2.1 of this section must be conducted in accordance with the following criteria:

(1) The change in velocity must not be less than 9.4 m/s [31 ft/s].

(2) The peak deceleration (g_p) of 19 g and 15 g must be increased and multiplied by the square of the ratio of the increased stall speed to $V_{normalize} = 113$ km/h [61 kts]:

$$g_p = 19.0 (V_{S0} / V_{normalize})^2 \quad \text{or} \quad g_p = 15.0 (V_{S0} / V_{normalize})^2 \quad (2)$$

(a) The peak deceleration need not exceed the value reached at a V_{S0} of 146 km/h [79 kts].

(3) The peak deceleration must occur in not more than time (t_r), which must be computed as follows:

$$t_r = \frac{31}{32.2(g_p)} = \frac{0.96}{g_p} \quad (3)$$

where:

g_p = the peak deceleration calculated in accordance with 4.2.4.2(2); and

t_r = the rise time (in seconds) to the peak deceleration.

4.2.5 For Level 1 aircraft with a maximum takeoff weight of not more than 750 kg [1653 lb] and a stalling speed in the landing configuration of not more than 83 km/h [45 kts], the requirements of 4.2.2, 4.2.3, and 4.2.6 are not required if the following conditions are met:

4.2.5.1 Each seat and its supporting structure must be designed for occupants weighing at least 86 kg [190 lb], and for the maximum load factors corresponding to the specified flight and ground load conditions, including the emergency landing conditions prescribed in 4.1.2.2.

4.2.5.2 Each occupant must be protected from serious head injury by a safety belt and shoulder harness when the occupant experiences the inertia forces prescribed in 4.1.2.2. (For reference, see Appendix X1.)

4.2.6 For Level 1 or Level 2 aeroplanes with a stalling speed in the landing configuration of not more than 113 km/h [61 kt], the requirements of 4.2.2, 4.2.3, and 4.2.5 are not required if the following conditions are met:

4.2.6.1 Each seat and its supporting structure must be designed for occupants weighing at least 86 kg [190 lb], and for the maximum load factors corresponding to the specified flight and ground load conditions, including the following, separately applied, conditions:

(1) Static inertia loads corresponding to the following ultimate load factors:

- (a) Upward, 3.0 g ;
- (b) Forward, 18.0 g ;
- (c) Sideward, ± 4.5 g ; and
- (d) Downward, 6.0 g .

4.2.6.2 If the seat is not integral to the airframe structure, the seat and seat attachment devices must be designed to accommodate floor warpage with no detachment or structural failures at the ultimate loading in 4.2.6.1. The floor rails or attachment devices used to attach the seat/restraint system to the airframe structure must accommodate a preload due to misalignment with respect to each other by at least 10° vertically (that is, pitch out of parallel) and one of the rails or attachment devices preloaded to misalign by 10° in roll.

4.2.6.3 Each occupant must be protected from serious injury, including serious head injury, when the occupant experiences the inertia forces prescribed in 4.2.6.1(1).

(1) The restraint system must be attached to the airframe and include a pelvic restraint and dual shoulder belts with a single-point release.

(2) The seat and restraint system must be designed to mitigate submarining of the occupant under emergency landing conditions.

(3) Aft-facing seats must have a head rest.

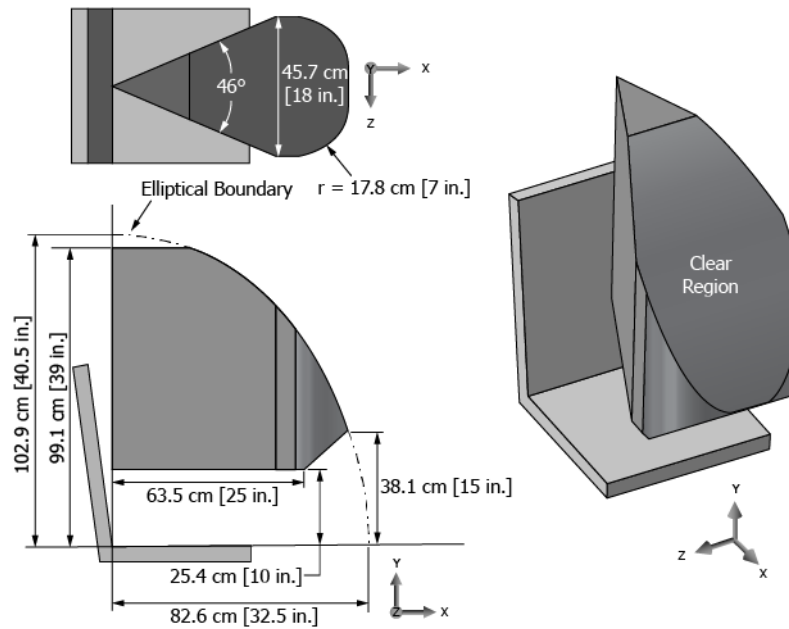

FIG. 1 Dimensions of Clear Region for Each Occupant

(4) With the seat positioned in the aft-most location intended for use during flight, no aircraft component (other than harnesses and other portions of the restraint system) or occupant can be present within the clear region highlighted in Fig. 1, defined from the seat reference point at the intersection of the compressed seat cushion and the tangent to the seat back and centered laterally on the seat.

(a) For purposes of this evaluation, the control yoke or stick can be assumed to be at its forwardmost position.

(5) Active restraints may be used for compliance in meeting submarining, head injury, and clear region criteria.

4.2.6.4 Occupant seats and the surrounding structure must be designed to attenuate vertical forces on the occupant in a manner acceptable to the governing CAA.

4.2.6.5 The forward fuselage structure must be designed to incorporate anti-plowing/anti-scooping features.

4.2.6.6 The cabin must be designed to maintain structural integrity when subjected to a load acting rearwards and upwards at an angle of 30° to the longitudinal axis of the aircraft and sideward at an angle of 10°. The load must be applied on the forward portion of the fuselage at a suitable point not behind the rudder pedals. The ultimate load applied shall be 12 times the maximum takeoff weight of the aeroplane less the weight of any structure or components forward of the load application.

(1) For purposes of this requirement, localized failure may occur, but the ability of the overall structure to maintain this load must be retained.

4.2.6.7 For compliance with the requirements for 4.1.4, it must be assumed that turnover is likely.

4.2.7 An alternate approach that achieves an equivalent, or greater, level of occupant protection to that required by this section may be used if substantiated on a rational basis.

5. Occupant and Cargo Accommodations

5.1 Seats, Berths, Litters, Safety Belts, and Shoulder Harnesses:

5.1.1 There must be a seat or berth for each occupant that meets the following:

5.1.1.1 Each seat/restraint system and the supporting structure must be designed to support occupants weighing at least 98 kg [215 lb] when subjected to the maximum load factors corresponding to the specified flight and ground load conditions, as defined in the approved operating envelope of the airplane. In addition, these loads must be multiplied by a factor of 1.33 in determining the strength of all fittings and the attachment of:

(1) Each seat to the structure; and

(2) Each safety belt and shoulder harness to the seat or structure.

5.1.1.2 Each forward-facing or aft-facing seat/restraint system in Level 1 through 3 airplanes must consist of a seat, a safety belt, and a shoulder harness, with a metal-to-metal latching device, that are designed to provide the occupant protection provisions required in 4.2. Other seat orientations must provide the same level of occupant protection as a forward-facing or aft-facing seat with a safety belt and a shoulder harness, and must provide the protection provisions of 4.2.

5.1.1.3 For Level 4 airplanes, each seat and the supporting structure must be designed for occupants weighing at least 77 kg [170 lb] when subjected to the inertia loads resulting from the ultimate static load factors prescribed in 4.1.2.2. Each occupant must be protected from serious head injury when subjected to the inertia loads resulting from these load factors by a safety belt and shoulder harness, with a metal-to-metal latching device, for the front seats and a safety belt, or a safety

belt and shoulder harness, with a metal-to-metal latching device, for each seat other than the front seats.

5.1.1.4 Each restraint system must have a single-point release for occupant evacuation.

5.1.1.5 The restraint system for each crewmember must allow the crewmember, when seated with the safety belt and shoulder harness fastened, to perform all functions necessary for flight operations.

5.1.1.6 Each pilot seat must be designed for the reactions resulting from the application of pilot forces to the primary flight controls.

5.1.1.7 There must be a means to secure each safety belt and shoulder harness, when not in use, to prevent interference with the operation of the airplane and with rapid occupant egress in an emergency.

5.1.1.8 Unless otherwise placarded, each seat in an airplane approved for bank angles greater than 60°, spins or aerobatics must be designed to accommodate an occupant wearing a parachute.

5.1.1.9 The cabin area surrounding each seat, including the structure, interior walls, instrument panel, control wheel, pedals, and seats within striking distance of the occupant's head or torso (with the restraint system fastened) must be free of potentially injurious objects, sharp edges, protuberances, and hard surfaces. If energy absorbing designs or devices are used to meet this requirement, they must protect the occupant from serious injury when the occupant is subjected to the inertia loads resulting from the ultimate static load factors prescribed in 4.1.2.2, or they must comply with the occupant protection provisions of 4.2, as required in 5.1.1.2 and 5.1.1.3.

5.1.1.10 Each seat track must be fitted with stops to prevent the seat from sliding off the track.

5.1.1.11 Each seat/restraint system may use design features, such as crushing or separation of certain components, to reduce occupant loads when showing compliance with the requirements of 4.2; otherwise, the system must remain intact.

5.1.1.12 For the purposes of this section, a front seat is a seat located at a flight crewmember station or any seat located alongside such a seat.

5.1.1.13 Each berth, or provisions for a litter, installed parallel to the longitudinal axis of the airplane, must be designed so that the forward part has a padded end-board, canvas diaphragm, or equivalent means that can withstand the load reactions from a 98 kg [215 lb] occupant when subjected to the inertia loads resulting from the ultimate static load factors of 4.1.2.2. In addition:

(1) Each berth or litter must have an occupant restraint system and may not have corners or other parts likely to cause serious injury to a person occupying it during emergency landing conditions; and

(2) Occupant restraint system attachments for the berth or litter must withstand the inertia loads resulting from the ultimate static load factors of 4.1.2.2.

5.1.1.14 Proof of compliance with the static strength requirements of this section for seats and berths approved as part of the type design and for seat and berth installations may be shown by:

(1) Structural analysis, if the structure conforms to conventional airplane types for which existing methods of analysis are known to be reliable;

(2) A combination of structural analysis and static load tests to limit load; or

(3) Static load tests to ultimate loads.

5.2 Doors:

5.2.1 Each closed cabin with passenger accommodations must have at least one adequate and easily accessible external door.

5.2.2 Passenger doors must not be located with respect to any propeller disk or any other potential hazard so as to endanger persons using the door.

5.2.3 In addition, for Level 4 airplanes, the following requirements apply:

5.2.3.1 Each passenger entry door must qualify as a floor level emergency exit. This exit must have a rectangular opening of not less than 0.61 m [2 ft] wide by 1.22 m [4 ft] high, with corner radii not greater than one-third the width of the exit.

5.2.3.2 If an integral stair is installed at a passenger entry door, the stair must be designed so that, when subjected to the inertia loads resulting from the ultimate static load factors in 4.1.2.2 and following the collapse of one or more legs of the landing gear, it will not reduce the effectiveness of emergency egress through the passenger entry door.

5.2.4 If lavatory doors are installed, they must be designed to preclude an occupant from becoming trapped inside the lavatory. If a locking mechanism is installed, it must be capable of being unlocked from outside of the lavatory.

5.3 Baggage and Cargo Compartments:

5.3.1 Each baggage and cargo compartment must:

5.3.1.1 Be designed for its placarded maximum weight of contents and for the critical load distributions at the appropriate maximum load factors corresponding to the specified flight and ground load conditions.

5.3.1.2 Have means to prevent the contents of any compartment from becoming a hazard by shifting, and to protect any controls, wiring, lines, equipment or accessories whose damage or failure would affect safe operations.

5.3.1.3 Have a means to protect occupants from injury by the contents of any compartment, located aft of the occupants and separated by structure, when the ultimate forward inertial load factor is 9 g and assuming the maximum allowed baggage or cargo weight for the compartment.

5.3.2 Designs that provide for baggage or cargo to be carried in the same compartment as passengers must have a means to protect the occupants from injury when the baggage or cargo is subjected to the inertial loads resulting from the ultimate static load factors of 4.1.2.3, assuming the maximum allowed baggage or cargo weight for the compartment.

5.3.2.1 For Level 1 aircraft with a V_{S0} not more than 83 km/h [45 kts], if there is no structure between baggage and occupant compartments the baggage items located behind the occupants and those which might become a hazard in a crash must be secured for 1.33×9 g.

5.4 Emergency Evacuation:

5.4.1 For Level 4 airplanes, an evacuation demonstration must be conducted utilizing the maximum number of occupants for which certification is desired. The demonstration must be conducted under simulated night conditions using only the emergency exits on the most critical side of the airplane. The participants must be representative of average passengers with no prior practice or rehearsal for the demonstration. Evacuation must be completed within 90 s.

5.4.2 In addition, when certification to the emergency exit provisions of 5.6.4.1(2) is requested, only the emergency lighting system required by 5.8 may be used to provide cabin interior illumination during the evacuation demonstration required in 5.4.1.

5.5 Flightcrew Emergency Exits:

5.5.1 For airplanes where the proximity of the passenger emergency exits to the flightcrew area does not offer a convenient and readily accessible means of evacuation for the flightcrew, the following apply:

5.5.1.1 There must be either one emergency exit on each side of the airplane, or a top hatch emergency exit, in the flightcrew area;

5.5.1.2 Each emergency exit must be located to allow rapid evacuation of the crew and have a size and shape of at least a 0.48 m [1.58 ft] by 0.51 m [1.67 ft] unobstructed rectangular opening; and

5.5.1.3 For each emergency exit that is not less than 1.83 m [6 ft] from the ground, an assisting means must be provided. The assisting means may be a rope or any other means demonstrated to be suitable for the purpose. If the assisting means is a rope, or an approved device equivalent to a rope, it must be:

(1) Attached to the fuselage structure at or above the top of the emergency exit opening or, for a device at a pilot's emergency exit window, at another approved location if the stowed device, or its attachment, would reduce the pilot's view; and

(2) Able (with its attachment) to withstand a 1779 N [400 lbf] static load.

5.5.1.4 For airplanes that are used only for the carriage of cargo, the flightcrew emergency exits must meet the requirements of 5.6 under any cargo loading conditions.

5.6 Emergency Exits:

5.6.1 *Number and Location*—Emergency exits must be located to allow escape without crowding in any normal or probable crash attitude. The airplane must have at least the following emergency exits:

5.6.1.1 For all airplanes with a seating capacity of two or more, excluding airplanes with canopies, at least one emergency exit on the opposite side of the cabin from the main door specified in 5.2.

5.6.1.2 If the pilot compartment is separated from the cabin by a door that is likely to block the pilot's escape in a minor crash, there must be an exit in the pilot's compartment. The number of exits required by 5.6.1.1 must then be separately determined for the passenger compartment, using the seating capacity of that compartment.

5.6.1.3 Emergency exits must not be located with respect to any propeller disk or any other potential hazard so as to endanger persons using that exit.

5.6.2 *Type and Operation*—Emergency exits must be movable windows, panels, canopies, or external doors, openable from both inside and outside the airplane, that provide a clear and unobstructed opening large enough to admit a 0.48 m [1.58 ft] by 0.66 m [2.17 ft] ellipse. Auxiliary locking devices used to secure the airplane must be designed to be overridden by the normal internal opening means. The inside handles of emergency exits that open outward must be adequately protected against inadvertent operation. In addition, each emergency exit must:

5.6.2.1 Be readily accessible, requiring no exceptional agility to be used in emergencies;

5.6.2.2 Have a method of opening that is simple and obvious;

5.6.2.3 Be arranged and marked for easy location and operation, even in darkness;

5.6.2.4 Have reasonable provisions against jamming by fuselage deformation;

5.6.2.5 In the case of airplanes approved for aerobatics, allow each occupant to abandon the airplane at any speed between V_{S0} and V_D ; and

5.6.2.6 In the case of airplanes approved for intentional spins only, allow each occupant to abandon the airplane at the highest speed likely to be achieved in the maneuver for which the airplane is certificated.

5.6.3 *Tests*—The proper functioning of each emergency exit must be shown by tests.

5.6.4 *Doors and Exits*—In addition, for Level 4 airplanes, the following requirements apply:

5.6.4.1 In addition to the passenger entry door, the requirements of either 5.6.4.1(1) or 5.6.4.1(2) must be met.

(1) There must be emergency exits, as defined in 5.6.2, in the following locations:

(a) For an airplane with a total passenger seating capacity of 15 or fewer, an emergency exit is required on each side of the cabin; and

(b) For an airplane with a total passenger seating capacity of 16 through 19, three emergency exits are required with one on the same side as the passenger entry door and two on the side opposite the door.

(2) There must be an emergency exit on the side of the cabin opposite the passenger entry door that:

(a) Has a rectangular opening measuring not less than 0.51 m [1.67 ft] by 0.91 m [3 ft] high, with corner radii not greater than one-third the width of the exit;

(b) Has a step up inside the airplane of not more than 0.51 m [1.67 ft];

(c) If the exit is located over the wing, the step down outside the airplane may not exceed 0.69 m [2.25 ft]; and

(d) The airplane complies with the additional requirements of 4.1.2.2(4), 5.4.2, 5.7.3, 5.8, 5.10.2, and 5.11.

5.6.4.2 A means must be provided to lock each emergency exit and to safeguard against its opening in flight, either inadvertently by persons or as a result of mechanical failure. In addition, a means for direct visual inspection of the locking

mechanism must be provided to determine that each emergency exit for which the initial opening movement is outward is fully locked.

5.6.4.3 Each required emergency exit, except floor level exits, must be located over the wing or, if not less than 1.8 m [6 ft] from the ground, must be provided with an acceptable means to assist the occupants to descend to the ground. Emergency exits must be distributed as uniformly as practical, taking into account passenger seating configuration.

5.6.5 For multiengine airplanes, ditching emergency exits must be provided in accordance with the following requirements, unless the emergency exits required by 5.6.1 or 5.6.4 already comply with them:

5.6.5.1 One exit above the waterline on each side of the airplane having the dimensions specified in 5.6.2 or 5.6.4, as applicable; and

5.6.5.2 If side exits cannot be above the waterline, there must be a readily accessible overhead hatch emergency exit that has a rectangular opening measuring not less than 0.51 m [1.67 ft] by 0.91 m [3 ft] long, with corner radii not greater than one-third the width of the exit.

5.6.5.3 In lieu of 5.6.5.2, if any side exit(s) cannot be above the waterline, a device may be placed at each of such exit(s) prior to ditching. This device must slow the inflow of water when such exit(s) is opened with the airplane ditched. For Level 4 airplanes, the clear opening of such exit(s) must meet the requirements defined in 5.6.4.

5.7 Emergency Exit Marking:

5.7.1 Each emergency exit and external door in the passenger compartment must be externally marked and readily identifiable from outside the airplane by:

5.7.1.1 A conspicuous visual identification scheme; and

5.7.1.2 A permanent decal or placard on or adjacent to the emergency exit which shows the means of opening the emergency exit, including any special instructions, if applicable.

5.7.2 In addition, for Level 4 airplanes, these exits and doors must be internally marked with the word “exit” by a sign which has white letters 25 mm [1 in.] high on a red background 51 mm [2 in.] high, be self-illuminated or independently, internally electrically illuminated, and have a minimum brightness of at least 0.51 cd/m² [160 microlamberts]. The color may be reversed if the passenger compartment illumination is essentially the same.

5.7.3 In addition, when certification to the emergency exit provisions of 5.6.4.1(2) is requested, the following apply:

5.7.3.1 Each emergency exit, its means of access, and its means of opening, must be conspicuously marked;

5.7.3.2 The identity and location of each emergency exit must be recognizable from a distance equal to the width of the cabin;

5.7.3.3 Means must be provided to assist occupants in locating the emergency exits in conditions of dense smoke;

5.7.3.4 The location of the operating handle and instructions for opening each emergency exit from inside the airplane must be shown by marking that is readable from a distance of 0.76 m [2.5 ft];

5.7.3.5 Each passenger entry door operating handle must:

(1) Be self-illuminated with an initial brightness of at least 0.51 cd/m² [160 microlamberts]; or

(2) Be conspicuously located and well illuminated by the emergency lighting even in conditions of occupant crowding at the door;

5.7.3.6 Each passenger entry door with a locking mechanism that is released by rotary motion of the handle must be marked:

(1) With a red arrow, with a shaft of at least 19 mm [0.75 in.] wide and a head twice the width of the shaft, extending along at least 70° of arc at a radius approximately equal to three-fourths of the handle length;

(2) So that the center line of the exit handle is within ±25 mm [1 in.] of the projected point of the arrow when the handle has reached full travel and has released the locking mechanism;

(3) With the word “open” in red letters, 25 mm [1 in.] high, placed horizontally near the head of the arrow; and

5.7.3.7 In addition to the requirements of 5.7.1, the external marking of each emergency exit must:

(1) Include a 51 mm [2 in.] color band outlining the exit; and

(2) Have a color contrast that is readily distinguishable from the surrounding fuselage surface. The contrast must be such that if the reflectance of the darker color is 15 % or less, the reflectance of the lighter color must be at least 45 %. “Reflectance” is the ratio of the luminous flux reflected by a body to the luminous flux it receives. When the reflectance of the darker color is greater than 15 %, at least a 30 % difference between its reflectance and the reflectance of the lighter color must be provided.

5.8 Emergency Lighting:

5.8.1 When certification to the emergency exit provisions of 5.6.4.1(2) is requested, the following apply:

5.8.1.1 An emergency lighting system, independent of the main cabin lighting system, must be installed. However, the source of general cabin illumination may be common to both the emergency and main lighting systems if the power supply to the emergency lighting system is independent of the power supply to the main lighting system.

5.8.1.2 There must be a crew warning indication in the cockpit when power is on in the airplane and the emergency lighting control device is not armed.

5.8.1.3 The emergency lights must be operable manually from the flightcrew station and be provided with automatic activation. The cockpit control device must have “on,” “off,” and “armed” positions so that, when armed in the cockpit, the lights will operate by automatic activation.

5.8.1.4 There must be a means to safeguard against inadvertent operation of the cockpit control device from the “armed” or “on” positions.

5.8.1.5 The cockpit control device must have provisions to allow the emergency lighting system to be armed or activated at any time that it may be needed.

5.8.1.6 When armed, the emergency lighting system must activate and remain lighted when:

(1) The normal electrical power of the airplane is lost; or