



# Standard Test Method for Measuring Force Reduction, Vertical Deformation, and Energy Restitution of Synthetic Turf Systems Using the Advanced Artificial Athlete<sup>1</sup>

This standard is issued under the fixed designation F3189; the number immediately following the designation indicates the year of original adoption or, in the case of revision, the year of last revision. A number in parentheses indicates the year of last reapproval. A superscript epsilon ( $\epsilon$ ) indicates an editorial change since the last revision or reapproval.

## 1. Scope

1.1 This test method specifies a method for measuring force reduction, vertical deformation, and energy restitution of synthetic turf surfaces.

1.2 This method is used to characterize properties of synthetic turf systems including the turf fabric, infill material, and shock pad (if applicable).

1.3 It can be used for characterizing synthetic turf systems in laboratory environment or in the field.

1.4 The values stated in SI units are to be regarded as standard. No other units of measurement are included in this standard.

1.5 *This standard does not purport to address all of the safety concerns, if any, associated with its use. It is the responsibility of the user of this standard to establish appropriate safety, health, and environmental practices and determine the applicability of regulatory limitations prior to use.*

1.6 *This international standard was developed in accordance with internationally recognized principles on standardization established in the Decision on Principles for the Development of International Standards, Guides and Recommendations issued by the World Trade Organization Technical Barriers to Trade (TBT) Committee.*

## 2. Referenced Documents

2.1 *ASTM Standards:*<sup>2</sup>

**E177 Practice for Use of the Terms Precision and Bias in ASTM Test Methods**

**E691 Practice for Conducting an Interlaboratory Study to Determine the Precision of a Test Method**

<sup>1</sup> This test method is under the jurisdiction of ASTM Committee F08 on Sports Equipment, Playing Surfaces, and Facilities and is the direct responsibility of Subcommittee F08.65 on Artificial Turf Surfaces and Systems.

Current edition approved Nov. 1, 2020. Published December 2020. Originally approved in 2017. Last previous edition approved in 2017 as F3189 – 17. DOI: 10.1520/F3189-20.

<sup>2</sup> For referenced ASTM standards, visit the ASTM website, [www.astm.org](http://www.astm.org), or contact ASTM Customer Service at [service@astm.org](mailto:service@astm.org). For *Annual Book of ASTM Standards* volume information, refer to the standard's Document Summary page on the ASTM website.

## 3. Terminology

3.1 *Definitions of Terms Specific to This Standard:*

3.1.1 *energy restitution (ER), n*—a measure of the energy returned by the synthetic turf surface after the impact force has been applied.

3.1.2 *energy restitution coefficient, n*—the ratio of the dynamic load energy applied to the surface to the energy returned by the surface.

3.1.3 *force reduction (FR), n*—the ability of a synthetic turf sports surface to reduce the impact force of a mass falling onto that surface.

3.1.3.1 *Discussion*—The reduction in impact force for this test method is expressed as a percentage reduction when compared to a reference force of 6760 N. The reference force is the theoretical maximum impact force that occurs when the test is performed on a rigid surface (concrete).

3.1.4 *synthetic turf system, n*—all components of the synthetic turf surface and subsurface that have the potential to influence the dynamic properties of the surface.

3.1.4.1 *Discussion*—These include any shock pads or dynamic base constructions installed as part of the synthetic turf system.

3.1.5 *vertical deformation (Def), n*—a measure of the distance a test foot penetrates into the surface when a standard impact force is applied.

3.2 *Symbols:*

3.2.1 *A*—acceleration in  $m/s^2$ .

3.2.2 *Def*—deformation in millimeters.

3.2.3 *E*—energy in Joules.

3.2.4 *ER*—energy restitution.

3.2.5 *F*—force in Newtons.

3.2.6 *FR*—force reduction in %.

3.2.7 *g*—acceleration due to gravity.

3.2.8 *R*—coefficient of restitution.

3.2.9 *t*—time in seconds.

#### 4. Summary of Test Method

4.1 A mass with a spring attached is allowed to fall onto the test surface. The acceleration of the mass is recorded from the moment of release until after its impact with the turf surface. Force Reduction is the percentage reduction in the measured maximum force ( $F_{max}$ ) relative to the reference force ( $F_{max}$ ).

4.2 Deformation is calculated by double integration of the record of acceleration versus time. Energy restitution is calculated from the force versus deformation curve.

#### 5. Significance and Use

5.1 The dynamic interaction between the athlete and the synthetic turf surface affects the comfort and the performance of the athlete. Interaction with a surface that has low amounts of deformation and shock absorption allows the player to run fast and turn quickly, but has the potential to cause discomfort and damage to the lower extremity joints. Synthetic turf surfaces having high deformation have lower energy restitution. Less of the energy exerted by the athlete returns from the surface, possibly increasing the fatigue for the performing athlete.

#### 6. Test Conditions

6.1 *Laboratory Test Conditions:*

6.1.1 Laboratory tests shall be conducted on samples of the complete turf system. The test sample shall have nominal dimensions of 1 m by 1 m. The turf samples shall be prepared in accordance with the manufacturers stated method.

6.1.2 *Characteristics of the Laboratory Floor*—The laboratory floor shall be concrete with a minimum thickness of 100 mm.

6.1.3 *Conditioning and Test Temperature*—The test piece shall be conditioned at laboratory temperature ( $23 \pm 2^\circ\text{C}$ ) for  $24 \pm 0.5$  h.

6.2 *Field Test Conditions*—Testing in the field shall be performed at ambient temperature and humidity which shall be recorded and reported.

#### 7. Test Apparatus

7.1 The principle of the test apparatus is shown in Fig. 1 and consists of the following essential components specified in 7.2 – 7.7.

7.2 Falling mass (3), incorporating a helical metal spring (5) and steel foot (6) and fitted with an accelerometer (4), having a total mass of  $20.0 \pm 0.1$  kg.

7.3 Helical steel spring (5), whose characteristic is linear (measured with maximum increments of 1000 N) with a spring rate of  $2000 \pm 60$  N/mm over the range of 0.1 to 7.5 kN. The

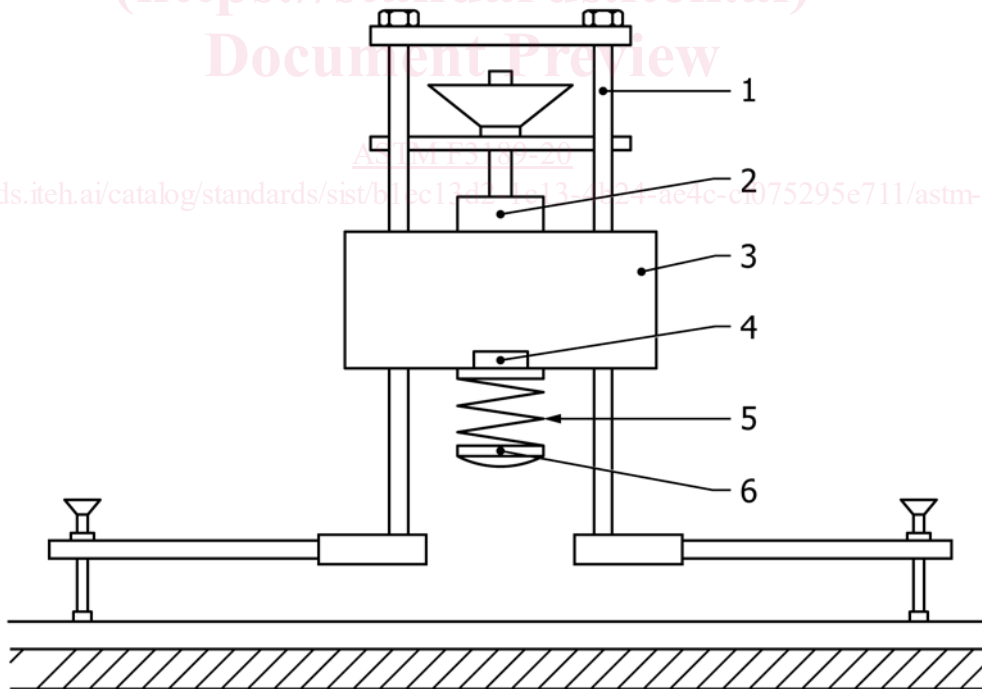

- Keys:
- 1 guide for the falling mass
  - 2 electric magnet
  - 3 falling mass
  - 4 accelerometer
  - 5 spring
  - 6 test foot

FIG. 1 Test Apparatus

axis of the spring shall be vertical and shall be directly below the center of gravity of the falling mass. The spring shall have three coaxial coils that shall be rigidly fixed together at their ends. The mass of the spring shall be  $0.80 \pm 0.05$  g.

7.4 Steel test foot (6) having a lower side rounded to a radius of  $500 \pm 50$  mm; an edge radius of 1 mm; a diameter of  $70 \pm 1$  mm and a minimum thickness of 10 mm. The mass of the test foot shall be  $400 \pm 50$  g.

7.5 Test frame with minimum of three adjustable supporting feet, no less than 250 mm from the point of application of the load. The design of the supporting feet shall insure the weight of the test apparatus is equally distributed on all of the feet.

7.5.1 The pressure (with the mass) on each foot shall be  $<0.020$  N/mm<sup>2</sup> and the pressure (without the mass) on each foot shall be  $>0.003$  N/mm<sup>2</sup>.

7.5.2 The complete system will have a mass of  $\leq 50$  kg.

7.6 A piezo-resistive accelerometer (4) with the following characteristics:

- (1) measuring range:  $\pm 50$  g;
- (2) 3 dB upper frequency response:  $\geq 1$  kHz;
- (3) linearity error  $< 2$  %.

7.6.1 The accelerometer shall be firmly attached to avoid natural filtering and the generation of spurious signals.

7.7 Means of supporting the mass (2) that allows the falling height to be set with an uncertainty of no greater than 0.25 mm.

7.8 Means of conditioning and recording the signal from the acceleration sensing device and a means of displaying the recorded signal (see Fig. 2).

7.8.1 Sampling rate minimum: 9600 Hz;

7.8.2 Electronic A-D converter with a resolution giving 1 bit equal to a maximum 0.005 g acceleration;

7.8.3 Signal from the acceleration sensing device shall be filtered with a 2nd order low-pass Butterworth filter with a cut-off frequency of 600 Hz.

7.9 Means of calculating the speed and displacement of the falling weight during the course of impact by integration and double integration of the acceleration signal. To be verified in accordance with 8.4 and 8.5.

### 8. Verification of Impact Speed

8.1 *General*—The verification is carried out to ensure the correct impact speed (or energy, because the mass is fixed) and the correct functioning of the apparatus. The checking procedure shall consist of three steps and shall be carried out on a stable and rigid floor (no significant deflection under a 5 kg/cm<sup>2</sup> pressure) as follows:

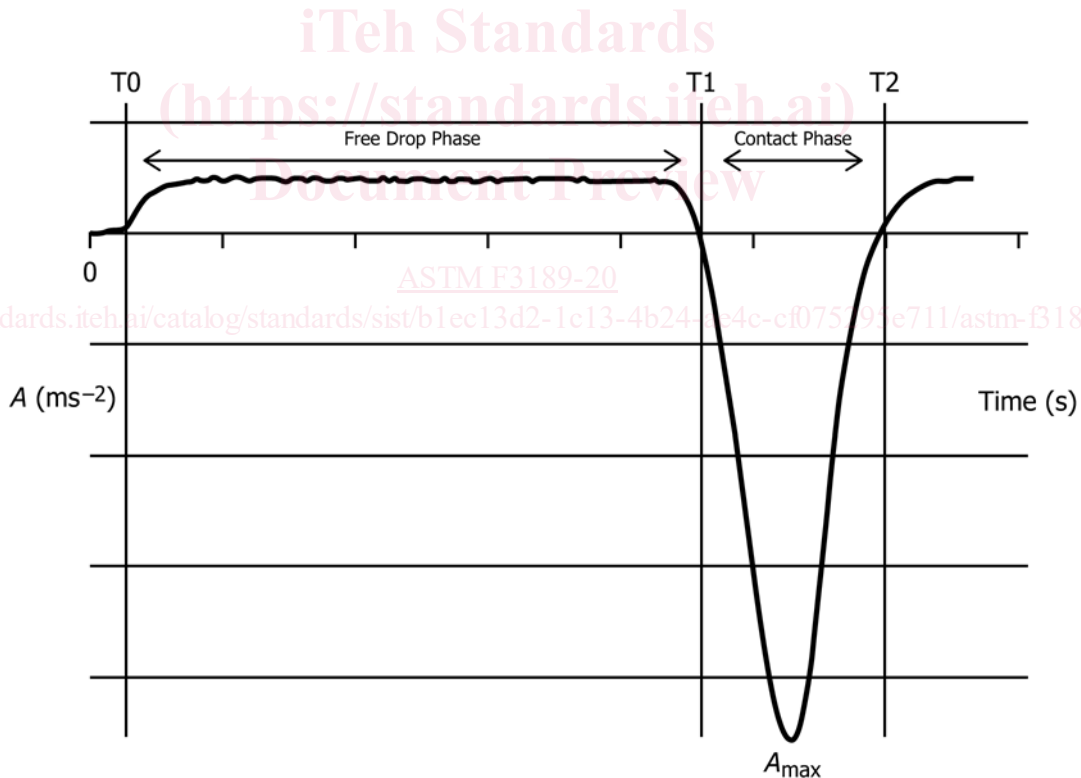

FIG. 2 Example of Falling Mass Acceleration Versus Time Curve

where:

$T_0$  = time when the mass starts to fall.

$T_1$  = time when the test foot makes initial contact with the surface (determined on the Velocity/time curve –  $V_{max}$ \*)

$T_2$  = time (determined on the Velocity/time curve –  $V_{min}$ \*) corresponding to the maximum velocity when the mass rebounds after the impact.

NOTE 1— $V_{min}$  can be a minimum or maximum value depending on the sensor's direction.

8.1.1 *Laboratory Testing*—At least once on any day on which testing is undertaken or following dismantling and re-assembly of the test apparatus, prior to carrying out any measurements

8.1.2 *Site Testing*—Following re-assembly of the test apparatus, prior to carrying out any measurements.

8.2 Set up the apparatus to ensure a free drop that is no more than  $\pm 1^\circ$  from the vertical. Adjust the height of the lower face of the steel test foot so it is  $55.00 \pm 0.25$  mm above the rigid floor. Drop the weight on the rigid floor and record the acceleration of the falling weight until the end of the impact.

8.3 Repeat 8.1 twice, giving a total of 3 impacts.

8.4 For each impact calculate, by integration from T0 to T1 of the acceleration signal, the initial impact velocity. Calculate the mean impact velocity of the three recordings. The mean impact velocity shall be in the range of 1.02 m/s and 1.04 m/s. If the initial impact velocity is outside the specified range, the test apparatus is not operating correctly and any subsequent results obtained shall be considered invalid.

8.5 After verifying the initial impact velocity, place the falling weight on the rigid floor. Measure the height between a static reference point on the apparatus (for example, the magnet) and the falling weight. The measured height shall be used for all measurements and is designated the “lift height”.

NOTE 1—The “lift height” will be slightly greater than 55.0 mm due to the deflection of the apparatus during operation.

## 9. Checking of Force on Concrete

9.1 At a frequency of at least once every 3 months check the force on the laboratory concrete floor to ensure the consistency of maximum force on concrete as measured by the apparatus and the theoretical force on concrete ( $6760 \text{ N} \pm 250 \text{ N}$ ).

## 10. Test Procedure

10.1 *General*—To avoid influence of the operator’s weight on the results, through variation in the preload on the sports surface system under test, the operator shall be positioned:

10.1.1 *Laboratory Test*—Off the sample.

10.1.2 *Field Test*—At least 1 m from the point of impact.

10.2 *Test Method:*

10.2.1 Set the apparatus so it is positioned vertically on the test sample.

10.2.2 Lower the test foot smoothly onto the surface of the test piece. Immediately after (within 10 s) set the “lift height” described in 8.5 and reattach the mass on the magnet.

10.2.3 After 30 ( $\pm 5$ ) s (to allow the test specimen to relax after removal of the test mass) drop the mass and record the acceleration signal.

10.2.4 Re-validate the lift height after the impact so that within  $30 \pm 5$  s the mass is lifted from the surface and re-attached to the magnet.

10.2.5 Repeat 10.2.4 and 10.2.5 to obtain a total of 3 impacts.

10.3 *Calculation of Force Reduction and Expression of Results:*

10.3.1 Calculate the maximum force ( $F_{max}$ ) at the impact with the following formula:

$$F_{max} = m \times (A_{max} + g) \quad (1)$$

where:

$F_{max}$  = peak force, expressed in Newtons (N);  
 $A_{max}$  = peak acceleration during the impact ( $\text{ms}^{-2}$ );  
 $m$  = calibrated mass of the falling weight (kg); and  
 $g$  = the acceleration due to gravity ( $\text{ms}^{-2}$ ).

10.3.2 Calculate the Force Reduction ( $FR$ ) with the following formula:

$$FR = \left[ 1 - \frac{F_{max}}{6760} \right] \times 100 \quad (2)$$

where:

$FR$  = force reduction, %, and  
 $F_{max}$  = peak force measured on the synthetic turf surface (N).

10.3.3 Report the value of Force Reduction as the mean of the second and third drops in the same location to the nearest 1 %, for example, 60 %.

10.4 *Calculation of Deformation and Expression of Results:*

10.4.1 Calculate by double integration of  $a(t)$  on the interval  $[T1, T2]$  the displacement of the weight  $D_{weight}(t)$ , starting at the moment where it has reached its highest velocity (at T1). (See Fig. 3.) The vertical deformation is defined (on the time interval  $[T1, T2]$ ) as:

$$VD = D_{weight} - D_{spring} \quad (3)$$

where:

$D_{weight} = \max \left[ \int_{T1}^{T2} \int_{T0}^{T2} A \quad dt \quad dt \right]$ , with  $D_{weight} = 0$  m at T1,  
 and

$$D_{spring} = \frac{(m \times A_{max})}{C_{spring}}$$

where:

$A_{max}$  = peak acceleration during the impact ( $9.81 \text{ ms}^{-2}$ ),  
 $m$  = the calibrated mass of the falling weight (kg), and  
 $C_{spring}$  = spring constant (given in the certificate of calibration and measured in the adapted range).

10.4.2 Report the value of Vertical Deformation as the mean of the second and third drops to the nearest 0.1 mm, for example, 6.6 mm.

10.5 *Calculation of Energy of Restitution and Expression of Results:*

10.5.1 Draw the curves  $F(t)$  and  $Def(t)$  using  $a(t)$ .

where:

$F(t)$  = measured force on the surface versus time;  
 $Def(t)$  = deformation of the surface versus time;  
 $a(t)$  = acceleration signal from the sensor versus time.

10.5.2 On the same time base, draw the curve  $F(Def)$  (see Fig. 4).

10.5.3 *Calculate:*

10.5.3.1 The impact energy by the formula:

$$E_i = \int_{Def0}^{Def_{max}} F(D e f) D e f \quad \text{initial condition } D e f_0 = 0 \text{ m} \quad (4)$$